

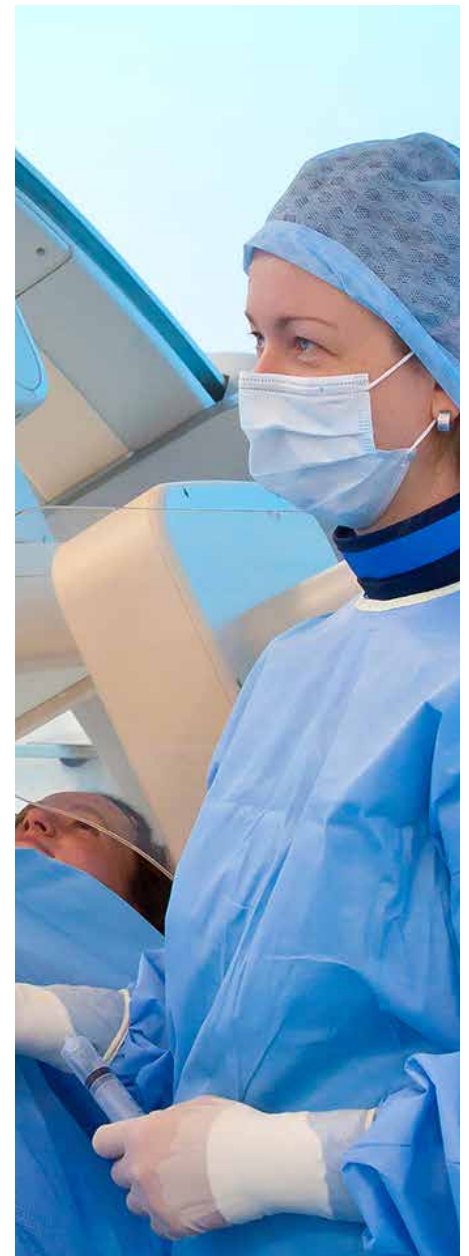

MEDIZINISCHE
UNIVERSITÄT
INNSBRUCK

Research Report 2016

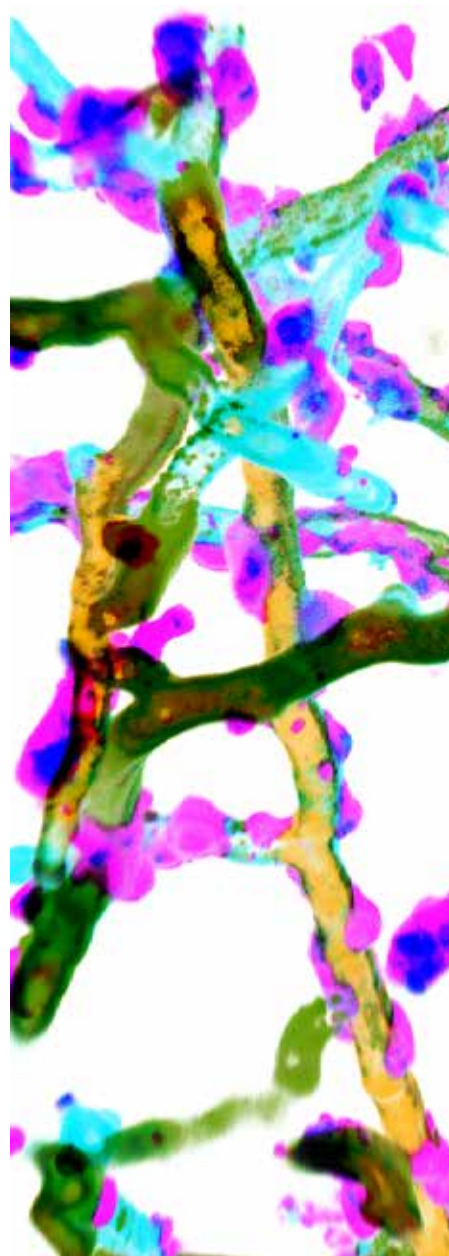





MEDIZINISCHE
UNIVERSITÄT

INNSBRUCK

Research Report 2016

Medical University of Innsbruck

Contents

Foreword	5
Medical Theoretical Research Units	
Biocenter	
Medical Biochemistry	8
Neurobiochemistry	12
Clinical Biochemistry	14
Biological Chemistry	16
Cell Biology	18
Genomics and RNomics	22
Molecular Biology	24
Experimental Pathophysiology and Immunology	28
Molecular Pathophysiology	30
Developmental Immunology	32
Bioinformatics	34
Department of Physiology and Medical Physics	
Physiology	36
Biomedical Physics	40
Department of Medical Genetics, Molecular and Clinical Pharmacology	
Cell Genetics	42
Genetic Epidemiology	44
Human Genetics	48
Biochemical Pharmacology	52
Molecular and Cellular Pharmacology	54
Department of Anatomy, Histology and Embryology	
Clinical and Functional Anatomy	56
Neuroanatomy	58
Histology and Embryology	60
Department of Hygiene, Microbiology and Social Medicine	
Hygiene and Medical Microbiology	62
Virology	66
Institute of Pharmacology	68
Department of Medical Statistics, Informatics and Health Economics	
Medical Statistics and Informatics	72
Department of Pathology	
General Pathology	76
Institute of Legal Medicine	78
Clinical Research Units	
Center of Operative Medicine	
Visceral, Transplant and Thoracic Surgery	82
Cardiac Surgery	88
Vascular Surgery	90
Plastic, Reconstructive and Aesthetic Surgery	92
Trauma Surgery	94
Urology	96
Orthopedic Surgery	98
Anaesthesiology and Critical Care Medicine	102
General and Surgical Critical Care Medicine	106

Center of Internal Medicine	
Internal Medicine I	110
Internal Medicine II	114
Internal Medicine III	118
Internal Medicine IV	122
Internal Medicine V	126
Joint Institution for Emergency Medicine and Critical Care Medicine	130
Center of Psychiatry and Psychotherapy	
Psychiatry I	134
Psychiatry II	138
Medical Psychology	140
Child and Adolescent Psychiatry	142
Center of Neurology and Neurosurgery	
Neurology	144
Neurosurgery	148
Center of Obstetrics and Gynecology	
Obstetrics and Gynecology	152
Gynecological Endocrinology and Reproductive Medicine	156
Center of Otorhinolaryngology and Hearing, Speech and Voice Disorders	
Otorhinolaryngology	160
Hearing, Speech and Voice Disorders	164
Center of Diagnostic Radiology	
Diagnostic and Interventional Radiology	166
Neuroradiology	170
Center of Dentistry and CMF-Surgery	
Prosthodontics, Restorative Dentistry and Periodontology	174
Orthodontics	176
Cranio-Maxillo-Facial and Oral Surgery	178
Center of Pediatrics	
Pediatrics I	182
Pediatrics II	186
Department of Nuclear Medicine	
188	
Department of Therapeutic Radiology and Oncology	
192	
Department of Dermatology and Venereology	
194	
Department of Ophthalmology and Optometry	
198	
Women's Health Center	
202	
Institute for Neuroscience	
204	
FWF-funded Programmes	
Molecular Cell Biology and Oncology – DK MCBO	208
Host Response in Opportunistic Infections – DK HOROS	210
Signal Processing in Neurons – DK SPIN	212
SFB-F44–Cell Signaling in Chronic CNS Disorders	214
Core Facilities	
218	



Foreword



Dear readers,

It is with great pleasure we present our research activities from 2015–2016 to you, collected together in the Medical University of Innsbruck's (MUI) second research report.

MUI has made a deep commitment to fostering research innovation and excellence with the aim of creating knowledge that can advance health. This commitment is lived up to in collaboration with the Tirol Kliniken (formerly Tiroler Landeskrankenanstalten). MUI continues to build on its established main research areas of genetics, epigenetics and genomics, as well as infectiology, immunology and organ/tissue replacement, neurosciences and oncology.

Scientific research at the MUI is very successful both nationally and internationally in the highly competitive field of research funding. MUI gains approximately € 40 million of external research funding each year. The following externally-funded research programmes and projects are currently established at the MUI: three FWF-funded doctoral programmes (HOROS, SPIN, MCBO), one special research programme (SFB-F44 "Cell Signaling in chronic CNS disorders"), 26 EU projects, the K Centre Oncotyrol, the K Project VASCage and five Christian Doppler labs.

The current research report was created as part of a project from the Knowledge Transfer Centre West (WTZ West). This project, which brings together the western Austrian Universities and associates, is financed by the Federal Ministry of Science, Research and Economy (BWF). The objectives of the WTZ are, among others, to professionalise knowledge and technology transfer by simplifying the search for university-based cooperation partners. One of the results of the project is the publishing of two research reports and a competence map.

The following pages present the profiles and results for each of MUI's clinical departments and institutes and underline the discoveries and advances that have come about thanks to the enormous effort of our scientists.

I would like to thank all of the scientists for their contribution and their continuing efforts in the name of our University as well as all of the people involved in putting this report together.

Enjoy reading our second research report!

Univ.-Prof.ⁱⁿ Dr.ⁱⁿ Christine Bandtlow
Vice Rector for Research and International Relations



Medical Theoretical Research Units

Medical Biochemistry



Head of Division:
Univ.-Prof. Dr. Ludger Hengst

Contact:
Biocenter, Innrain 80-82
6020 Innsbruck

Ludger.Hengst@i-med.ac.at
Phone: +43 512 9003 70110
Fax: +43 512 9003 73130
www.i-med.ac.at/imcbc/medclinchem-
folder/medclinchem.html

Research Branch (ÖSTAT Classifications

104002, 106002, 106037,
106052, 301114

Keywords

Cell cycle, cell proliferation, signal transduction, ribosom, phospho-dynamics

Research Focus

- Cell Cycle & Proliferation (Ludger Hengst)
- Signal Transduction & Proliferation (Wolfgang Doppler)
- Phospho-Dynamics (Peter Gruber)
- Ribosomal Proteins (Wolfgang Piendl)
- Eco- & Nutritional Biochemistry (F. Überall)
- Biomedical toxicology (Johanne Gostner)

General Facts

Research in the Division of Medical Biochemistry is focused on signalling pathways regulating cell proliferation, apoptosis and differentiation in mammalian tissues with special reference to malignant cells. In addition, RNA-protein interactions are investigated with a focus on protein translation and ribosome function. Research in the

area of biochemical toxicity focuses on cellular responses to chemical exposures and related immunometabolic consequences.

Research

Cell Cycle and Proliferation

Ludger Hengst

Precisely coordinated cell division and differentiation processes are essential for growth, development and integrity of multicellular organisms. Before cells commit to divide, they are exposed to a flood of diverse and sometimes conflicting signals aimed to regulate cell growth, differentiation, cell proliferation or cell fate. Multiple external as well as internal signals can impinge on the central cell cycle control machinery in order to promote or block cell proliferation. All signals need to be properly processed and integrated to maintain body and organ homeostasis. Incorrect signal interpretation, processing or integration can lead to hypo- or hyperproliferative disorders, including diseases like cancer or anaemia.

The decision to continue proliferation or to exit from the cell cycle into quiescence is usually made during a specific window of the eukaryotic cell division cycle. The cell cycle can be subdivided into four phases. DNA replication during S-phase is separated by gap phases G1 and G2 from the segregation of the duplicated DNA and other cellular components in M-phase (mitosis and cytokinesis). Cells can decide to withdraw from proliferation or to commit to another round of cell division until they progress over the restriction point, a specific point in G1 phase (Fig. 1). Progression over the restriction point renders the cell cycle mitogen-independent and cells committed to

undergo another complete cell cycle. We investigate molecular mechanisms that link diverse signalling networks to the central cell cycle control machinery. At the core of this machinery is a conserved family of protein kinases, called cyclin-dependent kinases (CDKs). CDKs become activated by binding of a positive regulatory subunit, the cyclin. Sequential activation and inactivation of specific CDK complexes is required for cell cycle progression. p21 (CDK-interacting protein, Cip1), p27 (Kinase inhibitory protein, Kip1) and p57 (Kip2) constitute one out of two families of CDK inhibitors (CKI) that bind to CDKs and control CDK kinase activity. Their expression, localisation and modifications play a central role in regulating CDK kinase activity especially during G1-phase and the decision between proliferation and cell cycle exit. In addition to their canonical function in CDK kinase regulation, these inhibitors can also exert CDK independent functions. For example, the CDK inhibitor p27 can regulate cell motility and cell migration, linking this tumour suppressor protein not only to hyperproliferation but also to cancer metastasis. Among others, we identified the CDK inhibitor protein p27Kip1. Its activity, localisation or stability can be regulated by diverse mitogen signalling pathways. We investigate how these pathways control Cip/Kip family protein expression, localisation, modification, activity or function and study their physiological roles in normal cells and cancer cells. p27 regulates cell cycle progression over the restriction point. Abundant p27 binds and inactivates CDKs and can prevent cell proliferation. The CDK inhibitor protein becomes unstable upon cyclin / CDK2 activation, as cells traverse the restriction point

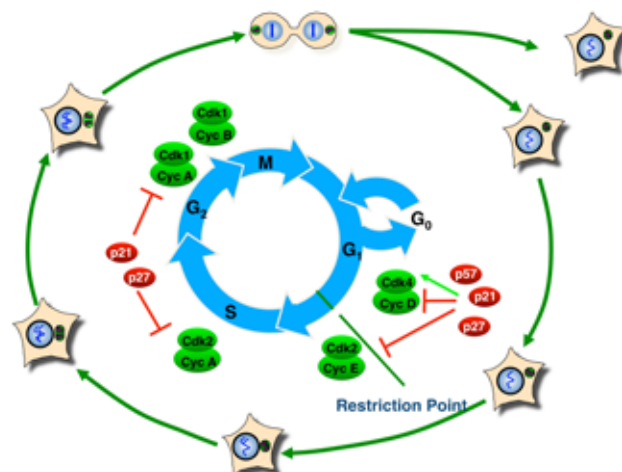

Fig. 1: Overview of the mammalian cell cycle. Cent-ral CDK/cyclin complexes are indicated next to the cell cycle position when they are active and the Cip/Kip CDK inhibitors are shown next to CDK/Cyclin complexes, which they bind. The green arrow indicates that p21 and p27 are not only inhibitors but also acti-vators of cyclin D / CDKs.

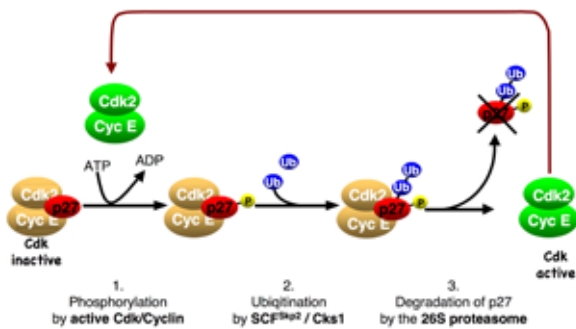

Fig. 2: A feedback loop controls CDK2 activation at the restriction point. Active CDK2 triggers the degradation of its own inhibitor p27, promoting the switch-like activation of CDK2 kinase at the restriction point.

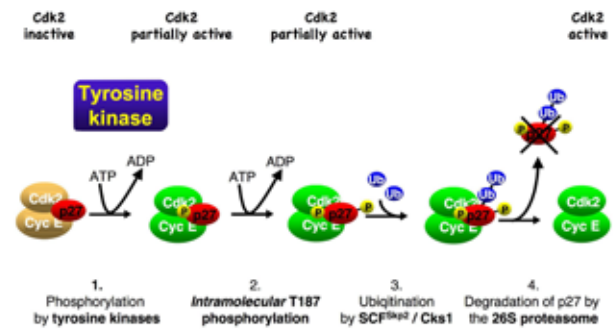

Fig. 3: Oncogenic tyrosine kinases like JAK2, Src or BCR-Abl can phosphorylate p27. This leads to the activation of bound CDK2. The activated CDK2 can phosphorylate the bound inhibitor p27, leading to its degradation and strong CDK activation.

and progress towards S-phase. A positive feedback loop couples p27 ubiquitin dependent degradation to CDK activation (Fig. 2). The molecular mechanism that can initiate this feedback loop in presence of abundant CDK inhibitors and thus inactivates CDKs has long remained a puzzle.

We observed that oncogenic tyrosine kinases including BCR-Abl, Src or JAK2 can activate p27-bound CDKs by directly phosphorylating the inhibitor. This tyrosine phosphorylation ejects an inhibitory helix of p27 from the catalytic cleft of the CDK and permits the p27-bound CDK complex to bind ATP and to phosphorylate substrates. Among these substrates is p27 itself. Phosphorylation of p27 by the bound CDK generates a phosphodegron which can initiate the ubiquitin proteasomal degradation of the CDK inhibitor (Fig. 3). Using this mechanism that can be abused by diverse oncogenic tyrosine kinases mitogen signals can inactivate and destabilise the inhibitor p27 and thereby promote CDK activation and cell cycle progression. Additional mechanisms include translational control or involve regulation by the ubiquitin proteasome system.

Ongoing Research:

Regulation of cell cycle progression through G1 phase by tyrosine kinases, translational control in and of the cell cycle; temporal and spatial regulation of Cdk-inhibitory proteins during cell cycle progression and in apoptosis, regulation of ubiquitin ligase activity in G1, molecular mechanism of statin-induced cell cycle arrest, cell cycle control by erythropoietin and its receptor EpoR. Mouse knock-in models of tumour development

Major Achievements:

We discovered a novel mechanism that triggers p27 degradation, CDK activation and cell cycle progression and identified different oncogenic tyrosine kinases including

Src, BCR-Abl or JAK2, which induce p27 tyrosine phosphorylation. We identified novel mechanisms that control the localisation of p27. Recently, we elucidated the molecular mechanisms that induce p27 stabilisation in the presence of statins. This involves the selective degradation of the ubiquitin ligase subunit Skp2 and results from inhibition of protein geranyl geranylation.

We also identified novel p27 mRNA binding proteins that regulate the IRES- and Cap-dependent translation of p27 and investigated the role of p27 in apoptosis.

Current Research Projects:

- Function and regulation of CDK-inhibitory proteins.
- Role of translational control for the decision between cell proliferation and withdrawal from the cell cycle.
- Regulation of cytokine receptor signalling.
- Ubiquitin E3 ligase regulation in response to stress.

STAT1 in Cancer

Wolfgang Doppler

Strengthening a productive anti-tumour immune response as well as suppressing tumour-promoting activities of immune cells represent important therapeutic options in cancer treatment. For the rational design of appropriate strategies to achieve these goals, a more refined knowledge of the mechanisms regulating the recruitment, differentiation, expansion and function of tumour-infiltrating immune cells is mandatory. In this context, we investigate the role of a key mediator of the action of interferons on cells of the innate and acquired immune system, the signal transducer and activator of transcription 1 (STAT1). It acts as a transcription factor to induce the expression of genes required for antigen processing, maturation and recruitment of immune effector cells, and of genes required for the antiviral defence. STAT1 also co-operates with the

cellular machinery -regulating proliferation and apoptosis.

In cancer, STAT1 has been shown to fulfil opposite roles in either promoting or impeding tumour development, depending on the stage of tumour development and the particular type of tumour: As a mediator of the interferon-dependent anti-tumour immune response, STAT1 prevents or restricts the development of spontaneously-formed tumours. However, particularly at later stages of tumour development, where the anti-tumour immune response is blunted by the tumour and immune cells are frequently subverted to facilitate the growth and survival of the tumour, STAT1 can contribute to tumour-promoting effects.

Ongoing Research:

We are investigating the role of STAT1 in the infiltration, differentiation and biological function of tumour-infiltrating immune cells. Our focus is on HER2-positive breast cancer. We are particularly interested in changes to the composition and function of tumour infiltrating immune cells upon treatment by chemotherapeutic agents, which act on the tumour epithelium but also influence the anti-tumour immune response.

Major Achievements:

We could demonstrate anti-tumor as well as tumor promoting properties of STAT1 in spontaneously growing mammary tumors. They are promoted by two different subsets of immune cells, namely CD8+ T cells and tumor associated macrophages (TAMs). CD8+ T cells contribute to the anti-neoplastic activity of chemotherapeutic agents, i.e. doxorubicin and lapatinib, and this is critically dependent on STAT1. By this means, STAT1 serves in the anti-tumor response. STAT1 was also shown to be required for the regeneration of the B-cell compartment after doxorubicin induced bone-marrow toxicity by promoting the

development of early B-cell precursors in the bone marrow. It is thereby important for the recovery of the B-cell lineage after treatment with this anti-cancer drug. On the other hand, STAT1 is positively influencing the infiltration of mammary tumors with TAMs by transcriptionally inducing the expression of the macrophage growth factor CSF 1. We could show that intense local proliferation of fully differentiated macrophages rather than low-pace recruitment of blood-borne precursors drives the accumulation of TAMs, which themselves are promoting tumor growth. The tumor promoting effect of STAT1 via influencing differentiation and infiltration of TAMs was supported by the results of a retrospective study. There we could show an association of STAT1 mRNA levels with macrophage infiltration and bad prognosis in breast cancer.

Current Research Projects:

We are exploring the mechanisms by which STAT1 contributes to the chemotherapy-induced anti-tumor immune response. In particular, we are investigating the role of the STAT1 target genes CXCL9, CXCL10 and CXCL11 in the recruitment and differentiation of CD8+ T cells.

Biochemical toxicology

Johanna Gostner

In recent years, special attention has been paid to volatile organic compounds (VOC) as exposures were associated with adverse effects such as respiratory tract irritation and sensitisation leading to the development of allergies and asthma.

To investigate cellular reactions that are initiated by low-dose of volatile compounds *in vitro*, we developed an exposure platform for airborne treatments of cell models. In a functional genomics approach, we could show that even in very low concentrations, dose-specific response patterns can be identified. Thus, this new approach can contribute to unravelling the mechanisms of VOC bioactivity, which is of relevance

for both toxicological and pharmaceutical research. A major goal is the identification of exposure biomarkers, whereby the tryptophan breakdown pathway via indoleamine 2,3-dioxygenase is a potent target, in particular for the assessment of immunomodulatory effects.

Major Achievements:

An exposure platform for volatile compounds was developed. Specific response patterns could be identified for low-dose exposures.

Future Goals:

- Development of 3D lung models
- Investigating metabolic and transcriptional changes induced by different types of VOC.

Ribosomal Proteins

Wolfgang Piendl

Interaction of Ribosomal Proteins with rRNA and mRNA

We are investigating ribosomal protein L1 from different (hyper)thermophilic archaea and bacteria. They exhibit a 10 to 100 fold higher affinity to their specific binding sites on rRNA and mRNA compared to that of their mesophilic counterparts. This stronger protein-RNA interaction might substantially contribute to the thermal tolerance of ribosomes in thermophilic organisms. Our investigations are focusing on the identification and characterization of those structural features of RNA-binding proteins that modulate the affinity for their specific RNA binding site. In this context we determined the crystal structures of L1-rRNA and L1-mRNA complexes at high resolution (in collaboration with our Russian partners)

Function of Ribosomal Protein L1

L1 is a two-domain protein with N and C termini located in domain I. In close collaboration with a Russian group we succeeded in constructing a truncation mutant of L1 representing domain I by deletion of the central part of L1 (= domain II). We



Fig. 5: Ribosomal protein L1 from the archaeon *Sulf-olobus acidocaldarius* in complex with 23S rRNA

could demonstrate that domain I alone is sufficient for specific RNA binding, whereas domain II stabilizes the L1-23S rRNA complex.

Major Achievements:

Solution of the structure of the L1 protuberance in the ribosome (with the Russian collaborator); see Fig. 5.

Construction of a truncated mutant of ribosomal protein L1 and elucidation of its role in RNA binding

Control of ribosomal protein synthesis in mesophilic and thermophilic archaea

As bacteria and eukarya, archaea have to coordinate the synthesis of about 60 ribosomal proteins with each other and with three rRNAs. Research is focusing on the MvaL1 operon (encoding ribosomal proteins L1, L10 and L12) and on the MvaL3 operon (encoding 5 ribosomal proteins) from mesophilic and thermophilic Methanococcus species. As in bacteria, regulation of the operons takes place at the level of translation. The regulator protein MvaL1, and MvaL4, respectively, binds preferentially to its binding site on the 23S rRNA, and, when in excess, binds with lower affinity to its regulatory binding site on its mRNA (in the case of MvaL1 a structural mimic of the 23S rRNA binding site) and thus inhibits translation of all cistrons of the operon.

Future Goals:

- define the translational step at which archaeal L1 inhibits its own synthesis
- study the mechanism of MvaL4-mediated autoregulation of its operon in Archaea

Eco- and Nutritional Biochemistry &

Nutrigenomics

Florian Überall

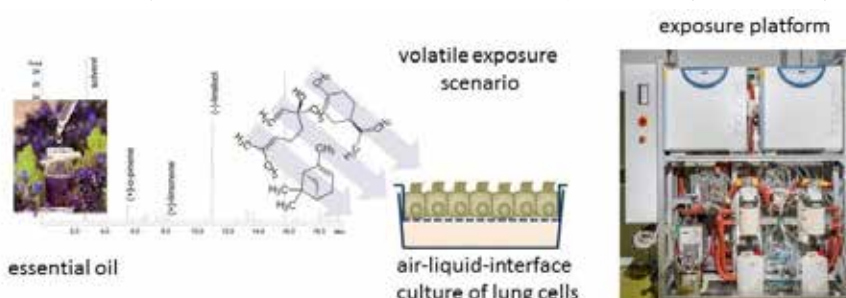

Fig. 4: We developed a novel incubator platform to expose cell cultures to volatile organic compounds. With this equipment we investigate responses of cell cultures to VOC treatment

- Risk/benefit assessment of the impact of natural products on cells through the use of cellular model systems
- Identification of gene expression signatures and genome wide pathway and network analysis
- Cellular detox systems:
Phase I: Cytochrome P450 isoenzymes (Johannes Hochleitner);
Phase II: Keap1/Nrf2 signalling (Martina Naschberger) and a detailed understanding of cellular redox regulated pathways
- Development of new kitchen appliances for healthier cooking (cooperation with PHILIPS Austria GmbH) and of a small-scale bio-sensor (cooperation with CTR) (all + Maria Lerchbaumer)

Risk-benefit assessment of natural products – i.e. volatile organic compounds and phytochemicals – is an integral part of biomedicine and potential therapies. Therefore, we have developed suitable and reliable cellular models to achieve a profound understanding, in particular of redox-regulated pathways. The identification of gene expression signatures and genome-wide pathway and network analysis is at the core of our analyses. Thereby, our specific focus tackles the cell's own detoxification systems. In this case, phase I detoxification, regulated via cytochrome P450 isoenzymes is investigated in depth (Johannes -Hochleitner), as well as phase II, orchestrated by the Keap1/Nrf2 signalling pathway (Martina Naschberger). Striving for translation of our research into applications for society, the development of new kitchen appliances for healthier cooking, a fruitful cooperation with PHILIPS Austria GmbH, was initiated in 2013 (Maria Lerchbaumer). Within this framework, the advancements have been extrapolated into small-scale bio-sensor in cooperation with CTR. analyses. Thereby, our specific focus tackles the cell's own detoxification sys-

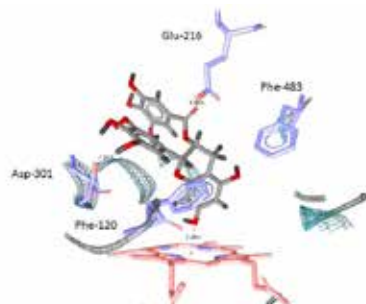

Fig. 6: shows green tea polyphenol (-) Epigallocatechin-3-gallate in the active site cavity of the human drug metabolizing enzyme Cytochrome P450 2D6. The genetic algorithm GOLD was used for docking the flexible non-generic (-) EGCG in the binding site of CYP2D6.

tems. In this regard, Phase I detoxification, regulated via cytochrome P450 isoenzymes is investigated in depth, as well as Phase II, orchestrated by the Keap1/Nrf2 signalling pathway. We strive to translate the findings of our research into applications of use for society and in this context we have taken part in the development of new kitchen appliances for healthier cooking as part of a fruitful cooperation with PHILIPS Austria GmbH. This project was initiated in 2013. Within this framework, the advancements thus obtained have been extrapolated into the development of a small-scale biosensor in accordance with CTR.

Selected Publications

Caspases uncouple p27Kip1 from cell cycle regulated degradation and abolish its ability to stimulate cell migration and invasion

Podmirsek, S.R., Jäkel, H., Ranches, G.D., Kullmann, M.K., Sohm, B., Villunger A., Lindner H. and Hengst, L.
ONCOGENE: 2016; 35: S. 4580-4590

Cellular reactions to long-term volatile organic compound (VOC) exposures

Gostner, Johanna M., Zeisler, Johannes, Alam, Mohammad Tauqeer, Gruber, Peter, Fuchs, Dietmar, Becker, Kathrin, Neubert, Kerstin, Kleinhapl, Markus, Martini, Stefan, Ueberall, Florian,
SCIENTIFIC REPORTS: 2016; 6: S. 37842

Tryptophan Metabolism in Allergic Disorders

Gostner, Johanna M., Becker, Katrin, Kofler, Heinz, Strasser, Barbara, Fuchs, Dietmar,
INTERNATIONAL ARCHIVES OF ALLERGY AND IMMUNOLOGY: 2016; 169: S. 203-215

The BH3-only protein BIM contributes to late-stage involution in the mouse mammary gland

Schuler, F., Baumgartner, F., Klepsch, V., Chamson, M., Mueller-Holzner, E., Watson, C. J., Oh, S., Hennighausen, L., Tymoszuk, P., Doppler, W., Villunger, A.,
CELL DEATH AND DIFFERENTIATION: 2016; 23: S. 41-51

Novel antibodies directed against the human erythropoietin receptor: creating a basis for clinical implementation

Maxwell, Perry, Melendez-Rodriguez, Florinda, Matchett, Kyle B., Aragones, Julian, Ben-Califa, Nathalie, Jaekel, Heideleinde, Hengst, Ludger, Lindner, Herbert, Bernardini, Andre, Brockmeier, Ulf, Fandrey, Joachim, Grunert, Fritz, Oster, Howard S., Mittelman, Moshe, El-Tanani, Mohamed, Thiersch, Markus, Gasser, Edith M. Schneider, Gassmann, Max, Dangoor, David, Cuthbert, Robert J., Irvine, Alexandra, Jordan, Anne, Lappin, Terence, Thompson, John, Neumann, Drorit,
BRITISH JOURNAL OF HAEMATOLOGY: 2015; 168: S. 429-442

Bisphenol A suppresses Th1-type immune response in human peripheral blood mononuclear cells in vitro

Gostner, Johanna M., Ragg, Emanuel, Becker, Kathrin, Ueberall, Florian, Schennach, Harald, Pease, James E., Fuchs, Dietmar,
IMMUNOLOGY LETTERS: 2015; 168: S. 285-292

Complement-Opsonized HIV-1 Overcomes Restriction in Dendritic Cells

Posch, Wilfried, Steger, Marion, Knackmuss, Ulla, Blatzer, Michael, Baldauf, Hanna-Mari, Doppler, Wolfgang, White, Tommy E., Hoertnagl, Paul, Diaz-Griffero, Felipe, Lass-Floerl, Cornelia, Hackl, Hubert, Moris, Arnaud, Keppler, Oliver T., Wilflingseder, Doris,
PLOS PATHOGENS: 2015; 11: S. e1005005

Selected Fundings

- Funktion der p27 Tyrosin Phosphorylierung durch BCR-Abl, JAK2 und FLT3 in der Tumorentstehung – FWF Einzelprojekt P 24031. L. Hengst. 342,412.00€
- DK MCBO Teilprojekt. Molecular Mechanism of the statin-induced cell cycle arrest. L. Hengst. FWF 118,135€
- Protein Kinase C Epsilon-induced phosphoproteome P. Gruber. FWF Einzelprojekt P 25491. 267,177.75€
- Volatile Öle. Herta Firmberg Programm. Johanna Gostner. FWF T 703. 223,500€

- VocOnCell: Design, realization and validation of a novel incubator system to expose cell cultures to volatile compounds, F. Überall, FFG 834 169, bridge project. 475,000€.
- TRENDS IN NUTRITION: Implementation of novel food processing technologies for healthy nutrition, F. Überall, FFG 840590 headquarter project of PHILIPS Austria. 679,300€

Collaborations

- Joyce M Slingerland, University of Miami, USA
- R. W. Kriwacki, St. Jude Hosp. of Sick Children, Memphis, USA
- Hartmut Halfter, Universität Münster, Germany
- Pierre Roger, Bruxelles, Belgium
- Stephen J. Elledge, Harvard, Boston, USA
- Joan Conaway, Stowers Institute Kansas City, USA
- Drorit Neumann, Tel Aviv University, Israel
- Terrance Lappin, Queens University Belfast, UK
- Elizabeth M Jaffee, Johns Hopkins, Baltimore, USA
- Johannes Kirchmair, University of Hamburg, Germany
- Gennady Lapa, Gause Institute of New Antibiotics, Moscow
- Johann Hofmann (senior advisor)
- Prof. Dr. M. Garber, Institute of Protein Research, Russian Academy of Sciences, Pushchino, Moscow Region, Russia
- Ulrich-Merzenich G., "Omics"-technologies in phytomedicine, Universitätsklinikum Bonn, Germany
- Moscat J., Protein kinase C signaling, Genome Research Institute Cincinnati, USA
- Tonissen K., Eskitis Inst. for Drug Discovery, Griffith Univ., AUS
- Schwarzenbruber P., Pyrosequencing & microbiome, Microstetech, Olten, CH

Neurobiochemistry



Head of Division:
Univ.-Prof.ⁱⁿ Dr.ⁱⁿ Christine Bandtlow

Contact:
 Biocenter, Innrain 80-82
 6020 Innsbruck

Christine.Bandtlow@i-med.ac.at
 Phone: +43 512 9003 70281
 Fax: +43 512 9003 73110
 www.i-med.ac.at/neurobiochemistry

Research Branch (ÖSTAT Classification)

106002, 106023, 301114,
 301402, 106010

Keywords

Neuroscience, structural plasticity, somatosensory neurons, axonal path finding, chondroitin sulphate proteoglycans, neuroprotection

Research Focus

Ongoing studies are aimed at understanding the mechanisms of how the CNS regeneration inhibitors such as MAG, Nogo and its receptors, NgRs regulate axon guidance and collateral branching during development. Another focus is to elucidate the role of the Protein kinase N in brain development and post stroke recovery.

Research

Biooptics Core Facility

Martin Offterdinger

The Division of Neurobiochemistry hosts the Biooptics facility, and provides university-wide access to advanced equipment,

training, education and expertise in light microscopy to all scientists on campus.

Two laser scanning confocal microscopes (Leica SP5, Zeiss, LSM510 Meta), a multifunctional microscope (Till, iMIC) for live cell imaging, which is equipped for TIRF, spinning disk, and FRAP and two wide-field microscopes are offered. In addition, an integrated stereology microscope/software system for neuron tracing (NeuroLucida) is offered together with the Institute of Pharmacology. State-of-the-art super-resolution microscopy is available in collaboration with the Leopold-Franzens-University Innsbruck. A gSTED was installed, which is based on a Leica SP8 inverted confocal microscope outfitted with a very flexible white light laser source and additional depletion laser lines. This allows using the STED

(STimulated Emission Depletion) principle to perform imaging beyond the diffraction limit. Under optimal conditions a resolution of 50 nm laterally (xy) and 130 nm axially (z) can be achieved. In addition, STORM technology has been implemented on the iMIC.

Software support is offered from basic user training to complex calculations. We currently support Fiji, CellProfiler and MATLAB. A server-based deconvolution software package (Huygens Professional) enabling the improvement of the resolution of light microscopic images. Challenging interactive 3D image analyses are done using Imaris. Microscopy-related teaching is offered in several PhD programmes and prior to independent usage of any microscope all users receive an instrument-specific training.

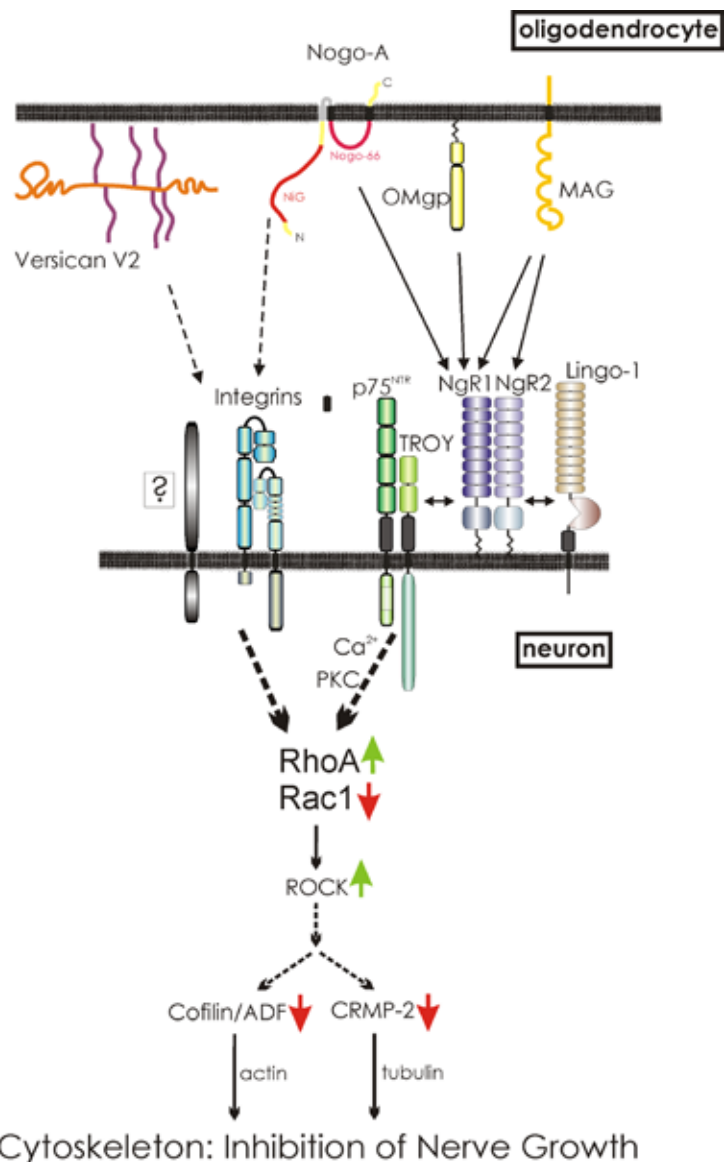

Fig. 1: Signalling by Nogo receptors

Research

Modulation of Structural Plasticity by Nogo and Nogo Receptors

Christine Bandtlow

Our group has a long standing interest in understanding the molecular mechanisms regulating axonal growth and sprouting in the mammalian nervous system in the intact and diseased brain (i.e. brain injury, epilepsy or multiple sclerosis). We pursue a variety of mouse genetic approaches combined with surgical, histological, biochemistry-based, and behavioural studies to investigate the function of axon growth inhibitors, such as MAG and Nogo, and their cognate receptors, the GPI-anchored cell-surface receptors of the Nogo Receptor family (NgR1-NgR3) and their interacting binding partners. Accumulating evidence suggests that these components restrict axonal regeneration and compensatory sprouting following injury not only in the CNS, but also in the PNS. Previous studies by us and others support also the idea that in the intact CNS, NgR1/2 signalling acts as a 'brake' to restrict structural synaptic plasticity by modulating spine morphology and dynamics. Interestingly, we also identified NgR2, which is abundantly expressed by sensory neurons of the peripheral nervous system (PNS), as a suppressor of terminal branching of nociceptive nonpeptidergic afferents during skin innervation. Loss of NgR2 leads to increased innervation of somatosensory endings in the epidermis, associated with a hypersensitivity to mechanical pain and cold sensation. We currently delineate the structural and molecular mechanisms that lead to enhanced mechanosensitivity in NgR2-null mice.

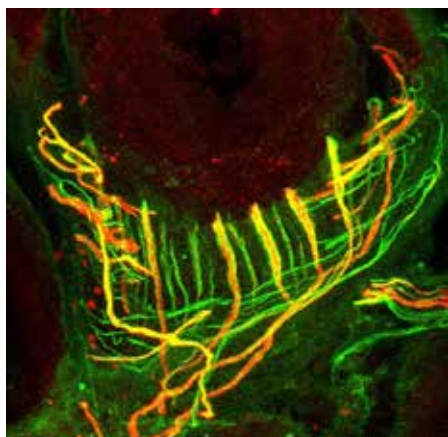

Fig. 2: Confocal imaging of low-threshold mechanoreceptors (LTMRs) forming lanceolate complexes at a hair follicle in hairy skin stained with Tuj1 (green) and NFH (red).

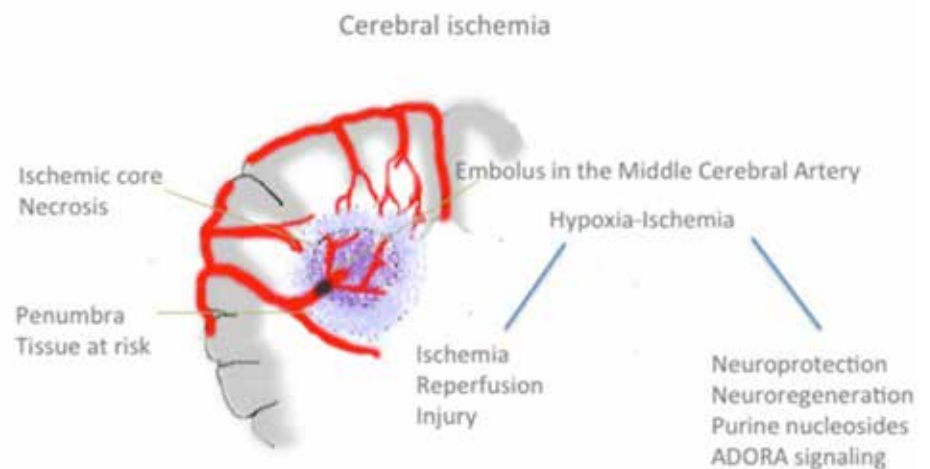

Fig. 3: Even a short blockade of oxygen flow in the brain results in a rapid decline of cellular ATP and a subsequent loss of neuronal function and viability. Tissue in the ischemic core is beyond therapeutic rescue, however the penumbral tissue is affected by ischemia but still viable and therefore key for target interventions.

Purine Mediated Neuroprotection

Gabriele Baier-Bitterlich

Ischemia reperfusion severely hampers tissue survival in affected brain areas. Rising interest in post-stroke brain plasticity has powered investigations of therapeutic approaches that promote endogenous neurorepair. The main research focus of the lab, over the last decade, has been the analysis of adenosine receptor-mediated cellular signalling. Based on our recent experimental work, we have discovered a candidate role of Protein kinase N in the regulation of neuroprotective processes. Our current research objective is to define the neuron-specific function of PKN1 in brain development and post-stroke recovery.

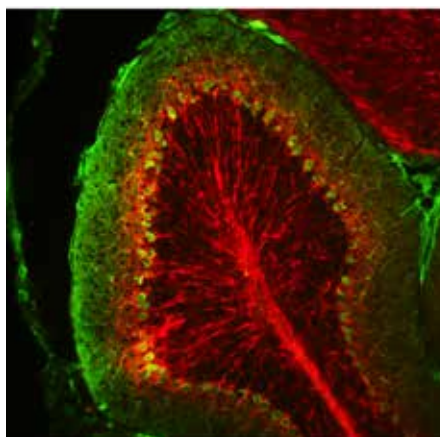

Fig. 4: Immunostaining of white matter (red; NF200) and Purkinje cells (green; Calbindin).

Selected Publications

A novel role for the histone acetyltransferase Hat1 in the CENP-A/CID assembly pathway in Drosophila melanogaster
Boltengagen, Mark, Huang, Anming, Boltengagen, Anastasiya, Trixl, Lukas, Lindner, Herbert, Kremser, Leopold, Offerdinger, Martin, Lusser, Alexandra,
NUCLEIC ACIDS RESEARCH: 2016; 44: S. 2145-2159

Schwann Cell Expressed Nogo-B Modulates Axonal Branching of Adult Sensory Neurons Through the Nogo-B Receptor NgBR
Eckharter, Christoph, Junker, Nina, Winter, Lilli, Fischer, Irmgard, Fogli, Barbara, Kistner, Steffen, Pfaller, Kristian, Zheng, Binhai, Wiche, Gerhard, Klimaschewski, Lars, Schweigreiter, Ruediger,
FRONTIERS IN CELLULAR NEUROSCIENCE: 2015; 9: S. 454

Enhanced Axon Outgrowth and Improved Long-Distance Axon Regeneration in Sprouty2 Deficient Mice
Marvaldi, Letizia, Thongrong, Sitthisak, Kozłowska, Anna, Irschick, Regina, Pritz, Christian O., Baeumer, Bastian, Ronchi, Giulia, Geuna, Stefano, Hausott, Barbara, Klimaschewski, Lars,
DEVELOPMENTAL NEUROBIOLOGY: 2015; 75: S. 217-231

Selected Funding

- FWF, W1206: Doctoral College 'Signal processing in neurons'
- FWF, P2600_B24: „Analyse der Rolle der PRK1 in der Neuroprotektion“

Core Facilities

Biooptics/Light microscopy

Clinical Biochemistry



**Vice Head of Division (interim):
ao. Univ.-Prof. Dr. Herbert Lindner**

Contact:

Biocenter, Innrain 80-82
6020 Innsbruck

Herbert.Lindner@i-med.ac.at
Phone: +43 512 9003 70310
Fax: +43 512 9003 70300
www.i-med.ac.at/imcbc/
clinbiochemfolder/clinbiochem.html



**Head of Division (interim):
Univ.-Prof. Dr. Ludger Hengst**

Contact:

Biocenter, Innrain 80-82
6020 Innsbruck

Ludger.Hengst@i-med.ac.at
Phone: +43 512 9003 70110
Fax: +43 512 9003 70300

Research Branch (ÖSTAT Classification)

104002, 106002, 106037,
106052, 301114

Keywords

Protein microanalysis facility, protein analysis, PTM identification, mass spectrometry, phospho-proteomics, proteome-wide quantification, capillary electrophoresis, HPLC, method development, epigenetics

Research Focus

- Multidimensional LC/CE-MS-based method development
- PTM identification of various nuclear and extracellular proteins
- Identification of histone-modification patterns at the nucleosomal level
- Method development for top-down and middle-down proteomics using ETD- and HCD- fragmentation
- Development of absolute quantification methods for targeted proteins
- Investigation of *in-vivo* O-Glycosylation of the low abundance marker NT-proBNP in blood plasma with affinity proteomic methods and mass spectrometry from patients suffering of severe heart failure
- CE method development for characterization of viral gene therapy

General Facts

The main focus of our lab was set on the development of high-resolution methods for the separation and identification of post-translationally modified proteins, which are needed to determine their biological significance. With this in mind we introduced a set of separation methods into our lab based on capillary electrophoresis (CE), reversed-phase chromatography, hydrophilic interaction liquid chromatography (HILIC) and mass spectrometry (MS). As a result of continuously improving and further developing our program we are now able to offer a wide range of analytical services intended to support other scientists involved in research at the Medical University of Innsbruck (for more information go to "Protein Micro-Analysis Facility"). Our main areas of applied science include, but are not limited to: LC/CE-ESI-MS, HPLC (e.g. RPC, HILIC, IEC, GPC), capillary electrophoresis, phospho-proteomics, chromatin immune-precipitation, co-immunoprecipitation, affinity proteomics methods, and proteome-wide quantification (e.g., SILAC, iTRAQ, TMT, Dimethyl labeling).

Research

The Potential of CE-MS for the Analysis of PTMs

Given the pivotal role of post-translational modifications (PTMs) in the regulation of a cellular environment, there is a constant push towards developing new, highly sensitive and sophisticated PTM identification methods. A relatively new approach known as CE-MS, capillary electrophoresis-electrospray ionization mass spectrometry, is an elegant method that combines electrophoresis with mass spectrometry; our research group has successfully implemented this method to posttranslational modified peptides and proteins. Citrullination, also known as deimination, is an arginine-directed PTM with the potential to alter the structure, function, and antigenicity of proteins; nonetheless, the identification of citrullinated peptides remains an analytical challenge. The conversion of arginine to the non-standard amino acid citrulline is catalysed by a family of calcium-dependent enzymes, also known as peptidylarginine deiminases (PAD); five PAD isoforms can be distinguished, each presenting different tissue-specific expression patterns. At a physiological pH, arginine expresses a positive charge due to the guanidinium group, whereas citrulline is neutral. Citrullination generates "altered-self" epitopes that may present antigenic properties thus prompting autoimmune responses against previously benign proteins. Altered calcium homeostasis accompanied by protein citrullination is associated with several neurodegenerative disorders, including Alzheimer's disease, rheumatoid arthritis, and multiple sclerosis. Our current project focuses on the identification and quantification of post-translational modifications with the help of CE-MS.

Investigation of *in-vivo* O-Glycosylation of the Low Abundance Biomarker NT-proBNP by Means of Affinity Proteomics Methods and Mass Spectrometry in the Blood Plasma from Patients Suffering of Severe Cardiac Failure

The aim of this project is to develop analytical methods for the investigation of b-type natriuretic peptides, which are commonly used as a biomarker in the detection of severe heart failure. An increase in the 'stretch stimulus' in ventricles causes cardiomyocytes to synthesize and secrete proBNP, a precursor peptide that is subsequently cleaved into the biologically active BNP (brain natriuretic peptide) and into the inactive N-terminal form, NT-proBNP. They prove to be challenging analytes due to their low

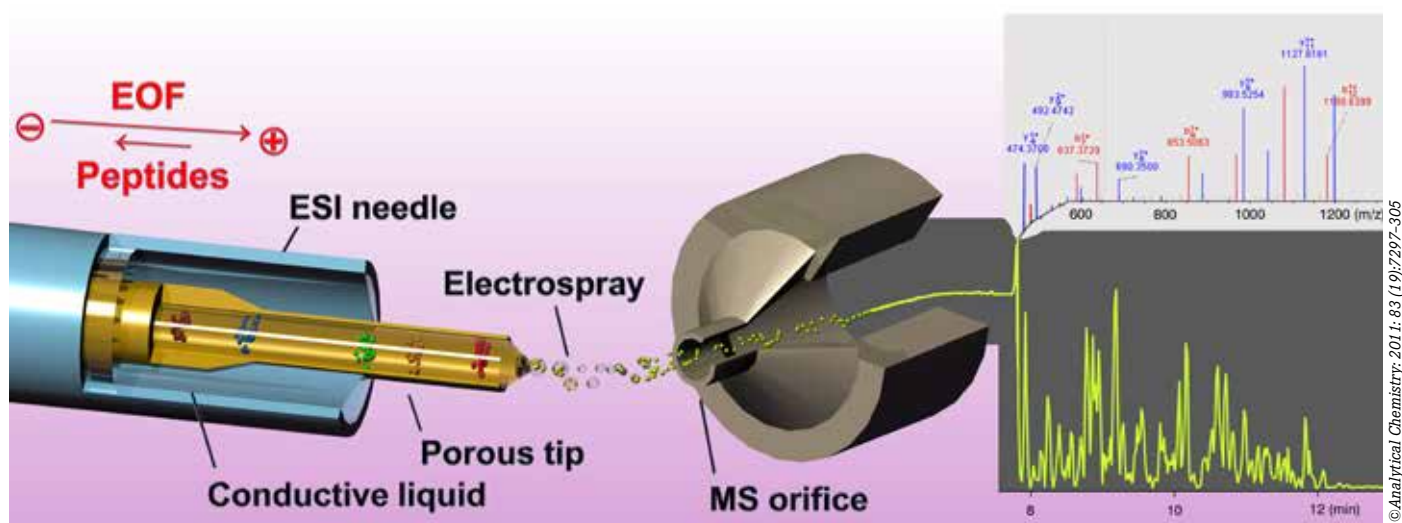

Fig. 1: The design of a sheathless interface for coupling capillary electrophoresis to mass spectrometry (Faserl et al. 2011: Anal. Chem. 83(19): 7297–305).

abundance in a complex matrix such as blood, as well as due to their high levels of variability and inconsistency, a result of diverse enzymatic processes and degradation mechanisms. Furthermore, proBNP is O-glycosylated to various extents at different sites, which is why this project especially focuses on the analysis of naturally occurring forms of this polypeptide and its posttranslational modifications. Characterization, as well as, a relative and an absolute quantification of the specific forms present in different concentrations, is critical to understanding pathobiological mechanisms and could also be relevant in the diagnosis of cardiac failure and other related diseases.

AAS - Measurement of Aluminium in Breast Tissue Biopsies, Blood, and Urine

Another point of interest that has our attention is the ascertainment of elemental analysis using graphite furnace atomic absorption spectrometry (GF-AAS). In collaboration with the Department of Medical Statistics and the Department of Obstetrics and Gynaecology we began an investigation of the association between breast cancer and the use of aluminium bearing antiperspirants in a hospital based case control study. The detection of aluminium in human tissue is not a trivial undertaking; it is indispensable that all measures be taken to avoid any potential contamination of the tissue. We combined microwave digestion with graphite furnace atomic absorption spectrometry (GF-AAS) to yield an accurate, high in precision, reproducible method for measuring aluminium in breast tissue biopsies, blood, and urine. (Microwave digestion generates clear homogeneous digests that are perfectly suited for

the determination of aluminium by means of GF-AAS.) Utilizing this method we tested the hypothesis that women with breast cancer present higher concentrations of aluminium in breasts, blood, and urine compared to healthy control patients. Because the upper outer quadrant of the breast exhibited a disproportionately high incidence of breast cysts and breast cancer, we investigated whether a regional distribution of aluminium throughout the breast could be detected in women with breast cancer.

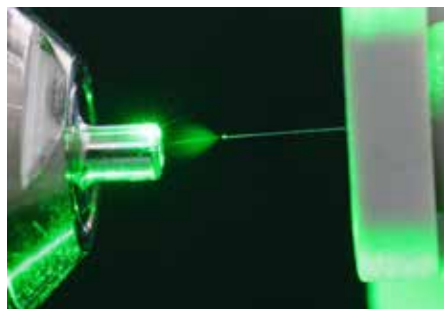

Fig. 2: Electro spray formation of the CE-MS system

Selected Publications

Identification of novel post-translational modifications in linker histones from chicken erythrocytes
Sarg, Bettina, Lopez, Rita, Lindner, Herbert, Ponte, Inma, Suau, Pedro, Roque, Alicia,
JOURNAL OF PROTEOMICS: 2015; 113: S. 162-177

Linker histone partial phosphorylation: effects on secondary structure and chromatin condensation
Lopez, Rita, Sarg, Bettina, Lindner, Herbert, Bartolome, Salvador, Ponte, Inma, Suau, Pedro, Roque, Alicia,
NUCLEIC ACIDS RESEARCH: 2015; 43: S. 4463-4476

Quantitative Proteomics Using Ultra low Flow Capillary Electrophoresis-Mass Spectrometry
Faserl, Klaus, Kremser, Leopold, Mueller, Martin, Teis, David, Lindner, Herbert H.,
ANALYTICAL CHEMISTRY: 2015; 87: S. 4633-4640

A novel role for the histone acetyltransferase Hat1 in the CENP-A/CID assembly pathway in Drosophila melanogaster
Boltengagen, Mark, Huang, Anming, Boltengagen, Anastasiya, Trixl, Lukas, Lindner, Herbert, Kremser, Leopold, Offerdinger, Martin, Lusser, Alexandra,
NUCLEIC ACIDS RESEARCH: 2016; 44: S. 2145-2159

cJun N-terminal kinase (JNK) phosphorylation of serine 36 is critical for p66Shc activation
Khalid, Sana, Drasche, Astrid, Thurner, Marco, Hermann, Martin, Ashraf, Muhammad Imtiaz, Fresser, Friedrich, Baier, Gottfried, Kremser, Leopold, Lindner, Herbert, Troppmair, Jakob,
SCIENTIFIC REPORTS: 2016; 6: S. 20930

Selected Funding

- Coupling capillary electrophoresis to mass spectrometry for protein and proteome analysis. Industrial Project with AB SCIEX /Beckman Coulter; U.S.A.; Herbert Lindner
- Investigation of in-vivo O-Glycosylation of the low abundance marker NT-proBNP by Affinity Proteomics Methods and Mass Spectrometry in blood plasma from patients with severe heart failure. Industrial Project with Roche Diagnostics GmbH Penzberg, BRD; Herbert Lindner

Collaborations

National:

- Reinhard Dallinger, Institute of Zoology, LFU, Innsbruck, Austria
- Peter Ladurner, Institute of Zoology, LFU, Innsbruck, Austria
- Nicolas Singewald, Institute of Pharmacy, LFU, Innsbruck, Austria

International:

- J. Ausio, University of Victoria, Victoria, Canada
- M. Freitas, Ohio State University Medical Center, Columbus, USA
- N. Guzman, Princeton Biochemicals Inc., New Jersey, USA
- Pedro Suau, Universitat Autònoma de Barcelona, Spain
- David Chen, Department of Chemistry, University of British Columbia, Vancouver Canada

Core Facilities

The facility is an establishment within the Division of Clinical Biochemistry and is dedicated to providing scientists with equipment, expertise, and custom services for the detection, characterization and quantification of proteins and peptides on a recharge basis. This facility possesses and operates several state of the art instrumentation, such as: a Q Exactive HF, a hybrid FT mass spectrometer LTQ Orbitrap XL ETD, an LTQ VELOS mass spectrometer (from Thermo Fisher Scientific), a Proclipse 492 protein sequencer (Applied Biosystems), nano-LC gradient systems Ultimate 3000 (Dionex), various capillary electrophoresis and HPLC systems, and, last but not least, a solar M6 dual Zeeman spectrometer (Thermo Fisher Scientific) for trace element analysis.

Biological Chemistry



Head of Division:
Univ.-Prof. Dr. Klaus Scheffzek

Contact:
Biocenter, Innrain 80-82
6020 Innsbruck

Klaus.Scheffzek@i-med.ac.at
Phone: +43 512 9003 70330
Fax: +43 512 9003 73110
www.i-med.ac.at/imcbc/
molecularcellbiologyfolder/molcellbiol.html

Research Branch (ÖSTAT Classification)

106041, 301904, 301303,
301902, 302040

Keywords

Structural biology, biomolecular crystallography, signal transduction/regulation, biochemistry, molecular biology, clinical chemistry, protein purification, high pressure liquid chromatography, bioethics, immunobiology

Research Focus

This unit studies the structural biology of disease proteins, currently focusing on neurofibromatosis type 1, an inheritable disease that has a relatively high incidence, but is poorly understood in regards to its pathogenic mechanisms. In addition we investigate complexes important for endosomal functions.

Furthermore, this unit's research is directed towards understanding the biochemistry and clinical immunology of the pteridine and tryptophan-metabolism; pteridines are structurally related to the vitamins folic acid

and riboflavin, but in contrast to these, are formed in the mammalian body.

Lastly, attention is directed towards the ethical, cultural, and social issues concerning innovative technologies in biomedicine.

General Facts

The unit consists of 5 principal investigators who study the impact biomolecular systems have on human health and disease. Our research areas include pteridine and lipid metabolism, as well as intracellular signal transduction and its regulation, particularly in the context of (small) guanine nucleotide binding (G) proteins.

In addition we strive to understand novel biotechnologies in the context of biomedicine, how they are created, and how they serve the emerging market; simultaneously we seek to explore their ethical, social, and cultural dimensions. Based on research and education in this particular field the inter-institutional and interdisciplinary network bioethics education (<http://www.i-med.ac.at/ethucation/index.html.en>) was established in 2007 which is the Austrian unit of the UNESCO Chair in Bioethics' (Haifa) International Network (<http://www.unesco-chair-bioethics.org/>).

The spectrum of our implemented methods includes biochemical techniques such as FPLC/HPLC for preparative protein purification and their analysis, eukaryotic cell cultures, various biophysical as well as bioanalytical methods, and biomolecular x-ray crystallography.

We consider teaching a major responsibility in the education of young scientists and contribute to respective activities for students of the Medical as well as of the Leopold-Franzens University Innsbruck.

Research

Structural Biology: Structure and Interactions of the Neurofibromatosis Type 1 Protein, Mechanisms of G Protein Complexes

Klaus Scheffzek

We aim at understanding the disease mechanisms of neurofibromatosis type-1 (NF1), a genetic disease with a relatively high incidence. NF1 patients have an increased tumour risk, present a variety of developmental defects, and frequently suffer of learning disabilities. The tumour suppressor gene NF1 encodes the giant protein neurofibromin (320 kDa) and is not functional in NF1 patients due to genetic alterations. Our long term goal is to define

the functional spectrum of neurofibromin in as much detail as possible. Our research activities currently include determining the structure of full length neurofibromin (FWF-grant: P28975) as well as defining its interacting partners (Dunzendorfer-Matt et al., 2016, PNAS 113, 7497-7502) (collaborations Frank Mc Cormick, UCSF, Lukas A. Huber, Innsbruck). In addition we are currently exploring the mechanisms of the neurofibromin-mediated repression of MHCII-protein-expression (collaboration with Andreas von Deimling, Heidelberg). In addition we investigate the interactions between components of cellular complexes important for lysosomal function.

We continued to expand our platform of biophysical instruments by implementing a multi angle light scattering (MALS) system, which is capable of accurately determining molecular weight and levels of microheterogeneity of multicomponent complexes.

Neuropsychimmunology

Dietmar Fuchs

Mood changes and depression are common in patients suffering from inflammatory disorders such as viral infections, auto-immune syndromes, malignant tumour diseases, and adiposity. Although the pathogenesis of these symptoms remains unclear several of our recent studies have shown a correlation between neuropsychiatric deviations in patients and elevated concentrations of neopterin and increased tryptophan breakdown (Kyn/Trp) in blood samples. These findings shed light on the relevance and importance of these observations in neuropsychimmunology. Higher blood phenylalanine levels and higher phenylalanine to tyrosine ratios have been observed in these patients as well as in healthy elderly patients. The combination of the Kyn/Trp-ratio with the Phe/Tyr-ratio can be especially useful in deciding whether

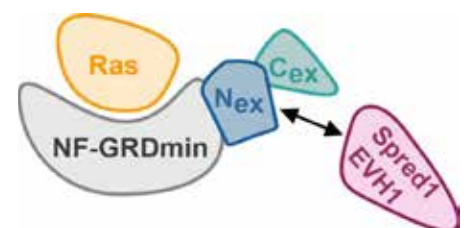

Fig. 1: The previously enigmatic extra domain (Nex/Cex) of a major Ras specific signal regulatory module (NF1-GRDmin) serves as a binding platform for its membrane recruitment factor Spred1.

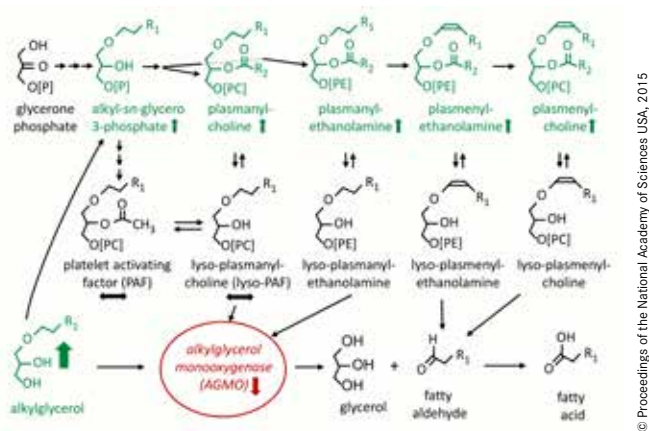

Fig. 2: Metabolic scheme of the impact of alkylglycerol monooxygenase knockdown on ether lipid metabolism

serotonergic or noradrenergic/adrenergic/dopaminergic treatments are more likely to be useful in the individual patient. More recently the effect of nutrition and life style habits (e.g. physical exercise and sports), on these abovementioned immunobiochemical pathways, has presented itself as a focal point of our research.

Several clinical and in vitro studies utilizing the model of freshly isolated peripheral blood mononuclear cells (PBMC) have been performed, and more than 50 papers have been published in 2015 and 2016 in a worldwide collaboration with different research groups. The reference given below refers to a review article, in which the general concept of this work can be deduced and detailed references can be extracted (Strasser B, Gostner JM, Fuchs D. Mood, food, and cognition: role of tryptophan and serotonin. *Curr Opin Clin Nutr Metab Care* 2016;19:55-61).

Alkylglycerol Monooxygenase: A Novel Ether-Lipid Cleaving Enzyme

Katrin Watschinger, Gabriele Werner-Felmayer, Georg Golderer and Ernst R. Werner

Built on almost forty years of pteridine research in this institute, the focus of our research is directed towards ether lipid metabolism. The degradation of ether lipids requires alkylglycerol monooxygenase, a tetrahydrobiopterin dependent enzyme. Tetrahydrobiopterin, a cofactor, is structurally related to the vitamins folic acid and riboflavin, but is synthesized in both the animal and human body. It is needed in five specific hydroxylation reactions; including the conversion of phenylalanine to tyrosine by phenylalanine hydroxylase. This conversion is the key step in the degradation of the essential amino acid

phenylalanine. Tetrahydrobiopterin is currently used to treat phenylketonuria, a rare inherited disease in humans that affects the phenylalanine hydroxylase.

Alkylglycerol monooxygenase is an especially labile integral membrane protein. In 2010, forty-six years after it was first described, we managed to assign a sequence to this enzyme; this enabled us to manipulate its expression in cultured macrophage-like cells. We were able to show that the knockdown of alkylglycerol monooxygenase had a profound impact on the lipidome of these cells (Figure 2). In addition, manipulation of tetrahydrobiopterin biosynthesis led to corresponding changes in the lipidome. For the first time these findings were able to constitute a functional connection of tetrahydrobiopterin biosynthesis to lipid metabolism in an intact cell.

In collaboration with research groups located in San Diego (USA), Oxford (UK), and Bergen (Norway), we investigated the role of alkylglycerol monooxygenase in *Caenorhabditis elegans*, a worm that is widely used as a model organism. We found that impairment of tetrahydrobiopterin synthesis in these animals led to a weakening of their cuticle. This is a result of impairing the alkylglycerol monooxygenase, and not of other tetrahydrobiopterin-dependent reactions. Interestingly enough, alkylglycerol monooxygenase was functionally associated with the susceptibility of these animals to bacterial infections.

Bioethics

Gabriele Werner-Felmayer

Current work focuses on epistemology, culture and ethical dimensions in biomedicine. It is inspired by interdisciplinary dialogue with colleagues

from philosophy, social and political sciences, law, economics and health management. Main topics of research are new technologies in the context of assisted reproductive technologies, third party cross-border reproductive care and its international regulation, unintended traumatization of patients in the context of medicalised reproduction, and prevailing deterministic views in the dynamic field of genetics/genomics, PhD projects deal with the ethics of reprogenetics in developing countries and with the definition of "race" in pharmacogenomics.

Selected Publications

The neurofibromin recruitment factor Spred1 binds to the GAP related domain without affecting Ras inactivation
Dunzendorfer-Matt, Theresia, Mercado, Ellen L., Maly, Karl, McCormick, Frank, Scheffzek, Klaus,
PROCEEDINGS OF THE NATIONAL ACADEMY OF SCIENCES OF THE UNITED STATES OF AMERICA: 2016; 113: S. 7497-7502

Mood, food, and cognition: role of tryptophan and serotonin
Strasser, Barbara, Gostner, Johanna M., Fuchs, Dietmar,
CURRENT OPINION IN CLINICAL NUTRITION AND METABOLIC CARE: 2016; 19: S. 55-61

Effects of Exhaustive Aerobic Exercise on Tryptophan-Kynurenine Metabolism in Trained Athletes
Strasser, Barbara, Geiger, Daniela, Schauer, Markus, Gatterer, Hannes, Burtscher, Martin, Fuchs, Dietmar,
PLOS ONE: 2016; 11: S. e0153617

Tetrahydrobiopterin and alkylglycerol monooxygenase substantially alter the murine macrophage lipidome
Watschinger, Katrin, Keller, Markus A., McNeill, Eileen, Alam, Mohammad T., Lai, Steven, Sailer, Sabrina, Rauch, Veronika, Patel, Jyoti, Hermetter, Albin, Golderer, Georg, Geley, Stephan, Werner-Felmayer, Gabriele, Plumb, Robert S., Astarita, Giuseppe, Ralser, Markus, Channon, Keith M., Werner, Ernst R.,
PROCEEDINGS OF THE NATIONAL ACADEMY OF SCIENCES OF THE UNITED STATES OF AMERICA: 2015; 112: S. 2431-2436

Selected Funding

- Structure of the neurofibromatosis type 1 protein, Austrian Science Fund (FWF), Klaus Scheffzek
- Alkylglycerol monooxygenase in *Dictyostelium discoideum*, Austrian Science Fund (FWF), Ernst R. Werner
- Closing the crucial genetic gap in plasmalogen biosynthesis, Austrian Science Fund (FWF), Ernst R. Werner

Collaborations

- Luciel Capuron, University of Bordeaux, France
- Keith Channon, Jonathan Hodgkin, University of Oxford, United Kingdom
- Pidder Jansen-Dürr, Leopold Franzens University, Innsbruck, Austria
- Frank McCormick, University of California San Francisco (UCSF), San Francisco, USA
- Andreas von Deimling, University Heidelberg, Heidelberg, Germany
- Magnus Gisslen, Lars Hagberg, Östra University Hospital, Gothenburg, Sweden
- Harald Mangge, Eva Reininghaus, Medizinische Universität Graz, Austria
- Teo T Postolache, University of Baltimore, MD, USA
- Richard W Price, Institut of Neurology, San Francisco General Hospital, UCSF, USA
- Markus Ralser, University of Cambridge, United Kingdom
- Thomas Rausch, University Heidelberg, Heidelberg Germany
- Barbara Prainsack, Kings College London; UK
- Silke Schickfanz, University Medicine Goettingen; Germany
- International Network of the UNESCO Chair in Bioethics, Haifa, Israel

Cell Biology



Head of Division:
Univ.-Prof. Dr. Lukas A. Huber

Contact:
Biocenter, Innrain 80-82
6020 Innsbruck

Lukas.A.Huber@i-med.ac.at
Phone: +43 512 9003 70170
Fax: +43 512 9003 73100
www.i-med.ac.at/cellbio

Research Branch (ÖSTAT Classification)

106013, 106023, 106037,
106041, 301904

Research Focus/Keywords

- Signal Transduction and Proteomics
- Cell Differentiation
- Membrane Traffic and Signalling

General Facts

Our division studies molecular mechanisms that determine cellular function and organization. To address these fundamental questions we use a combination of genetic model systems (yeast, mouse and human cells), microscopy, and quantitative proteomics. We provide an international and dynamic research environment for Master and PhD students and Postdocs. We are embedded in the international PhD program MCBO (Molecular Cell Biology and Oncology), coordinate several EU projects and have numerous national and international collaborations with academic partners and biotech companies.

Research

Three research groups are currently active at the Division of Cell Biology:

The Huber Lab:

Signal Transduction and Proteomics

This lab focusses on the role of scaffold proteins that are in spatial and temporal control of signal transduction. In addition, our group addresses the interaction between signalling and intracellular trafficking, both in the endocytic as well as the secretory pathways.

The LAMTOR Complex -The Crossroad between Signal Transduction and Endosomal Biogenesis

Over the last two decades we have shown that the LAMTOR complex (late endosomal/lysosomal adaptor, MAPK and MTOR activator) is recruited to the membrane of late endocytic compartments, where it can actively influence MAPK, mTORC signalling, and endosomal trafficking. On the organismal level, the LAMTOR is involved in numerous biological processes including immunity, early embryogenesis, tissue homeostasis, cellular proliferation, and migration (Wunderlich *et al.*, J Cell Biol 2001; Teis *et al.* Dev Cell 2002; Kurzbauer *et al.*, PNAS 2004; Teis *et al.*, JCB 2006; Bohn *et al.*, Nature Med 2007; Sancak *et al.*, Cell 2010; Bar-Peled *et al.*, Cell 2012; Takahashi *et al.*, Biochemical and biophysical research 2012.; Schiefermeier *et al.*, JCB 2014; Scheffler *et al.*, Nature comm. 2014) To dissect how LAMTOR functions we have performed an interaction screen using TAP-MS (Tandem Affinity Purification, coupled to Mass Spectrometry). The LAMTOR core interactome includes LAMTOR1-5 proteins-the RAG GTPases (that mediate the translocation of mTORC1 to endosomes/lysosomes), the regulatory-associated protein of mTOR Raptor, subunits of the vacuolar H⁺-ATPase, and a lysosomal solute carrier (SLC38A9). We could show that SLC38A9 is an integral component of the amino acid-sensing machinery that controls the activation of mTORC1 (Rebsamen *et al.*, Nature, 2015, Figure 1). We are currently analyzing novel LAMTOR interactions partner and how they are linked to signalling and endosomal biogenesis.

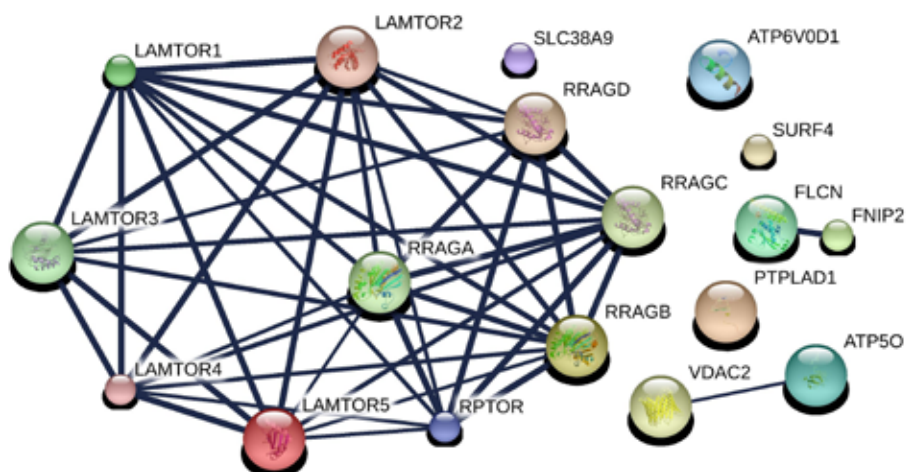

Fig. 1: Core interactome of the LAMTOR complex.

Microvillus Inclusion Disease - Intracellular Trafficking and Epithelial Polarity

Microvillus inclusion disease (MVID) is an autosomal recessive enteropathy and frequently causes lethal diarrhea in the first few weeks of life. Hallmark characteristics of MVID are a lack of microvilli on the surface of villous enterocytes, the presence of intracellular microvillus inclusions, and cytoplasmic accumulation of periodic acid-Schiff (PAS)-positive vesicles in enterocytes.

Together with our local collaborators (Pediatrics I and the Division of Histology and Embryology), we were the first to identify mutations in the unconventional type Vb myosin motor protein (MYO5b), in a cohort of nine MVID patients (Mueller *et al.*, Nature Genetics 2008). In a follow-up study 15 novel nonsense and missense mutations in MYO5B could be identified in 11 independent MVID patients (Ruemmele *et al.*, Human Mutation 2010). Further investigations focused on the role of Myosin Vb and its relationship to Rab Small GTPases in establishing correct epithelial polarity (Thoeni *et al.*, Traffic 2014) (Vogel *et al.*, Journal of Cell Biology 2015).

Recently, we identified new mutations in the STX3 gene in patients that tested negative for mutations in MYO5B; the STX3 gene was identified as the cause of a variant of MVID. (Wiegerinck *et al.*, Gastroenterology 2014). Syntaxin 3 is an apical

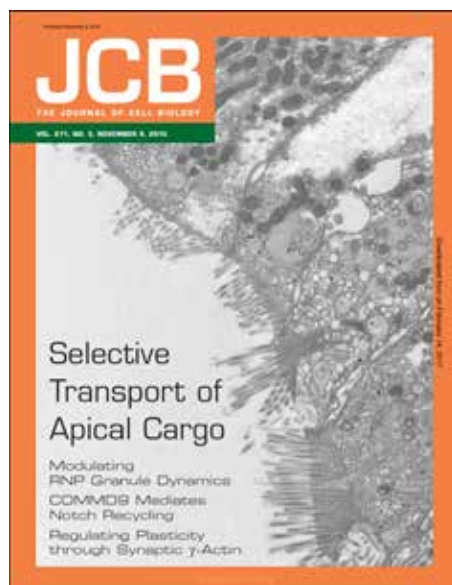

Fig. 2: Cover page of the Journal of Cell Biology (Vogel *et al.*, Journal of Cell Biology 2015). displaying the MVID-CaCo2 model cell line. Disturbed microvilli formation and prominent subapical secretory granules are visible.

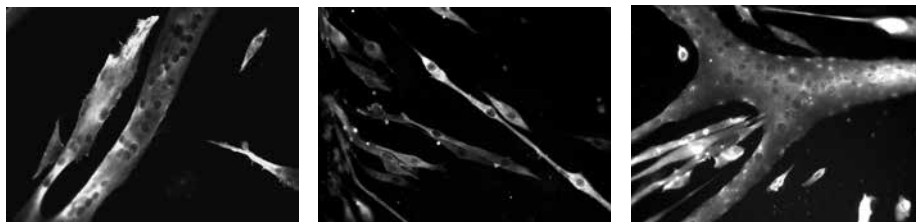

Fig. 3: Muscle satellite cells grown under differentiation conditions. Immunofluorescence microscopy images depict (from left to right): TIS7 wild type differentiated myoblasts, not fusing TIS7 knockout mouse-derived myoblasts and same cells following the TIS7 over-expression.

t-SNARE protein pivotal for polarized apical exocytosis and secretion in epithelial cells. Using cellular models for epithelial/enterocyte polarity and genome-editing technologies we identify intracellular networks, that ensure correct polarized intracellular traffic and thereby maintain proper epithelial polarity, are researched.

The Vietor Lab: Cell Differentiation

The interplay between cell proliferation and differentiation controls development and regeneration and therefore represents a possible therapeutic target. Based on our studies, we predict that the transcriptional co-regulator TPA-inducible sequence 7 (TIS7) is an important regulator of cellular regeneration events. TIS7 is differentially expressed in several different polarized cell types and its expression can be induced by growth factors and TPA.

We have shown that TIS7 interacts with the SIN3 complex and regulates transcription in an HDAC-dependent manner (Vietor *et al.*, EMBO J 2002). In the promoter region of TIS7-regulated downstream target genes we have identified a common regulatory motif C/EBPalpha-Sp1 transcription factor "module" (Wick *et al.*, J Mol Biol 2004). Furthermore, TIS7 has the ability to inhibit the Wnt signalling in an HDAC-dependent manner. TIS7 expression increases during the process of tissue regeneration following a challenge like muscle injury or intestinal resection. Our previous studies have shown that in TIS7 deficient mice the expression of myogenic regulatory proteins is deregulated and the differentiation and fusion potential of muscle satellite cells is impaired (Vadivelu *et al.*, Mol Cell Biol 2004).

Using TIS7 knockout mice generated in our lab, the research group of our collaborators surrounding Prof. Chris Karp at the Cincinnati College of Medicine, USA identified TIS7 to be the main modifier of the severity of lung disease in cystic fibrosis

(CF). Lung disease is the major cause of morbidity and mortality in cystic fibrosis, an autosomal recessive disease caused by mutations in CFTR. In CF chronic infections and dysregulated neutrophilic inflammation lead to a progressive destruction of the airways. In contrast to macrophages neutrophils of TIS7-deficient mice showed decreased neutrophil effector functionality. *In vivo* TIS7 deficiency caused delayed bacterial clearance from the airways, but also exhibited fewer symptoms of inflammation and lung disease. In humans, TIS7 polymorphisms are predominately associated with variations in neutrophil effector function; this data indicates that TIS7 modulates the pathogenesis of cystic fibrosis lung disease by regulating neutrophil effector function. These findings were published in Nature in collaboration with the Cincinnati College of Medicine (Gu *et al.*, Nature 2009).

In our recent paper we identified the protein ICln as the specific, novel protein downstream of TIS7 controlling the process of myogenesis. We have shown that the complex TIS7 / ICln epigenetically regulates expression of the muscle regulatory gene myoD in a protein methyl transferase activity-dependent manner. Thereby we have identified



Fig. 4: Fused TIS7 wt skeletal muscle cells grown under differentiation conditions in culture. Raster electron scanning micrograph.

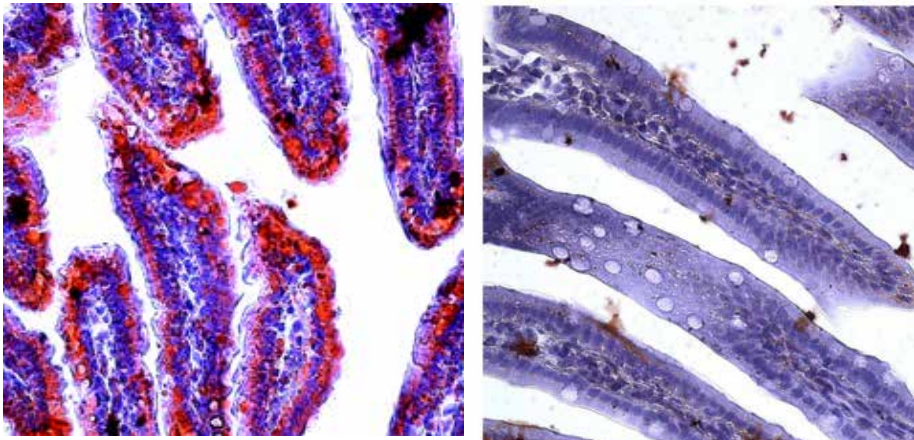

Fig. 5: Lack of fat vacuoles in the jejunum of TIS7 SKMc15 double knockout mice (right). Oil red oil staining; magnification 40x.

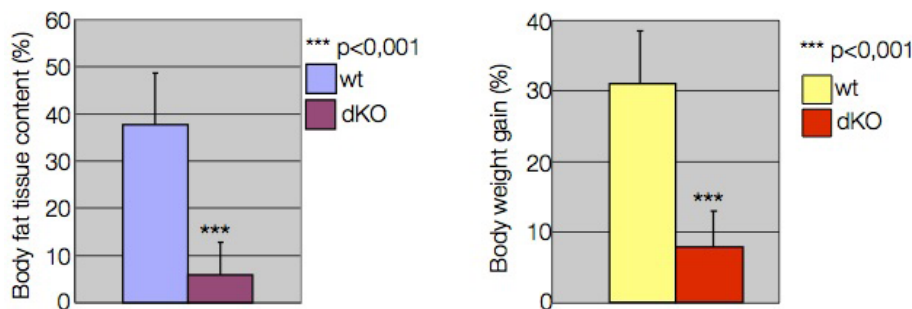

Fig. 6: TIS7 SKMc15 double knockout mice are significantly leaner. 6 months old male mice; n= 6; Chow diet; (left). TIS7 SKMc15 double knockout mice gain significantly less weight upon feeding with high fat diet. 11 weeks male mice; n= 11; 3 weeks high fat diet; (right).

a novel mechanism in which TIS7-specifically controls skeletal muscle differentiation. In particular, in this novel pathway ICl α regulates MyoD expression via its interaction with the methyl transferase PRMT5 (Lammirato *et al.*, BMC Biology 2016). SKMc15 is a protein which is highly homologous to TIS7. Our laboratory generated SKMc15 single as well as TIS7 SKMc15 double knockout mice, to study their role during embryonic development and in adult mice. TIS7 SKMc15 double knockout mice are significantly smaller and leaner. Surprisingly, they never grown fat and are fully resistant against weight gain upon feeding with the high fat-diet. We are currently characterizing the underlying molecular mechanism.

Teis Lab:

Membrane Traffic and Signalling.

Cell growth and survival requires the selective degradation of cellular components; Defects in cellular degradation systems corrupt cellular homeostasis, results in cellular protein aggregation which in re-

turn causes of a wide variety of diseases ranging from cancer to neurodegeneration. How different cellular degradation systems work together is not understood.

The Teis Lab focuses on the molecular mechanisms that are required for the selective degradation of integral membrane proteins. A key step in this process occurs on endosomes, where the endosomal complexes required for transport (ESCRTs) bind to and sort ubiquitinated membrane proteins via the multivesicular body (MVB) pathway into the lumen of lysosomes for degradation (Figure 7). This process requires reverse membrane to bud intraluminal MVB vesicles (ILVs) away from the cytoplasm and into the lumen of MVBs (Figure 8A). We showed that the assembly of the ESCRT-III complex and the coordinated binding of the AAA-ATPase Vps4 is essential for this process (Adell *et al.* JCB 2014). Topologically similar ESCRT dependent membrane budding reactions are required in distinct

cellular processes, including: membrane scission at the end of cytokinesis, release of budding HIV from host cells, micro-vesicle formation at the plasma membrane, plasma membrane repair, quality control of nuclear pore complex assembly, and nuclear envelope reformation and sealing.

Cell growth and survival requires the selective degradation of cellular components; Defects in cellular degradation systems corrupt cellular homeostasis, results in cellular protein aggregation which in return causes of a wide variety of diseases ranging from cancer to neurodegeneration. How different cellular degradation systems work together is not understood.

The Teis Lab focuses on the molecular mechanisms that are required for the selective degradation of integral membrane proteins. A key step in this process occurs on endosomes, where the endosomal complexes required for transport (ESCRTs) bind to and sort ubiquitinated membrane proteins via the multivesicular body (MVB) pathway into the lumen of lysosomes for degradation (Figure 7). This process requires reverse membrane to bud intraluminal MVB vesicles (ILVs) away from the cytoplasm and into the lumen of MVBs (Figure 8A). We showed that the assembly of the ESCRT-III complex and the coordinated binding of the AAA-ATPase Vps4 is essential for this process (Adell *et al.* JCB 2014). Topologically similar ESCRT dependent membrane budding reactions are required in distinct cellular processes, including: membrane scission at the end of cytokinesis, release of budding HIV from host cells, micro-vesicle formation at the plasma membrane, plasma membrane repair, quality control of nuclear pore complex assembly, and nuclear envelope reformation and sealing. How the ESCRT machinery catalyses these membrane remodeling reactions remains unclear.

Thus one key question in our lab is to understand how the ESCRT machinery sculpts membranes (Figure 8B). Furthermore, we would like to understand how the ESCRT dependent degradation of membrane proteins interacts with autophagy and proteasomal degradation pathways and how their coordinate function contributes to cell growth and survival, given the key role of ESCRTs during developmental and disease. To address these questions yeast was determined as the best suited model system, because it combines genetics with quantitative proteomics, biochemical methods, and different imaging approach-

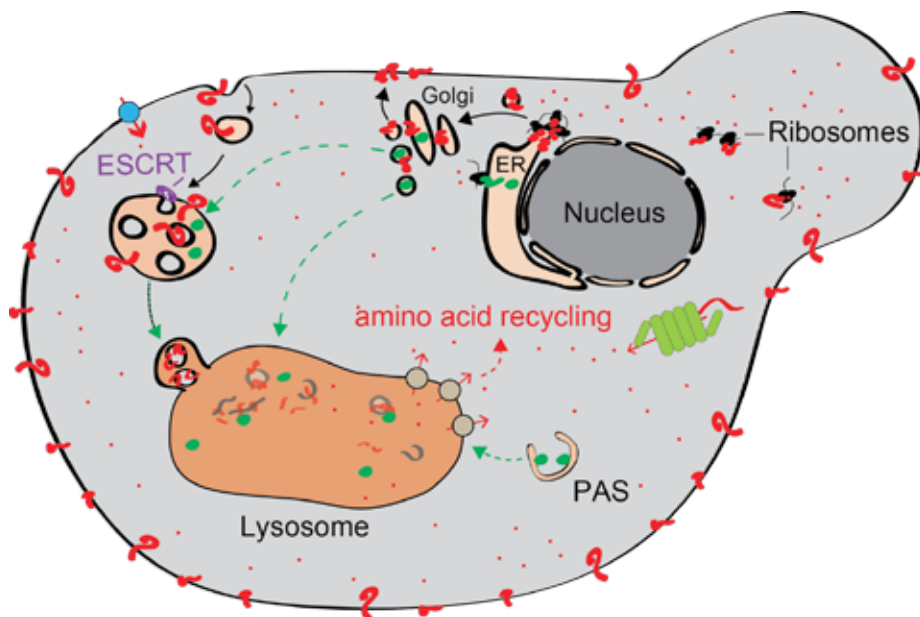

Fig. 7: Schematic Representation of the MVB Pathway.

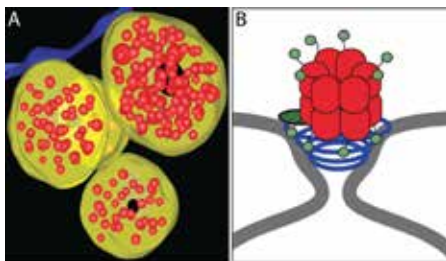

Fig. 8: (A) 3D-Modeling of cryo-fixed cells. MVBs (yellow), Intraluminal MVB vesicles (ILVs) (red), vacuole (blue). (B) Model of ESCRT-III and Vps4 during ILV neck constriction.

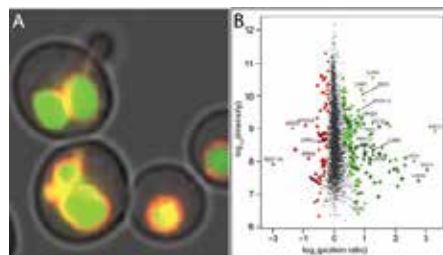

Fig. 9: (A) Fluorescence microscopy of living yeast, vacuole (red), GFP-CPS (green). (B) Graphical representation of quantitative proteomics.

es (Figure 9A, B). Our results suggest that the MVB pathway and autophagy function together to ensure cell survival during nutrient limitation (Mueller *et al.* eLife 2015).

Selected Publications

The coordinated action of the MVB pathway and autophagy ensures cell survival during starvation
Mueller, Martin, Schmidt, Oliver, Angelova, Mihaela, Faserl, Klaus, Weys, Sabine, Kremser, Leopold, Pfaffenwimmer, Thaddaeus, Dalik, Thomas, Kraft, Claudine, Trajanoski, Zlatko, Lindner, Herbert, Teis, David,
ELIFE: 2015; 4: S. e07736

SLC38A9 is a component of the lysosomal amino acid sensing machinery that controls mTORC1
Rebsamen, Manuele, Pochini, Lorena, Stasyk, Taras, de Araujo, Mariana E. G., Galluccio, Michele, Kandasamy, Richard K., Snijder, Berend, Fauster, Astrid, Rudashevskaya, Elena L., Bruckner, Manuela, Scorzoni, Stefania, Filippek, Przemyslaw A., Huber, Kilian V. M., Bigenzahn, Johannes W., Heinz, Leonhard X., Kraft, Claudine, Bennett, Keiryn L., Indiveri, Cesare, Huber, Lukas A., Superti-Furga, Giulio,
NATURE: 2015; 519: S. 477+

Lysosomal signaling in control of degradation pathways
Huber, Lukas A., Teis, David,
CURRENT OPINION IN CELL BIOLOGY: 2016; 39: S. 8-14

Asymmetric arginine dimethylation of RelA provides a repressive mark to modulate TNF alpha/NF-kappa B response
Reintjes, Anja, Fuchs, Julian E., Kremser, Leopold, Lindner, Herbert H., Liedl, Klaus R., Huber, Lukas A., Valovka, Taras,
PROCEEDINGS OF THE NATIONAL ACADEMY OF SCIENCES OF THE UNITED STATES OF AMERICA: 2016; 113: S. 4326-4331

Cargo-selective apical exocytosis in epithelial cells is conducted by Myo5B, Slp4a, Vamp7, and Syntaxin 3
Vogel, Georg F., Klee, Katharina M. C., Janecke, Andreas R., Mueller, Thomas, Hess, Michael W., Huber, Lukas A.,
JOURNAL OF CELL BIOLOGY: 2015; 211: S. 587-604

Selected Funding

- FWF: FWF P 30263 (DT); FWF P 29583 (DT), Special research program SFB021 (LAH, DT), PhD Program MCBO (LAH, DT), START-Prize (DT), P18531-B12 (TV), P22350-B12 (IV), P26682-B21 (LAH)
- EU: FP7 Optatio (LAH), HFSP Career Development Award (DT)

Genomics and RNomics



Head of Division:
Univ.-Prof. Dr. Alexander Hüttenhofer

Contact:
Biocenter, Innrain 80-82
6020 Innsbruck

Alexander.Huettenhofer@i-med.ac.at
Phone: +43 512 9003 70250
Fax: +43 512 9003 73100
www.rnomics.at

Research Branch (ÖSTAT Classification)

106002, 106014, 106023

Keywords

Non-coding RNAs; RNPs, RNA sequencing (RNAseq), ribosome, translation, termination

Research Focus

In cells from all organisms two different types of RNA molecules are found: messenger RNAs (mRNAs), and so-called “non-protein-coding RNAs” (ncRNAs). Many known ncRNAs, such as microRNAs, are involved in the regulation of gene expression. Our group works on the identification of regulatory non-coding RNAs in various model organisms. In particular, we are interested in the identification of ncRNAs regulating neuronal development and in the identification of ncRNAs involved in CNS diseases.

General Facts

Our group works on the identification of regulatory non-coding RNAs (ncRNAs) in various model organisms for which we have coined the term “Experimental RNomics”. We have characterized the entire small ncRNA tran-

scriptome, involved in the differentiation of mouse embryonic stem (ES) cells into neural cells, by generating specialized ribonucleo-protein particle (RNP)-derived cDNA libraries. By high-throughput sequencing and transcriptional profiling we identified several novel miRNAs to be involved in ES cell differentiation, as well as seven small nucleolar RNAs. Based on these findings, we have generated a custom microarray chip, covering novel ncRNAs from ES cell differentiation. Another research interest is the regulation of ribosomal translation by natural and non-natural modifications introduced into functionally important regions of the ribosome as well as incorporated into the coding sequences of the mRNA to investigate decoding and termination.

Research

Role of ncRNAs in Neurodevelopmental Disorders

Alexander Hüttenhofer

Small non-protein-coding RNAs (ncRNAs) play important roles in the regulation of gene expression and have been implicated in a number of diseases of the central nervous system (CNS). Thereby, a well-characterized class of small ncRNAs is represented by miRNAs, for which numerous commercial tools (e.g. qPCR panels, micro arrays) have been developed to screen

their differential expression in human patients as well as animal disease models. Indeed, by these approaches several miRNAs have been implicated in the etiology of neurological diseases. In addition to miRNAs, however, there is a large number of short ncRNA species (sized about 18 - 200 nt), which are either poorly characterized or which belong to other known classes of ncRNAs (i.e. snRNAs, snoRNAs, or piRNAs) for which no high-throughput tools have been available to perform expression profiling. Thus in this project, which is part of the SFB F44 “Cell signaling in chronic CNS disorders”, we developed an unbiased and comprehensive microarray platform to profile the expression of thousands of these novel ncRNA species from mouse brain tissues. To date, we have applied this customized microarray, designated as neuro-ncRNA chip, to selected mouse models for LTCC activity and CNS disorders e.g. Alzheimer’s disease, Multiple-system atrophy. Thereby we discovered more than 100 novel ncRNA candidates whose expression was found to be de-regulated in comparison to wild type controls. In the Alzheimer mouse model, we identified two snoRNAs, whose expression was deregulated prior to amyloid plaque formation. Interestingly, presence of snoRNAs could be detected in cerebral spine fluid samples in humans, thus potentially serving

Protein-coding and non-protein-coding RNAs

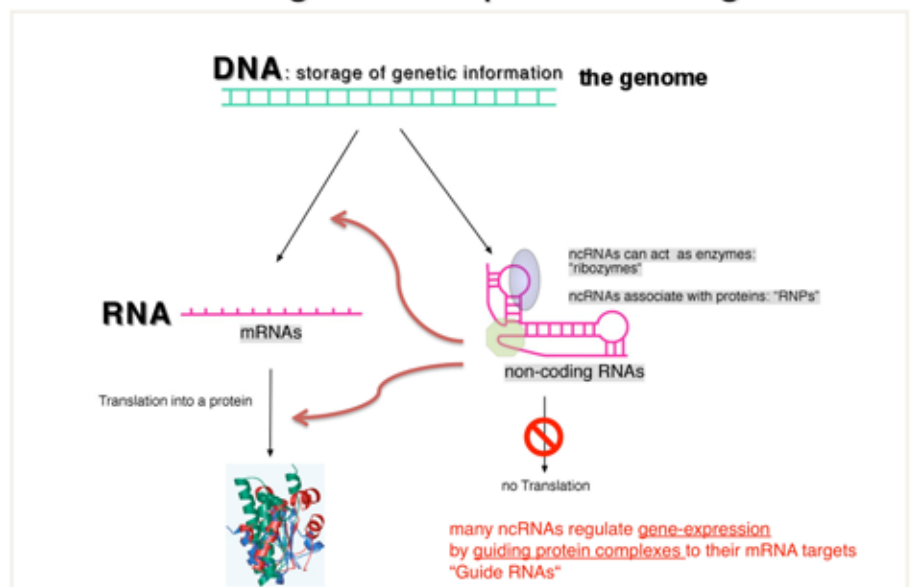

Fig. 1: Two classes of RNA species are transcribed from genomes of all organisms: messenger RNAs (mRNAs) and non-coding RNAs (ncRNAs); ncRNAs are not translated into proteins and many of them are able to regulate gene expression by regulating transcription or translation of mRNAs and thus act a genetic switches.

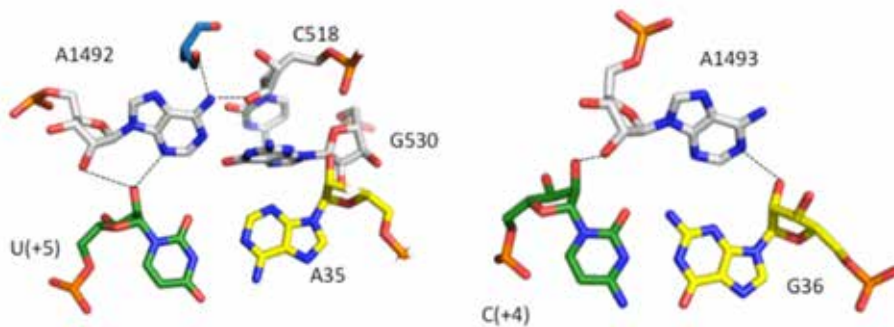

Fig. 2: Non-natural modifications can be site-specifically incorporated into the 16S rRNA, to determine their impact on decoding.

as early diagnostic makers for Alzheimer's disease. In addition, we could show the applicability of our customized microarray to human post-mortem brain tissue of Alzheimer's disease patients and healthy individuals. We identified 51 differentially expressed ncRNAs by expression profiling of post mortem human brain samples of Alzheimer's disease patients with healthy controls and could also show that 60% of the ncRNAs which are present on our customized microarray exhibit expression signals above background in human tissue. In addition, we focused on the biochemical characterization of the novel ncRNA candidates by *in situ* hybridization to define cellular as well as subcellular localizations of ncRNAs.

Identification of ncRNA Patterns as Biomarkers for Pain and Inter-Individual Variations

Alexander Hüttenhofer

This project is part of the EU Project "ncRNA-Pain" and aims to the identification of pain predisposing ncRNA patterns as biomarkers for pain and inter-individual varia-

tion. This aim will be achieved by identifying altered expression patterns of ncRNAs/miRs in painful vs. non-painful diabetic neuropathies (dPNP), in complex regional pain syndrome (CRPS) after trauma vs. patients after trauma without CRPS and in addition in painful and non-painful nerve lesions (NL). An initial quality check showed that ncRNAs can robustly be measured from white blood cells and from serum. A first analysis in white blood cells and serum of n= 10 patients with painful and non-painful dPNP revealed that ncRNA profiles can almost perfectly differentiate between these two subgroups.

Modified mRNA Nucleotides Regulate Translation Processes

Matthias Erlacher

RNA modifications can be found in every organism in all three domains of life. Although more than 100 different types were identified, mRNAs were thought to be only rarely modified. Whereas N6-methyladenosine (m6A) was described already 4 decades ago and shown to be the most abundant modification in eukaryotic mRNAs, the presence of

5-methylcytosine (m5C) and pseudouridine (Ψ) in this class of RNA was only identified recently. The influence of any of these modifications on ribosomal translation is largely unknown and has been mainly a matter of speculation. Employing a cell free translation system, we systematically investigate the effects of single modified mRNA residues on translation fidelity and efficiency.

Modified mRNA Nucleotides as Tool to Investigate Translation Processes

Matthias Erlacher

Whereas mRNA modifications are a potential tool to regulate translation processes, we aim to employ a broad spectrum of RNA base modifications to get a deeper insight into mechanistic details of the decoding process during protein synthesis. Besides, we establish various tools to also address translation initiation and termination employing RNA derivatives. The aim is to reveal molecular details of translation processes at a so far unmet detail.

Selected Publications

Changes in the miRNA-mRNA Regulatory Network Precede Motor Symptoms in a Mouse Model of Multiple System Atrophy: Clinical Implications

Schaffner, Simon, Khurana, Rimpì, Refolo, Violetta, Venezia, Serena, Sturm, Edith, Piatti, Paolo, Hechenberger, Clara, Hackl, Hubert, Kessler, Roman, Willi, Michaela, Gstir, Ronald, Krogsdam, Anne, Lusser, Alexandra, Poewe, Werner, Wenning, Gregor K., Huettenhofer, Alexander, Stefanova, Nadia, PLOS ONE: 2016; 11: S. e0150705

Nucleotide modifications within bacterial messenger RNAs regulate their translation and are able to rewire the genetic code

Hoernes, Thomas Philipp, Clementi, Nina, Faserl, Klaus, Glasner, Heidelinde, Breuker, Kathrin, Lindner, Herbert, Huettenhofer, Alexander, Erlacher, Matthias David, NUCLEIC ACIDS RESEARCH: 2016; 44: S. 852-862

mRNA modifications: Dynamic regulators of gene expression?

Hoernes, Thomas Philipp, Huettenhofer, Alexander, Erlacher, Matthias David, RNA BIOLOGY: 2016; 13: S. 760-765

Impact of the Chromatin Remodeling Factor CHD1 on Gut Microbiome Composition of Drosophila melanogaster

Sebald, Johanna, Willi, Michaela, Schoberleitner, Ines, Krogsdam, Anne, Orth-Hoeller, Dorothea, Trajanoski, Zlatko, Lusser, Alexandra, PLOS ONE: 2016; 11: S. e0153476

Expression of the vault RNA protects cells from undergoing apoptosis

Amort, Melanie, Nachbauer, Birgit, Tuzlak, Selma, Kieser, Arnd, Schepers, Aloys, Villunger, Andreas, Polacek, Norbert, NATURE COMMUNICATIONS: 2015; 6: S. 7030

Selected Funding

SFB 044; 7th framework EU: SysKid; 7th framework EU: ncRNA-Pain; FWF P 28494-BBL

Collaborations

- Joerg Vogel, MPI Berlin Germany
- Ralph Bock, MPI Potsdam, Germany
- Jürgen Brosius, University of Münster, Germany
- Norbert Polacek, University of Bern, Switzerland
- Eric Westhof, Université de Strasbourg, France
- Simpson Joseph, University of California, USA

Core Facilities

- Genome Seq Core
- Affymetrix core facility

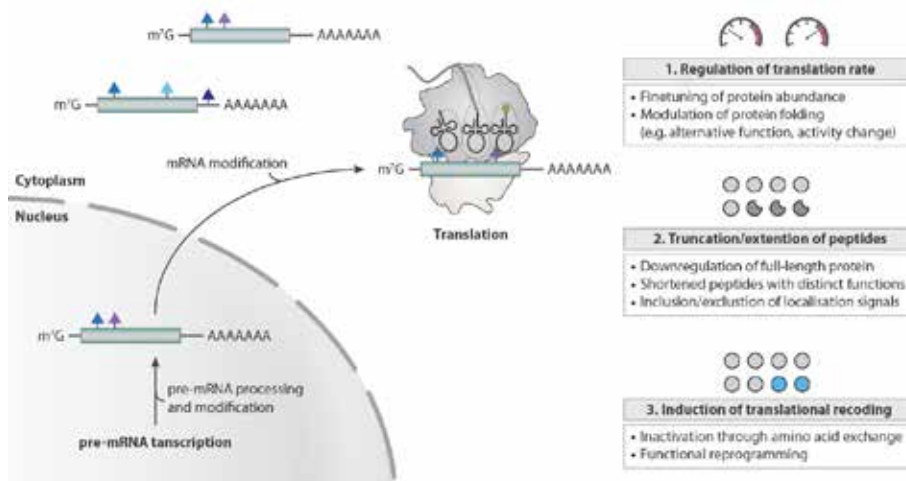

Fig. 3: Modifications (triangles) within coding sequences of mRNAs can regulate protein synthesis.

Molecular Biology



Head of Division:
Univ.-Prof. Dr. Peter Loidl

Contact:
Biocenter, Innrain 80-82
6020 Innsbruck

Peter.Loidl@i-med.ac.at
Phone: +43 512 9003 70201
Fax: +43 512 9003 73100
www.i-med.ac.at/molbio

Research Branch (ÖSTAT Classification)

106023, 106022, 106024,
301114, 303020

Keywords

Chromatin and epigenetics, histone modifying enzymes, ATP-dependent chromatin remodeling, RNA cytosine methylation, filamentous fungi, iron metabolism, fungal infection, antifungal drugs, bioactive fungal products, siderophores, lipocalins, antimicrobial proteins, innate immunity and allergy

Research Focus

Physiology, Gene Regulation and Secondary Metabolism in Filamentous Fungi

- Iron metabolism in filamentous fungi: links to human disease
- Functions of histone modifying enzymes in gene regulation, fungal physiology and as targets for novel antifungal substances
- Structure and mechanism of action and applicability of antimicrobial peptides/proteins secreted by filamentous fungi

Lipocalins and their Involvement in Innate Immunity and Allergy

Epigenetics and Epitranscriptomics

- Biological roles of ATP-dependent chromatin remodeling enzymes
- RNA methylation and its impact on RNA metabolism
- Posttranslational acetylation of regulatory non-histone proteins

General Facts

The Division of Molecular Biology is home to six independent research groups, whose scientific interests range from the investigation of diverse aspects of filamentous fungi physiology and metabolism, to the study of secretory lipocalins, to research into the nature and significance of chromatin remodeling and epitranscriptomic mechanisms.

A common long-term goal of all groups is to explore the relationship of the diverse processes mentioned above with diagnostics and treatment of human disease. In this regard, the groups of Hubertus Haas, Gerald Brosch/Stefan Graessle, and Florentine Marx-Ladurner strive to elucidate pathogenicity determinants and potential drug targets of filamentous fungi. Moreover, they examine the regulatory mechanisms of secondary metabolites (e.g. penicillin),

secretory proteins and components, such as antimicrobial proteins and iron-chelating siderophores, of which both have potential in antifungal therapy and diagnosis. The Redl group investigates the mechanism of action of lipocalins, which are secretory scavenger proteins. Thus, lipocalins are important components of the innate immune system, yet they might also be involved in allergic reactions. The Lusser group conducts studies of fundamental gene regulatory mechanisms involving the remodeling of chromatin structure as well as posttranscriptional modification of RNAs. Finally, the Loidl group investigates histone modifying enzymes, in particular the role of acetylation of regulatory non-histone proteins. Together, the researchers make use of a wide array of experimental model systems including filamentous fungi (*Aspergillus*, *Penicillium*, *Acremonium*, *Neurospora*), the fruit fly *Drosophila melanogaster*, and mammalian models such as embryonic stem cells and somatic cell lines as well as knock-out mice. Continuous third party funding (e.g. FWF) of all research groups, the participation of members of the division in several intra- and extramural network activities such as the FWF-funded PhD programs "HOROS" and "MCBO", the Infect-ERA network "AspMetNet" and the D-A-CH network on iron sensing in filamentous fungi or the attraction of postdoctoral fellows funded by external fellowships attests to the high standard of research quality. Staff of the Division of Molecular Biology also contribute substantially to the curricular teaching activities at the MUI. Notably, the division chair, Peter Loidl, is Vice Rector for Academic Affairs at the university. He also took a leading role in the establishment of the two new study directions in Molecular Medicine (Bachelor and Master studies) and he is the coordinator of the Molecular Medicine Bachelor program. Gerald Brosch is coordinator and Alexandra Lusser is deputy coordinator of the PhD Program "Regulation of Gene Expression", and Bernhard Redl is coordinator of the Molecular Medicine Master program. Beyond that, all group leaders teach lectures, seminars and practical courses in the curricula of human medicine, dental medicine, molecular medicine (bachelor and master) and of the PhD curriculum.

Research

Physiology, Gene Regulation and Secondary Metabolism in Filamentous Fungi

Gerald Brosch, Stefan Graessle, Hubertus Haas, Florentine Marx-Ladurner
Fungi affect the life of mankind in positive

and negative ways. On the one hand, fungi are major players in saprobic decomposition, they mutually interact with plants (mycorrhiza), serve as food source (mushrooms) or in food production (e.g., bread, cheese, alcohol), and produce widely used primary (e.g. citric acid) and secondary metabolites (e.g. penicillin). On the other hand, some fungi are pathogens of plants (e.g. *Fusarium* spp.) and animals (e.g. *Aspergillus fumigatus*), or spoil food by contamination or toxin production (e.g. aflatoxin). Therefore, fungi impact ecology, biotechnology, medicine, agriculture and food industry. The best-studied fungal organism is *Saccharomyces cerevisiae*. In several aspects, however, the physiology of this unicellular organism is not comparable to that of the more complex filamentous fungi (e.g. iron metabolism, light regulation, secondary metabolism). Three research groups in the Division of Molecular Biology address different aspects of filamentous fungal physiology ranging from iron metabolism and its significance for pathogenesis (Haas), to chromatin-linked mechanisms of gene expression control (Brosch/Graessle) and the nature and mechanisms of action of antimicrobial proteins produced

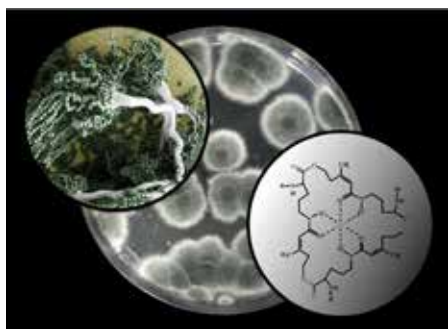

Fig. 1: Cover Figure of *Natural Product Reports* 31(10). "Fungal siderophore metabolism with a focus on *Aspergillus fumigatus*". Haas H. 2014.

by filamentous fungi (Marx-Ladurner).

Iron Metabolism in Filamentous Fungi: Links to Human Disease

Hubertus Haas

Our central research goal is to characterize fungal metabolism and to exploit this knowledge for both improvement of antifungal therapy and diagnosis of fungal infections as well as improvement of the biotechnological potential of fungi. The present research focuses on iron/siderophore metabolism of *Aspergilli*. *Aspergillus fumigatus* is a typical saprobic filamentous ascomycete but also the most common air-

borne fungal pathogen of humans. It causes allergic and invasive diseases depending on the immune status of the patient. Unsatisfying diagnostic and therapeutic possibilities are reflected in a high mortality rate. *A. fumigatus* and its low-pathogenic relative *Aspergillus nidulans* produce extracellular siderophores (triacetylfusarinine C) for iron acquisition and intracellular siderophores (ferricrocin) for storage and distribution of iron. Siderophore biosynthesis is regulated by two transcription factors, SreA and HapX. Siderophores are central components of the fungal metabolism as they affect germination, sexual and asexual reproduction, oxidative stress resistance and virulence. Lack of siderophore biosynthesis renders *A. fumigatus* apathogenic. Consequently, the siderophore system represents a novel attractive target for improvement of antifungal therapy and diagnosis of fungal infections.

Additional research topics include iron sensing, heme metabolism, noncoding RNAs, secondary metabolism (e.g. cephalosporin biosynthesis by *Acremonium chrysogenum*), identification of potential drug targets, diagnosis of fungal infections and improvement of molecular tools for the manipulation of fungi.

Major Achievements:

Identification and characterization of fungal iron-regulatory and iron-sensing mechanisms. Characterization of fungal iron uptake and storage, particularly the siderophore system.

Regulatory and structural links of iron homeostatic mechanisms and other metabolic pathways, e.g. pH regulation, ergosterol biosynthesis, hypoxia adaptation.

First-time *in vivo* PET-imaging of fungal infections using ⁶⁸Gallium-labelled siderophores

Future Goals:

Detailed characterization of the iron and heme homeostasis-maintaining mechanisms of filamentous fungi (in particular of *Aspergilli*) and applied medical and biotechnological exploitation of the gained knowledge.

Functions of Histone Modifying Enzymes in Gene Regulation and Fungal Physiology

Gerald Brosch and Stefan Graessle

In addition to distinct regulatory sequences in gene promoters, the readout of genetic information in eukaryotes is significantly controlled at the chromatin level. In addition to ATP-dependent chromatin remodeling and

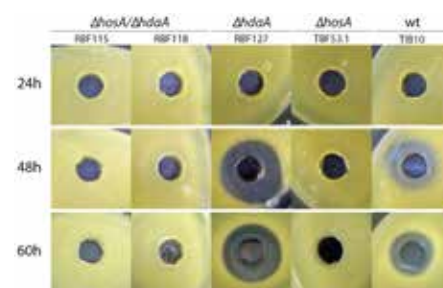

Fig. 2: Production of penicillin (PN) in different *Aspergillus* HDAC-mutants. A bacterial growth inhibition assay plate with *Kocuria rhizophila* as indicator organism was used to quantify PN in the medium of wild type (wt), $\Delta hdaA$, $\Delta hosA$, and two double mutant strains after 24h, 48h, and 60h of growth. The relative sizes of bacterial growth inhibition zones correspond to relative accumulation of PN in the culture medium of the fungus. Whereas the class 2 HDAC *HdaA* has a repressing effect, the class 1 enzyme *HosA* seems to be crucial for the production of PN in *Aspergillus nidulans*.

methylation of DNA on distinct cytidines, covalent posttranslational modifications of histones have profound structural and functional consequences for the transcription program of a cell. The main research focus of this lab lies on elucidating the functional impact of histone acetylation and histone/protein arginine methylation on fungal physiology. In particular we are interested in studying to what extent histone modifying activities are involved in fungal pathogenicity as well as to investigate their role in regulating secondary metabolite production.

To this end, the group has generated *Aspergillus* strains with individual or pairwise deletion of all protein arginine methyltransferase (PRMT) genes and of the class I histone deacetylases (HDACs) RpdA and HosA. Using these tools together with specifically engineered transgenes, their impact on viability and metabolism of the fungus was studied. Moreover, proteomic and transcriptomic analyses were performed to (i) characterize novel substrates and (ii) to investigate the contribution of HDACs and PRMTs to the regulation of secondary metabolism as well as to stress response genes.

Major Achievements:

Identification of a novel PRMT (RmtD) in filamentous fungi, which differs from other PRMTs in that it does not accept canonical substrates (histones, RNPs) but instead methylates three as yet unknown proteins. Identification and functional characteriza-

tion of two fungal-specific protein domains in the HDAC RpdA, which are essential for the viability of *Aspergillus* and thus might serve as targets for future antifungal therapy. Identification of the HDAC HosA as a major regulator of medically important secondary metabolites of filamentous fungi.

Future Goals:

Isolation and identification of novel targets of *Aspergillus* PRMTs. Elucidation of the biological role of RmtD. Development of antifungal strategies targeting the fungal-specific domains of RpdA. Identification of (novel) HDAC-regulated secondary metabolites (SM) of *Aspergilli* and elucidation of the control-mechanisms of the corresponding SM gene clusters via HosA and HDACs.

Structure, Mechanism of Action and Applicability of Antimicrobial Peptides/Proteins Secreted by Filamentous Fungi
Florentine Marx-Ladurner

Filamentous fungi secrete a wide range of different proteins into the external medium, which are used for diverse functions, such as nutrient assimilation, quorum sensing, host invasion and colonization, etc. Apart from some secreted enzymes, which have been developed for a variety of commercial uses (mainly for the fermentation industry), only few extracellular proteins are well characterized with respect to their function, such as pathogenicity or cell signalling factors. Our main scientific interest is to identify, isolate and further characterize the molecular, structural and functional level of novel extracellular proteins

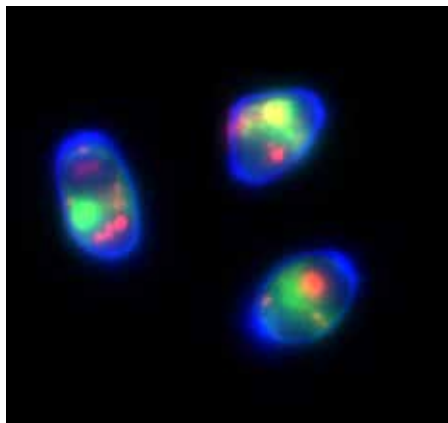

Fig. 3: Live-cell imaging of *Neurospora crassa* conidia exposed to BODIPY-labelled anti-fungal protein PAF (green, vacuoles) and co-stained with propidium iodide (red, nucleic acids) and calcofluor-white (blue, fungal cell wall).

with antimicrobial activity from *Penicillium chrysogenum*, *Aspergillus nidulans* and *Aspergillus fumigatus*. Antimicrobial proteins are promising candidates for the development of novel therapies applicable in medicine as well as in agriculture and in the food industry to prevent and treat microbial infections. Therefore, the detailed characterization of these proteins is of crucial importance and a prerequisite for the development of new therapeutic approaches and their successful application in the future.

Major Achievements:

Understanding the structure-function relation of antimicrobial proteins and first steps towards their biotechnological/medical application.

Future Goals:

Identification of molecular targets for the development of new therapeutic drugs. Rational design of antimicrobial proteins and peptides with improved efficiency and specificity. Characterization of additional cellular functions of antifungal proteins apart from their antimicrobial activity.

Lipocalins and their Involvement in Innate Immunity and Allergy

Bernhard Redl

We investigate structural and functional features of human lipocalins. The protein superfamily of lipocalins consists of small, mainly secretory proteins defined on the basis of conserved amino acid sequence motifs and their common structure. Functionally, they are important extracellular carriers of lipophilic compounds in vertebrates, invertebrates, plants and bacteria. There is increasing evidence that this group of proteins is involved in a variety of physiological processes including retinoid, fatty acid and pheromone signalling, immunomodulation, inflammation, detoxification, modulation of growth and metabolism, tissue development, apoptosis, and even behavioral processes. Whereas the structural basis of lipocalin-ligand binding is now well understood, there is a major lack of knowledge regarding the mechanisms by which lipocalins exert their biological effects. This is mainly due to the fact that only limited data are available on lipocalin receptors and lipocalin-receptor interactions, although it is well accepted that many, if not all, of these proteins are able to bind to specific cell receptors. Our main research focus is on identification of cellular lipocalin receptors, characterization of molecular mechanisms of receptor-ligand interaction and on biological processes beyond receptor bind-

ing. In addition, we study novel functions of lipocalins in innate immunity and allergy.

Major Achievements:

Isolation of two novel lipocalin receptor candidates by membrane protein cross-linking and phage-display

Future Goals:

- Confirmation of the two receptor candidates as lipocalin receptors by biochemical methods (Isothermal titration calorimetry, Biacore analysis), and by biological assays (cellular up-

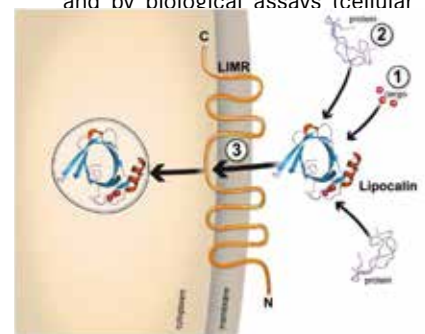

Fig. 4: Types of molecular recognition properties of lipocalins. (1) lipophilic ligands illustrated as cargo. (2) soluble macromolecule ligands such as proteins. (3) a lipocalin-specific membrane receptor is responsible for cellular uptake of the lipocalin-ligand complex.

take studies, knock-down experiments)

Epigenetics and Epitranscriptomics Chromatin Remodeling and RNA Modifications

Alexandra Lusser

Eukaryotic DNA is assembled into a nucleoprotein complex termed chromatin whose basic repeating unit is the nucleosome. The way in which DNA is organized in chromatin allows for highly efficient compaction of the genetic material and provides additional levels of control to the regulation of nuclear processes, such as transcription, replication, repair and recombination. We are interested to learn how the establishment and maintenance of eukaryotic chromatin affects those processes.

We approach this question by studying the molecular mechanisms and biological context of chromatin assembly and remodeling processes. Major research questions in my lab are: (i) The biochemical analysis of chromatin assembly processes using *in vitro* assays and single molecule techniques in collaboration with the lab of C. Dekker (TU Delft), (ii) the study of biological functions

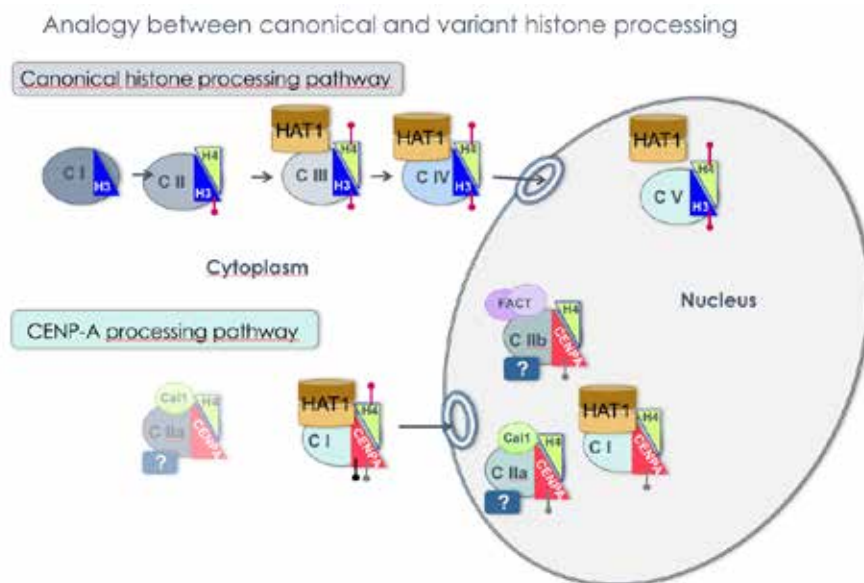

Fig. 5: Working model for the loading mechanism of newly synthesized centromeric histone variant CENP-A into chromatin in *Drosophila*. Similar to what is known for canonical histone loading (upper part), nascent CENP-A is complexed in the cytoplasm with its dimerization partner H4 and the histone acetyltransferase HAT1. HAT1 escorts CENP-A/H4 into the nucleus, where the histones are presumably handed over to other chaperone complexes before incorporation into chromatin at the centromere. C I, II, III, IV – different chaperone complexes (see also Boltengagen et al., *Nucl. Acids Res.* 2016).

of the ATP-dependent chromatin remodeling factor CHD1 in *Drosophila* and in mouse, (iii) the study of centromeric chromatin assembly in *Drosophila* and (iv) the analysis of 5-methylcytosine distribution and function in mammalian mRNA (“epitranscriptomics”).

Major Achievements:

Characterization of CHD1 as a factor required for embryonic stem cell differentiation. Demonstration of CHD-type chromatin remodelling factor regulation during contextual fear extinction learning and in a mouse model for trait anxiety. Involvement of CHD1 in *Drosophila* gut microbiome homeostasis. Elucidation of the role of histone acetyltransferase 1 in CENP-A assembly into chromatin in flies. Demonstration of spontaneous DNA handedness fluctuations in H3/H4 tetrasomes.

Future Goals:

Study the roles of CHD1 in *Drosophila* metabolism. Study the prevalence and physiological significance of RNA cytosine modifications.

Posttranslational Acetylation of Regulatory Non-Histone Proteins

Peter Loidl

Histones are prominent substrates of post-translational modifications, like acetylation, methylation, phosphorylation and others

which all can cause structural and functional rearrangements in chromatin and therefore represent essential elements of the complex epigenetic histone code. During the last years it became more and more clear that a huge number of non-histone proteins are substrates for enzymes that were initially identified as histone-modifying enzymes: this holds true, in particular, for histone acetyltransferases (HATs) and HDACs.

The focus of our research is the analysis of functional consequences of acetylation of non-histone proteins, such as the nucleolar transcription factors UBF and PAF53 and the cell cycle regulatory protein Rb2/p130.

Major Achievements:

Identification of UBF and PAF53 as well as of Rb2/p130 as substrates for post-translational acetylation. Demonstration of cell-cycle dependence of Rb2/p130 acetylation and characterization of the cross talk between Rb2/p130 acetylation and cell cycle-dependent phosphorylation.

Future Goals:

Study of the effects of mutations of acetylatable lysines in Rb2/p130 on cell cycle progression.

Selected Publications

An Iron-Mimicking, Trojan Horse-Entering Fungi-Has the Time Come for Molecular Imaging of Fungal Infections?

Haas, Hubertus, Petrik, Milos, Decristoforo, Clemens, PLOS PATHOGENS: 2015; 11: S. UNSP e1004568

"Invisible" Conformers of an Antifungal Disulfide Protein Revealed by Constrained Cold and Heat Unfolding, CEST-NMR Experiments, and Molecular Dynamics Calculations

Fizil, Adam, Gaspari, Zoltan, Barna, Terezia, Marx, Florentine, Batta, Gyula, CHEMISTRY-A EUROPEAN JOURNAL: 2015; 21: S. 5136-5144

Insight into the antifungal mechanism of *Neosartorya fischeri* antifungal protein

Viragh, Mate, Marton, Annamaria, Vizler, Csaba, Toth, Liliana, Vagvoelgyi, Csaba, Marx, Florentine, Galgoczy, Laszlo, PROTEIN & CELL: 2015; 6: S. 518-528

Embryonic stem cell differentiation requires full length Chd1

Piatti, Paolo, Lim, Chin Yan, Nat, Roxana, Villunger, Andreas, Geley, Stephan, Shue, Yan Ting, Soratroi, Claudia, Moser, Markus, Lusser, Alexandra, SCIENTIFIC REPORTS: 2015; 5: S. 8007

Nucleosome Assembly Dynamics Involve Spontaneous Fluctuations in the Handedness of Tetrasomes

Vlijm, Rifka, Lee, Mina, Lipfert, Jan, Lusser, Alexandra, Dekker, Cees, Dekker, Nynke H., CELL REPORTS: 2015; 10: S. 216-225

A *Penicillium chrysogenum*-based expression system for the production of small, cysteine-rich antifungal proteins for structural and functional analyses

Sonderogger, Christoph, Galgoczy, Garrigues, Sandra, Fizil, Adam, Borics, Attila, Manzanares, Paloma, Hegedues, Nikolettta, Huber, Anna, Marcos, Jose F., Batta, Gyula, Marx, Florentine, MICROBIAL CELL FACTORIES: 2016; 15: S. 192

A novel role for the histone acetyltransferase Hat1 in the CENP-A/CID assembly pathway in *Drosophila melanogaster*

Boltengagen, Mark, Huang, Anming, Boltengagen, Anastasiya, Trixl, Lukas, Lindner, Herbert, Kremser, Leopold, Ofertinger, Martin, Lusser, Alexandra, NUCLEIC ACIDS RESEARCH: 2016; 44: S. 2145-2159

Ergothioneine Biosynthesis and Functionality in the Opportunistic Fungal Pathogen, *Aspergillus fumigatus*

Sheridan, Kevin J., Lechner, Beatrix Elisabeth, O'Keefe, Grainne, Keller, Markus A., Werner, Ernst R., Lindner, Herbert, Jones, Gary W., Haas, Hubertus, Doyle, Sean, SCIENTIFIC REPORTS: 2016; 6: S. 35306

Histidine biosynthesis plays a crucial role in metal homeostasis and virulence of *Aspergillus fumigatus*

Dietl, Anna-Maria, Amich, Jorge, Leal, Sixto, Beckmann, Nicola, Binder, Ulrike, Beilhack, Andreas, Pearlman, Eric, Haas, Hubertus, VIRULENCE: 2016; 7: S. 465-476

A Class 1 Histone Deacetylase with Potential as an Antifungal Target

Bauer, Ingo, Varadarajan, Divyavaradhi, Pidroni, Angelo, Gross, Silke, Vergeiner, Stefan, Faber, Birgit, Hermann, Martin, Tribus, Martin, Brosch, Gerald, Graessle, Stefan, MBIO: 2016; 7: S. e00831-16

Selected Funding

- Study of centromeric chromatin assembly pathways in *Drosophila melanogaster*, MCB0-PhD Program, FWF (2015), Alexandra Lusser
- "The gamma-core motif of antifungal proteins from Ascomycetes", Austrian Science Fund FWF I 3132-B21 (2016), Florentine Marx-Ladurner

Collaborations

Elaine Bignell, Imperial College, London, UK; Axel Brakhage, F. Schiller University Jena, Germany; Robert Cramer, Geisel School of Medicine at Dartmouth, USA; Michael J. Hynes, Univ. of Melbourne, Australia; Jean-Paul Latgé, Institut Pasteur, Paris, France; Antonio DiPietro, Univ. Cordoba, Spain; William Nierman, George Washington Univ., Rockville, USA; Gillian Turgeon, Cornell Univ., Ithaca, USA; Cees Dekker, Nynke Dekker, Technical University Delft, Netherlands; Chin-Yan Lim, A*-STAR, Singapore; Dmitry Fyodorov, Albert Einstein College of Medicine, Bronx, USA; Gyula Batta, University of Debrecen, Hungary; László Galgóczi, University of Szeged, Hungary; Nick D. Read, University of Manchester, UK; José F. Marcos, IATA, Valencia, Spain; Nancy Keller, University of Wisconsin, Madison, USA; Manfred Jung, Albert-Ludwigs-Universität Freiburg, Germany; Antonello Mai, Università degli Studi di Roma "La Sapienza", Italy; Gianluca Sbardella, Università di Salerno, Fisciano, Italy; Arne Skerra, TU Munich, Freising, Germany; Ben J. Glasgow, University of California, Los Angeles, USA.

Experimental Pathophysiology and Immunology



**Head of Division (interim):
Univ.-Prof. Dr. Lukas A. Huber**

Contact:

Biocenter, Innrain 80-82
6020 Innsbruck

Lukas.A.Huber@i-med.ac.at

Phone: +43 512 9003 70171

Fax: +43 512 9003 73960

<http://biocenter.i-med.ac.at/epihome>

Research Branch (ÖSTAT Classification)

301105, 301108, 301109,
301902, 302072

Keywords

Autoimmunity, atherosclerosis, systemic sclerosis, fibrosis, molecular endocrinology, teaching Pathophysiology to Medical and Molecular Medicine students

Research Focus

- The Immunology of Atherosclerosis: Heat shock protein 60, “danger signal” “attracting” preexisting innate and adaptive anti-Hsp60 immunological reactions.
- The Immunology of Fibrosis: Development of peri-silicone mammary implant fibrosis. Impaired function of regulatory T-Cells (Treg).
- Pathogenesis and therapy of systemic sclerosis: Microvascular damage and repair mechanisms. Development of skin fibrosis.

General Facts

The former institute of EXPERIMENTAL PATHOLOGY was initiated in the late 19th century. Moritz Loewit, from the Institute of

“Experimental Pathology” in Prague, moved in 1887 to Innsbruck to become the first professor here. Hermann Pfeiffer was chief from 1919–1921, Gustav Bayer followed him in 1922 and led the institute until 1938 when the NS regime forced him, an intellectual Jew, to end his life. After WW2, Theodor von der Wense rebuilt the institute, and acted as Ordinarius until 1973. He died in 1977 (http://de.wikipedia.org/wiki/Theodor_von_der_Wense). Kurt Loewit, a descendant of the above mentioned Moritz Loewit, took over as interim chief until 1975, when Georg Wick was nominated. Wick – an immunologist with long-term training in USA in the laboratory of Witebsky, the founder of the concept of autoimmunity – extended the institute to a large unit of sometimes 50 collaborators working in different fields, i.e. besides immunology also in endocrinology and molecular biology. A large armamentarium of research as well as diagnostic methods was implemented. Later, the institute was renamed as Institute of PATHOPHYSIOLOGY (reflecting its teaching subject more properly), and finally divided into 3 smaller units (Divisions), i.e.

- Experimental Pathophysiology & Immunology (Georg Wick, later interimistically Lukas A. Huber)
- Molecular Pathophysiology (Reinhard Kofler)
- Developmental Immunology (Andreas Villunger)

All three joined the Biocenter, where they act independently with respect to their research interests, yet are still combined in their teaching duties in what is called BEREICH PATHOPHYSIOLOGIE. Siegfried Schwarz, a member of the Division of Experimental Pathophysiology and Immunology, has coordinated the teaching of Pathophysiology, has written several textbooks, and has contributed substantially to the curricular teaching activities at the MUI till his retirement in 2015. For his continuous commitment to the academic education of Medical students at the Suranaree University of Technology (SUT) in Thailand he received the Honorary Doctorate Degree in Medicine of the SUT in 2016.

Research

The Immunology of Atherosclerosis

Georg Wick

This project of the last two decades resulted in the formulation of a new “Auto-immune Concept for the Development of

Atherosclerosis”, supported by solid data from *in vitro* and animal experiments as well as from cross-sectional and prospective longitudinal studies in human cohorts. In essence, this concept states that classical atherosclerosis risk factors first act as endothelial stressors inducing the expression of a stress protein (heat shock protein 60 – Hsp60), which then acts as a “danger signal” and thus serves as a target for preexisting innate and adaptive anti-Hsp60 immunity. Our present research is focused on a) the elucidation of the migratory pathways of HSP60-reactive T-cells into the arterial intima and b) the continuation and extension of our EU FR7-funded project TOLERAGE that resulted in the development of an Hsp60-based, orally tolerizing vaccine against atherosclerosis. Recently, atherogenic HSP60-peptides were identified in the murine and human systems that may be optimal candidates for such an orally applied vaccine.

The Immunology of Fibrosis

Georg Wick

Fibrosis is an important consequence of various pathological conditions ranging from tissue damage, over inflammation, reactions against foreign body implants to “spontaneous” fibrotic diseases, always being associated with inflammatory immunologic processes. An impaired function of regulatory T cells (Treg) within fibrotic tissues has been recently shown by us. This year, a scientific cooperation aimed at elucidating the development of peri-silicone mammary implant fibrosis was started with groups from the MIT.

Systemic Sclerosis

Roswitha Sgonc

The group is interested primarily in the pathogenesis and therapy of systemic sclerosis (SSc), which is studied in human patients as well as in the spontaneous avian model UCD-200/206, the only animal model that manifests the whole clinical, histopathological and serological spectrum of human SSc. Thus, only the comparative study of UCD-200/206 chickens and human SSc made it possible to identify microvascular endothelial cells as the primary target of the autoimmune attack. After many years studying pathomechanisms and genetic factors underlying the disease, we are now focusing on the development of novel therapeutic approaches. There is an unmet need for an effective pro-angiogenic therapy of ischemic lesions in patients with SSc. Vascular alterations in both, human and avian SSc, predomi-

Pathomechanisms in SSc

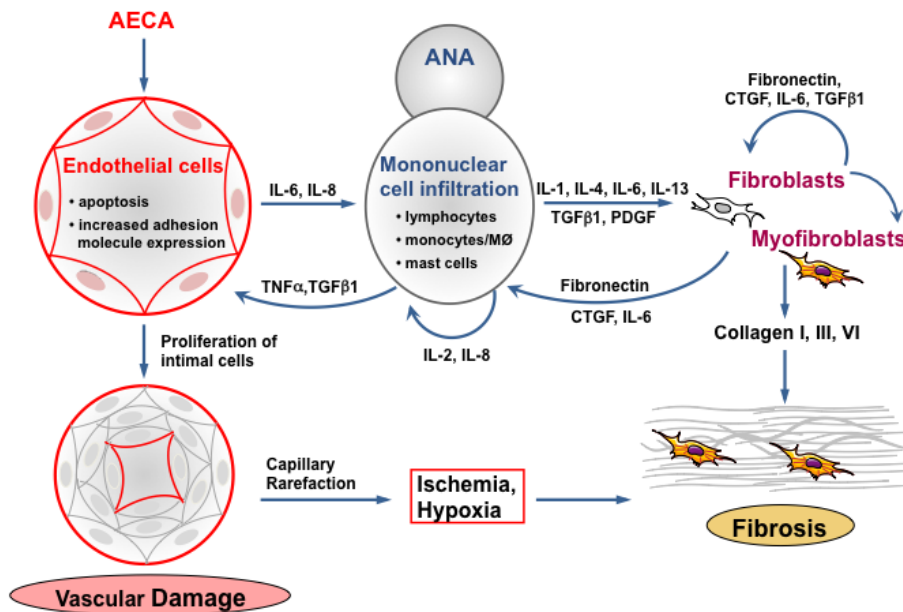

Fig. 1: Model for the development and pathophysiology of systemic sclerosis.

nantly affect the microvasculature. Initially, endothelial cell apoptosis is induced by anti-endothelial cell antibody dependent cellular cytotoxicity (ADCC) via the Fas/ Fas ligand pathway. Intimal proliferation, occlusion of blood vessels, and capillary rarefaction lead to decreased blood flow, a state of chronic ischemia, and to clinical manifestations such as fingertip ulcers and comb lesions. Tissue hypoxia normally induces angiogenesis, but in SSc vascular repair and angiogenesis seem to be strongly disturbed. One of the key molecules in the induction of angiogenesis is vascular endothelial growth factor (VEGF). In SSc chronic and uncontrolled over-expression of VEGF results in chaotic vessels, and intractable fingertip ulcers. Vice versa, VEGF is a potent mediator of angiogenesis if its availability is temporally and spatially controlled. We have addressed this therapeutic dilemma in SSc by a novel approach using a VEGF121 variant that covalently binds to fibrin, and gets released on demand by cellular enzymatic activity, only as long as needed. With this approach we mimic nature, where longer VEGF isoforms are bound to extracellular matrix components until liberated in a tightly controlled manner by local enzymatic activity of cells invading the matrix. Using UCD-206 chickens, we could show that cell-demanded release of locally applied fibrin-bound VEGF121 leads to the formation of morphologically normal blood vessels, and clinical improvement of early and late ischemic lesions. Over all, 79.3%

of the lesions treated with VEGF121-fibrin showed clinical improvement, whereas 71.0% of fibrin treated controls, and 93.1% of untreated lesions deteriorated. This was accompanied by significantly increased growth of stable microvessels, up-regulation of the pro-angiogenic VEGF receptor-2 (VEGFR-2) and its regulator TAL-1, and increase of endogenous endothelial VEGF expression. Long term studies showed lasting effects on improvement and prevention of ischemic lesions supporting the notion that cell-demanded release of fibrin-bound VEGF

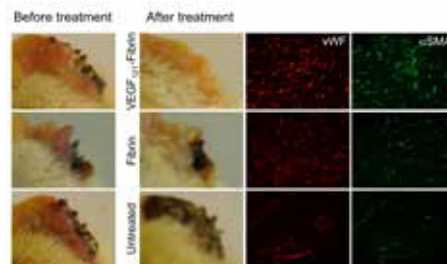

Fig. 2: Effects of topical VEGF121-fibrin therapy on ischemic comb lesions. Seven days after treatment angiogenesis was significantly increased in VEGF121-fibrin treated lesions compared to fibrin treated and untreated controls, resulting in clear clinical improvement. Immunofluorescence double stainings on frozen comb sections of endothelial cells with anti-von Willebrand factor (vWF, red) and mural cells with anti-alpha smooth muscle actin (αSMA, green) antibodies.

is capable of translating a supra-physiological dose into a physiological tiny dose and of sustaining this dose long enough to permit vessels to mature into stable vessels.

Major Achievement:

Effective therapy of ischemic skin lesions in an animal model of SSc.

Prizes:

Publication Prize from the Austrian Society of Rheumatology and Rehabilitation (ÖGR Publikationspreis)

Future Goal:

To study the influence of VEGF121-fibrin therapy on the development of fibrosis in SSc.

Selected Publications

Efficient therapy of ischaemic lesions with VEGF121-fibrin in an animal model of systemic sclerosis
Allipour Birgani, Shadab, Mailänder, Marion, Wasle, Ines, Dietrich, Hermann, Gruber, Johann, Distler, Oliver, Sgonc, Roswitha, ANNALS OF THE RHEUMATIC DISEASES: 2016; 75: S. 1399-1406

Searching for a good model for systemic sclerosis: the molecular profile and vascular changes occurring in UCD-200 chickens strongly resemble the early phase of human systemic sclerosis
Cipriani, Paola, Di Benedetto, Paola, Dietrich, Hermann, Ruscitti, Piero, Liakouli, Vasiliki, Carubbi, Francesco, Pantano, Ilenia, Berardicurti, Onorina, Sgonc, Roswitha, Giacomelli, Roberto, ARCHIVES OF MEDICAL SCIENCE: 2016; 12: S. 828-843

Characterisation of the inflammatory response in Dupuytren's disease
Mayerl, Christina, Del Frari, Barbara, Parson, Walther, Boeck, Guenther, Piza-Katzer, Hildegunde, Wick, Georg, Wolfram, Dolores, JOURNAL OF PLASTIC SURGERY AND HAND SURGERY: 2016; 50: S. 171-179

Mycobacterial heat shock protein 65 (mbHSP65)-induced atherosclerosis: Preventive oral tolerization and definition of atheroprotective and atherogenic mbHSP65 peptides
Grundtman, Cecilia, Jakic, Bojana, Buszko, Maja, Onestingel, Elisabeth, Almanzar, Giovanni, Demetz, Egon, Dietrich, Hermann, Cappellano, Giuseppe, Wick, Georg, ATHEROSCLEROSIS: 2015; 242: S. 303-310

Selected Funding

- Effects of VEGF121 modified fibrin on ischemic lesions in systemic sclerosis: a new therapeutic approach. FWF: P23230-B13, Roswitha Gruber-Sgonc
- Das vaskulär assoziierte lymphoide Gewebe (VALT) bei Atherosklerose. ÖNB Nr. 15953, Georg Wick
- Thymoglobulin Oral, SANOFI Aventis Group, Georg Wick

Collaborations

- Oliver Distler, Center of Exp. Rheumatology, University Hospital Zurich, Switzerland
- Roberto Giacomelli, University of Aquila, School of Medicine, Italy
- Susanne Kerje, Department of Medical Sciences, Uppsala University, Sweden
- Andrew Newby, Bristol Heart Institute, Bristol, UK

Molecular Pathophysiology



**Vice Head of Division (interim):
ao. Univ.-Prof. Dr. Stephan Geley**

Contact:

Biocenter, Innrain 80-82
6020 Innsbruck

Stephan.Geley@i-med.ac.at
Phone: +43 512 9003 70365
Fax: +43 512 9003 73100
[http://biocenter.i-med.ac.at/
molecular-pathophysiology](http://biocenter.i-med.ac.at/molecular-pathophysiology)

**Head of Division (interim):
ao. Univ.-Prof. Dr. Arno Helmborg**

Arno.Helmborg@i-med.ac.at
Phone: +43 512 9003 70366

Research Branch (ÖSTAT Classification)

301109, 301108, 301105, 301101,
301203, 301306, 301904, 304003

Keywords

Mitosis, cell cycle, CDK, APC/C, proliferation, differentiation, development, ciliogenesis, cell death, cancer

Research Focus

- Function of the APC/C activator Fzr1/CDH1 during development, in tissue homeostasis and in ciliogenesis
- Molecular analysis of the kinetochore Spindly-RZZ complex in human cells
- Identification of substrates of CDK16 and functional analysis in human cells
- Molecular characterisation of RBM26, a potential novel ciliopathy gene

- Defining the role of the BCL-2 rheostat in glucocorticoid-induced apoptosis in childhood acute lymphoblastic leukaemia cells

General Facts

The Division of Molecular Pathophysiology has a longstanding interest in the molecular mechanisms that control cellular proliferation and cell death in pathophysiological conditions such as cancer with the ultimate goal of applying this knowledge to improve diagnosis and therapy of human diseases.

We use interdisciplinary approaches and collaborate on the national and international level to better understand the mechanisms of chromosome congression and segregation during mitosis as well as the role of the mitotic ubiquitin ligase APC/C in order to uncover mechanisms that might contribute to aneuploidy, a common hallmark of human malignancies.

Beyond mitosis, we focus on ciliogenesis and non-cell cycle related functions of cyclin-dependent kinases. We try to dissect how the cell cycle control systems govern the formation of primary as well as motile cilia both during the development of vertebrate model organisms as well as in cell lines.

The research of our division is supported by grants from the FWF (Austrian Science Fund) as well as the Tyrolean Cancer Aid Society.

Research

Cell Cycle Control

Stephan Geley

Cyclin-dependent kinases (CDKs) are proline-directed serine threonine kinases that consist of a catalytic and a regulatory subunit, the cyclin. CDKs comprise a family of 20 different cyclin-CDK pairs that are best known for their role in cell cycle regulation and transcription. The cell cycle regulators CDKs are negatively regulated by the mitotic ubiquitin ligase APC/C, which targets the mitotic cyclins for proteasome-dependent degradation. APC/C activity during mitosis required CDK activity and the WD40 repeat protein CDC20, which are required for the onset of anaphase and exit from mitosis. In the ensuing G1-phase CDC20 is substituted for by CDH1/FZR1 to keep the APC/C active until the onset of DNA replication. The switch from high CDK activity during mitosis to low CDK activity during G1 phase is required to allow the resetting of the cell division cycle, for replication licensing, for exit from the cell division cycle,

initiation of differentiation and ciliogenesis. Ciliogenesis requires exit from the cell division cycle, because the basal body, which anchors the cilium at the plasma membrane is derived from the centrosome, which during cell division is otherwise also required for the formation of a bipolar mitotic spindle. Alterations in the cell division cycle can therefore interfere with ciliogenesis. Depending on the molecular structure of the cilium, these antenna-like structures can either be motile or non-motile. Non-Motile, or primary, cilia are found on many cell types and are important signalling domains. Abnormal structure or function of cilia result in a wide variety of conditions that are summarised as ciliopathies and more than 100 genes have been identified so far that contribute to these diseases. During our work on ciliogenesis, we have identified a potential novel player, a poorly characterised RNA-binding protein, whose depletion impaired ciliogenesis. The onset of anaphase and the activation of the APC/C during mitosis is regulated by the spindle assembly checkpoint (SAC). Non- or wrongly attached kinetochores generate an inhibitory signal, the mitotic checkpoint complex MCC, that binds to and inactivates CDC20 to keep the APC/C inactive until correct bipolar attachment to the mitotic spindle is achieved, which results in termination of checkpoint signalling and subsequent APC/C activation, which results in APC/C-dependent securin cleavage and separase activation, which leads to the resolution of cohesin-mediated sister chromatid cohesion, which are then pulled apart to the two poles of the mitotic spindle. Termination of SAC signalling is responsive to microtubule binding and inter- as well as intrakinetochore tension. For checkpoint silencing, kinetochores employ a mechanic means to physically remove checkpoint signalling proteins from the kinetochore in a dynein-dependent manner. Dynein is a large multi-subunit microtubule minus-end directed motor protein that plays multiple roles in mitosis. Dynein is required for the dissolution of the nuclear envelope, chromosome congression to the metaphase plate as well as the onset of anaphase. After nuclear envelope breakdown, dynein and its activatory complex dynactin, are recruited to kinetochores by the Spindly-RZZ complex. This complex binds to kinetochores only during prometaphase by binding to the kinetochore protein ZWINT-1. Spindly is the most peripheral component of this complex and makes direct contacts to dynactin and possibly other dynein subunits. The binding of Spindly to the RZZ

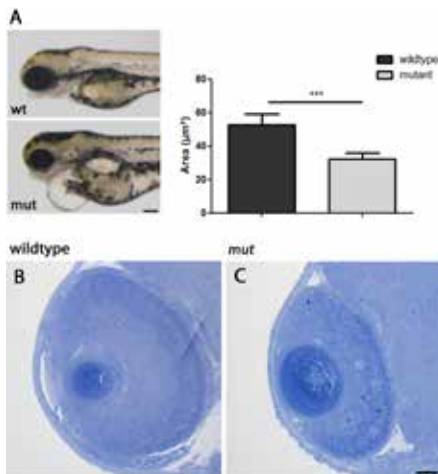

Fig. 1: *RBM26* mutations show kidney cysts and heart edema and smaller eyes (1A). *RBM26* is required for retinal differentiation (1B wildtype, 1C *RBM26* mutant).

complex requires its farnesylation and blocking thereby prevents the recruitment of dynein to kinetochores during mitosis, which results in chromosome congression failures and SAC-mediated arrest in mitosis.

Our work focuses on:

- Understanding the molecular role of Spindly farnesylation
- Understanding the role of the APC/C in G1 phase in ciliogenesis and development
- Understanding the role of poorly-characterised members of the CDK family
- Defining the role of *RBM26* in ciliogenesis

Results:

Farnesylation of Spindly:

By using mass spectrometry we found that only a fraction of Spindly is farnesylated and non-farnesylated Spindly can be detected outside of mitosis. The selective timing of farnesylation of Spindly is due to the sequestration of Spindly from farnesyltransferase due to different subcellular localization, as shown by the analysis of a Spindly mutant harbouring a mutation in the nuclear localisation sequence. In addition, the C-terminus of Spindly is also not processed upon farnesylation as it is in canonical farnesylated proteins, which might explain the absence of detectable membrane binding by Spindly.

APC/C Function in Ciliogenesis and Development:

We have generated conditional *Fzr1* knockout mice and found that *FZr1* is essential for development. When analysing the develop-

ment of *FZr1* zebrafish morphants, several developmental pathways were found to be dampened, which resulted in developmental delay and embryonic death. The pleiotropic phenotype of *Fzr1* depletion might be due to impaired ciliogenesis, due to a failure to downregulate Aurora and CDK kinases, which promotes ciliary resorption and interferes with differentiation. In contrast to these effects during G1-phase, we could not detect effects during exit from mitosis upon *Fzr1* depletion, e.g. in nuclear envelope reformation and timing of cytokinesis.

Functional Analysis of CDK16:

CDK16 is mainly expressed in neurons and the testes and is activated by cyclin Y and cyclin Y-like 1. By using crosslinking mass spectrometry we defined the relative orientation of the CDK subunit and its binding partner and defined a novel role for 14-3-3 proteins in complex assembly and CDK activity. We generated an analogue sensitive variant of *CDK16* and used this enzyme to identify potential protein substrates. Human cancer cell lines lacking *CDK16* or cyclin exhibited reduced WNT signalling, suggesting an important role of this kinase in tumour cell proliferation.

Characterisation of *RBM26*:

RBM26 is a poorly characterised gene harbouring two RNA binding and one PWI domain. The *Drosophila* homolog *swm* is an essential gene involved in cell cycle regulation and/or hedgehog signalling. We defined the expression of human *RBM26* and studied its subcellular localization pattern. By targeting *RBM26* in several human cell lines using the CRISPR-Cas9 system, we ruled out an essential function of *RBM26* in cell lines, but could define an essential function in ciliogenesis. Consistent with a role in ciliogenesis, a zebrafish *RBM26* mutant showed a ciliopathy phenotype (Fig. 1).

Major Achievements:

- Characterisation of Spindly farnesylation
- Identification of *FZr1* function in ciliogenesis
- Identification of *CDK16* targets and function in cancer cells
- Characterisation of the *CDK16*-Cyclin Y-14-3-3 protein complex
- Identification of *RBM26* as a novel ciliopathy gene

Future Goals:

Define the role of post-translational Spindly

modifications during SAC silencing. Define the consequences of *FZr1* depletion in tissue homeostasis. Functional characterisation of *CDK16* substrates. Structural analysis of the *CDK16*-Cyclin Y-14-3-3 protein complex. Characterisation and functional analysis of the *RBM26* interactome.

Selected Publications

Conditional RNAi Using the Lentiviral GLTR System
Pfeiffenberger, Elisabeth, Sigl, Reinhard, Geley, Stephan,
METHODS IN MOLECULAR BIOLOGY: 2016; 1448: S. 121-138

Beclin 1 is dispensable for chromosome congression and proper outer kinetochore assembly
Fava, Luca L., Rainer, Johannes, Haschka, Manuel D., Geley, Stephan, Villunger, Andreas,
EMBO REPORTS: 2015; 16: S. 1233-1236

The NOXA-MCL1-BIM axis defines lifespan on extended mitotic arrest
Haschka, Manuel D., Soratroi, Claudia, Kirschnek, Susanne, Ha-ecker, Georg, Hilbe, Richard, Geley, Stephan, Villunger, Andreas, Fava, Luca L.,
NATURE COMMUNICATIONS: 2015; 6: S. 6891

Selected Funding

MCBO Graduate Program (W1101-P06)

Collaborations

- Barisic M, Danish Cancer Center, Copenhagen, Denmark
- Ben-Aroya, Bar Ilan University, Ramat Gan, Israel
- DiCunto F, University of Turin, Turin, Italy
- Kaldis P, IMCB, A-Star, Singapore
- Maiato H, IBMC, Porto, Portugal
- Sakamoto K, Nestlé Institute of Health Sciences SA, Lausanne, Switzerland
- Vervoorts J, RWTH Aachen University, Aachen, Germany

Developmental Immunology



Head of Division:
Univ.-Prof. Dr. Andreas Villunger

Contact:
Biocenter, Innrain 80-82
6020 Innsbruck

Andreas.Villunger@i-med.ac.at
Phone: +43 512 9003 70380
Fax: +43 512 9003 73960
www.apoptosis.at

Research Branch (ÖSTAT Classification)

301105, 301108, 301902, 301904

Keywords

Apoptosis, tumour biology, non-coding RNAs in haematopoiesis, glucocorticoids, immunology, lymphocyte development

General Facts

The laboratory's work focuses on the developing immune system with an emphasis on cell death signalling and its cross talk to the cell cycle machinery during transformation as well as steroid hormones and miRNA function in the establishment of self-tolerance.

Research

Leukocyte Development, Cell Death & Transformation

Andreas Villunger

BH3-only proteins in cell death and disease
Whether a cell continues to live in response to diverse forms of stress or undergoes apoptosis along the intrinsic cell death signalling pathway is largely determined by the complex interplay between individual members of the BCL2 protein family that

can either promote or prevent apoptosis.

Survival-promoting BCL2 family members, i.e. BCL2, BCLX, BCLW, MCL1 and A1/BFL1 share four Bcl-2 homology domains (BH1-BH4) with each other. All these proteins are critical for cell survival, since loss of any of them causes premature cell death of certain cell types. Consistently, overexpression of BCL2 pro-survival molecules is associated with prolonged cell survival and resistance to cytotoxic drugs in a number of model systems, but more importantly, also in tumour patients. The pro-apoptotic BCL2 family members can be divided into two classes: the BAX-like proteins, i.e. BAX, BAK, BOK that contain four BH-domains (multi-domain pro-apoptotic Bcl-2 proteins) and the BH3-only proteins. The latter include BIM, BID, PUMA, NOXA, BMF, BAD, HRK and BIK that are unrelated in their sequence to each other or other BCL2 family members (except for the BH3-domain).

We study the role of pro-survival BCL2 family proteins and BH3-only proteins using genetically modified model systems in tumourigenesis, lymphocyte development and function.

Caspase-2, cell cycle control and the DNA-damage response

Cells that have been exposed to DNA-damaging agents aim to repair the inflicted damage. However, when this attempt fails, cells usually activate an apoptotic program or senesce to avoid the spread of cells with defective genomes. DNA-damage can also arise in response to mitotic errors or multipolar cell divisions. How mitotic errors trigger cell death or prolonged arrest remains unclear.

The p53-induced protein with a death domain (PIDD)1 has been identified as a gene activated in response to p53 upon DNA damage. Together with the adapter molecule RAIDD, PIDD1 has been implicated in the activation of Caspase-2, an endopeptidase implicated in apoptosis and cell cycle control in a multi-protein complex dubbed the PIDDosome. PIDD1 has recently also been implicated in DNA damage-induced NF- κ B activation and cytokine release, promoting the transcription of inflammatory genes by forming a complex with the kinase RIPK1 and Nemo. Caspase-2 and the PIDDosome have been implicated in multiple cellular responses including the one triggered by deprivation of metabolites, heat shock or DNA damage and senescence. Our work has recently helped to define the role of the PIDDosome as an upstream activator of the tumour suppressor, p53, in response to incomplete cell division (Fig.2).

We are currently investigating the role of these proteins in tumour suppression and organ regeneration and aim to identify Caspase 2-specific substrates to gain further insight into

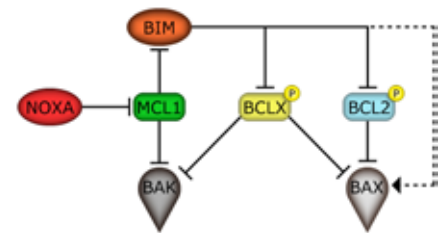

Fig.1: Proposed interrelation of BCL2 family proteins in apoptosis triggered on extended mitotic arrest.

the functions of this multi-protein complex.

Ongoing projects

- MCBO-Doctoral College
- BH3-only proteins in the regulation of mitotic and post-mitotic cell death
- Regulation of BCL2 protein stability during mitosis
- The PIDDosome in sterile inflammation, tumour suppression and regeneration
- Identification of Caspase-2 substrates

Non-coding RNAs in Normal Haematopoiesis & Disease

Sebastian Herzog

In the last decade, our understanding of the human genome and its regulation has dramatically changed. Initially considered to be "junk", it is now clear that the non-protein coding region, which comprises about 98% of the ~3·10⁹ DNA bases, is extensively transcribed and gives rise to numerous non-coding RNAs. The function of these non-coding RNAs, however, is often unclear.

MicroRNAs in Haematopoiesis and transformation

MicroRNAs (miRNAs) are small, non-coding RNAs that mediate post-transcriptional silencing of a predicted 60% of protein-coding genes in mammals. Since their discovery, they have emerged as central mediators of many, if not all biological processes. In our work, we aim to decipher how miRNAs regulate complex transcriptional networks, focusing on lymphocyte development as a well-established model system. In particular, we want to elucidate the role of individual miRNAs under physiological conditions as well as upon aberrant expression, mimicking an oncogenic situation. To this end, we combine gain- and loss-of-function approaches, both *in vitro* as well as *in vivo*, with biochemical and molecular techniques.

Molecular regulation of microRNA function
MiRNA research has traditionally focused on the downstream events, i.e. the identification of target genes that are actively repressed by the microRNA and thus establish a defined phenotype. In contrast, the upstream reg-

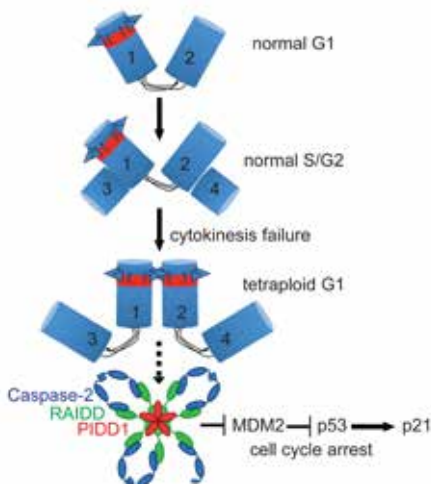

Fig. 2: Proposed model of PIDDosome-mediated cell cycle arrest in response to supernumerary centrosomes.

ulatory networks that feed into miRNA activity have been largely neglected. With few exceptions, it is not known which signalling cascades feed into the transcription of certain miRNAs. Moreover, we only have a limited understanding about the processes that specifically regulate miRNA biogenesis and lack insight into how miRNA decay/turnover is specifically regulated. To shed light onto these different regulatory aspects, we have recently established a genome-wide CRISPR/Cas9 loss-of-function screening platform. With the help of fluorescent sensors for miRNA activity, we are currently using this platform to unravelling the processes that determine and control the function of several clinically relevant miRNAs.

Molecular Immunology

Verena Labi

Protective immunity against pathogens depends on the proper differentiation and maturation of antigen-specific, non-autoreactive B and T lymphocytes from hematopoietic stem cells. Upon recognition of foreign antigens by the B cell receptor, B cells are recruited into germinal centres (GC) in lymphatic tissues where they undergo iterative rounds of proliferation, somatic mutation and selection to differentiate into plasma cells producing high-affinity antibodies and memory B cells. Impairment of B cell development or the GC reaction underlies vaccine failure, improper pathogen clearance, immunodeficiency, autoimmunity and cancer. Transcription factors and signalling molecules guiding these processes are increasingly understood, however much less is known about how the expression of these proteins is regulated. Thus, our aim is to understand the regulatory mechanisms of gene expression that secure proper cell fate

and identity of humoral immune cells and how they impact on antibody production in both health and disease. Specifically, our investigations aim to:

Identifying functionally relevant microRNA-mRNA interactions

Using genetic model systems, we want to understand individual miRNA-mRNA interactions from the mechanistic and physiologic viewpoint. We hope to gain general insights into miRNA-mRNA interaction dynamics. Together with colleagues from the Melamed-group (Technion, Israel) we could show that a c-Myc/miR-17-92/Pten auto-stimulatory axis regulates positive and negative selection of immature B cells. Currently, we focus on exploring the regulation of apoptotic effector molecules by the miR-17-92 miRNAs and the relevance of these interactions for a functional humoral immune response.

Understanding the Role of DNA Demethylation in B Cell Development and Function

We are exploring how the recently identified epigenetic regulators of DNA demethylation, the Tet enzymes, secure proper B cell differentiation and effector functions. In a fruitful collaboration with the Bergman-group (Hebrew University, Israel), we investigated the impact of the Tet enzymes in B cell development. We found that nearly all lineage-specific demethylation during B cell development is mediated by these proteins. Tet enzymes contribute to establishing a functional mature B cell compartment mainly by preventing demethylation of enhancers regulating genes that are critically involved in the control of B cell differentiation.

Regulation of Immunity by Glucocorticoid Hormones

Jan Wieggers

Impact of life span on regulatory T cell maturation and function

Regulatory T cells (Treg) expressing the transcription factor Foxp3 play an essential role in keeping immune homeostasis and preventing autoimmunity. A spontaneous loss of function-mutation in foxp3 in 'scurfy' mice leads to fulminant lymphoproliferation and multi-organ autoimmunity. For a better and more efficient therapy of autoimmune diseases, a more profound knowledge is essential for factors that affect (i) Treg maturation and number in the thymus and (ii) Treg homeostasis under either normal conditions or during the course of an immune response. (iii) It is currently also unclear how life span influences the capacity of Treg to suppress immunity. To study maturation and function of Treg cells, we use foxp3GFP knock-in mice that coexpress GFP under control of the endogenous foxp3 pro-

motor. This allows convenient detection and purification of Treg cells by flow cytometry and the possibility to isolate nearly 100% pure Treg cells.

Glucocorticoids and T cell development

Selection processes in the thymus ensure that mature peripheral T cells fulfil two essential prerequisites: activation by foreign peptides bound to (host) MHC molecules, but tolerance to self-derived peptides presented in the same context. To that end, thymocytes that express T cell receptors (TCRs) with high avidity for self-antigen:MHC and therefore are potentially autoreactive, undergo apoptosis (negative selection). In contrast, thymocytes expressing TCR with moderate avidity for self-antigen:MHC are rescued and differentiate into mature T cells that migrate to the periphery (positive selection). Glucocorticoid hormones (GC) have been suggested to influence these processes, e.g. induce apoptosis in developing T cells, and the thymus itself reportedly produces GC. In addition, GC resistance of thymocytes against GC-induced apoptosis is associated with autoimmune diseases. We focus therefore on the following questions: i) what is the molecular background of thymocyte resistance to GC-induced apoptosis in animal models of autoimmune diseases, and ii) what factors determine sensitivity to GC-induced apoptosis in immature vs. mature thymocytes. To address these questions, we use mice that specifically lack the GC receptor (GR) either in conventional T cells or in Treg cells.

Selected Publications

A c-Myc/miR17-92/Pten Axis Controls PI3K-Mediated Positive and Negative Selection in B Cell Development and Reconstitutes CD19 Deficiency

Benhamou D, Labi V, Novak R, Dai I, Shafir-Alon S, Weiss A, Gajoux R, Arnold R, Shen-Orr SS, Rajewsky K, Melamed D, CELL REPORTS. 2016; 16: S 419-31.

The NOXA-MCL1-BIM axis defines lifespan on extended mitotic arrest
Haschka, Manuel D., Soratroi, Claudia, Kirschnek, Susanne, Haecker, Georg, Hilbe, Richard, Geley, Stephan, Villunger, Andreas, Fava, Luca L., NATURE COMMUNICATIONS: 2015; 6: S. 6891

Conditional knockdown of BCL2A1 reveals rate-limiting roles in BCR-dependent B-cell survival
Sochalska, M., Ottina, E., Tuzlak, S., Herzog, S., Herold, M., Villunger, A., CELL DEATH AND DIFFERENTIATION: 2016; 23: S. 628-639

MAP3K11 is a tumor suppressor targeted by the oncomiR miR-125b in early B cells
Knackmuss, U., Lindner, S. E., Anechky, T., Kotkamp, B., Knust, Z., Villunger, A., Herzog, S., CELL DEATH AND DIFFERENTIATION: 2016; 23: S. 242-252

Selected Funding

- Cell death control on extended mitotic arrest, FWF, Andreas Villunger
- New insights into Bcl2 family: from biophysics to function, FWF, Andreas Villunger
- The role of the PIDDosome in tumor suppression, FWF, Andreas Villunger
- Die Rolle des PIDDosoms in der Tumorentstehung, Villunger A., FWF
- Identifikation von PIDDosom-Aktivatoren für die Krebstherapie, FWF, Andreas Villunger
- Glucocorticoids and regulatory T cells, FWF, Jan Wieggers

Collaborations

- Georg Häcker, Freiburg, DE
- Andreas Strasser, WEHI, Melbourne, AUS
- Pascal Schneider, Lausanne, CH
- Alexander Egle, PMU, Salzburg, AT
- Veronika Sexl, Vienna, AT
- Jörg Hackermüller at Helmholtz Center for Environmental Research (UFZ), Leipzig, DE
- Falus A., Dept. of Genetics, Cell- and Immunobiology (earlier Dept. of Biology) at Semmelweis University, Budapest, HU
- Reul J.M., Laboratories of Integrative Neuroscience and Endocrinology (LINE), University of Bristol, UK
- Boyd R.L., Department of Immunology, Monash University, Clayton, Victoria, Australia

Bioinformatics



Head of Division:
Univ.-Prof. DI Dr. Zlatko Trajanoski

Contact:
Biocenter, Innrain 80-82
6020 Innsbruck

Zlatko.Trajanoski@i-med.ac.at
Phone: +43 512 9003 71401
Fax: +43 512 9003 73100
<http://icbi.at>

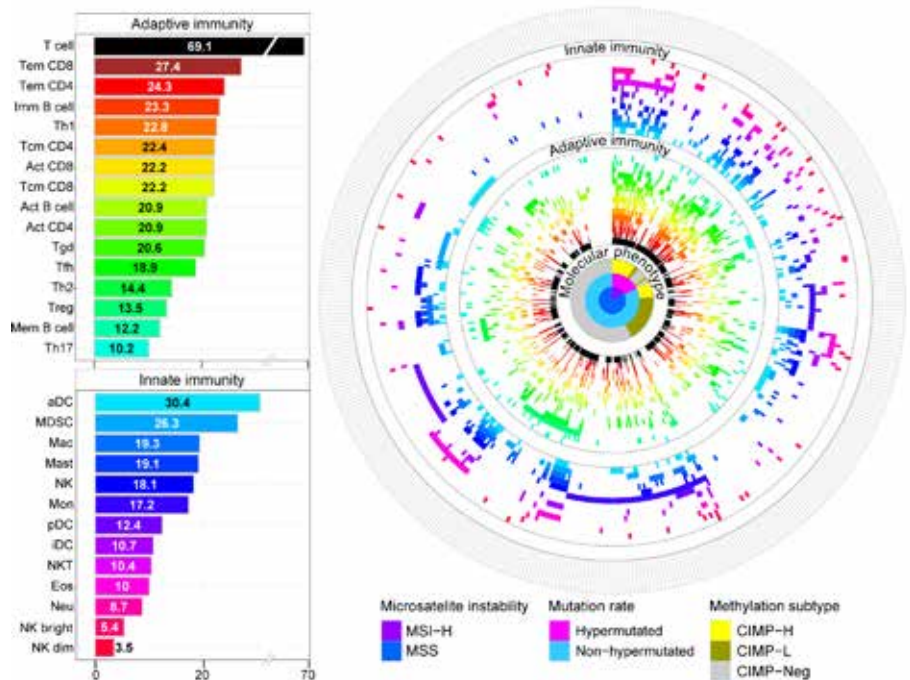

Fig. 1: Genome Biology; Molecular phenotypes and immunophenotypes of colorectal cancers

Research Branch (ÖSTAT Classification)

102004, 106005, 106014,
301902, 301904

Keywords

Bioinformatics, computational biology, genomics

Research Focus

The Division of Bioinformatics has broad expertise in bioinformatics and computational biology. The research includes the development of methods for integrative analyses of heterogeneous data sets and reconstruction of biomolecular networks. A unique feature is the bidirectional flow of information between the experimentalists and the theoreticians. In particular the lab asks biological questions using computational methods and then tests the resultant hypotheses using experimental techniques. The major focus of our research activities is directed towards cancer immunology.

General Facts

The research activities at the Division of Bioinformatics are directed towards two major thrusts:

1. Computational Genomics: In context of

human diseases we explore data of diverse functional genomics using computational methods. We aim to identify and prioritize candidate genes by analyzing high-dimensional data sets, and further characterize their pathways, thus contributing to the understanding of the pathophysiology of diseases.

2. Cancer Immunology : Our aim is to decode the interactions between tumor and immune cells using a combined computational-experimental approach. Specifically, we are interested how the immune system shapes the mutational spectrum of the tumor during progression.

Bioinformatics Services

We provide services regarding bio-informatics for researchers at the Biocenter and at the Medical University of Innsbruck, and also for external collaborators. We maintain a high-performance computational infrastructure and a number of software tools, continuously adapting them to state-of-the-art software technology (see <http://icbi.at>). The software development is directed towards specialized databases, analytical pipelines, and web-services. We additionally advise scientists on designing experiments and support analyses of high-dimensional data sets including NGS (next-generation sequencing) data and imaging data.

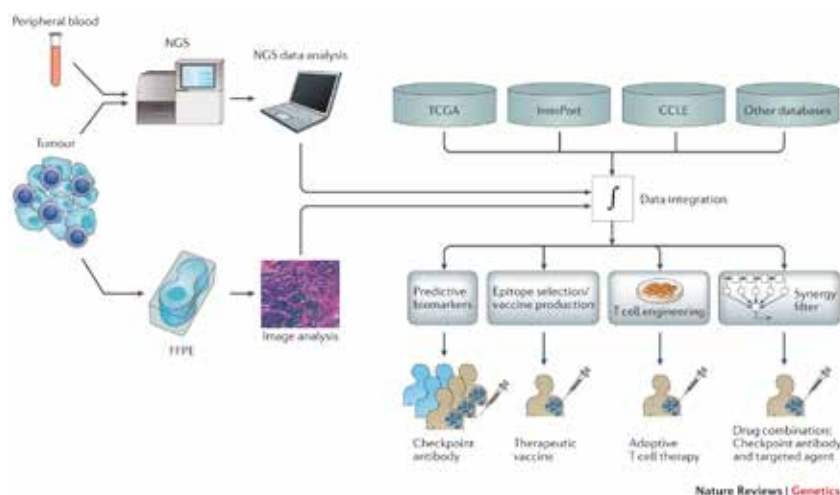

Fig. 3: Nature Review Genetics
 An infrastructure for cancer immunotherapy and precision oncology requires state-of-the-art molecular tools and dedicated IT-Infrastructure

Research

Computational genomics

Recent advances in genome sequencing technologies rapidly change the research and routine work of biologists and human geneticists. Due to the fast decline of costs, NGS is now affordable even for smaller-sized, pure research laboratories. Whole-genome and whole-exome sequencing have proven to be valuable methods for discovering the genetic causes of rare Mendelian disorders and of complex diseases. The current bottleneck is not the sequencing of DNA itself but structured data

management and the sophisticated computational analysis of experimental data. In order to get meaningful biological results, each step of the analysis workflow needs to be carefully considered, and specific tools need to be used for certain experimental setups. Furthermore, the challenge of the 'next-generation biology/genetics' will be to narrow down the list of candidate variants and to interpret remaining variants. The major focus of our research is to narrow down genome search space by integrating and analyzing disparate data sources, including various omics- and clinical-data. We aim to identify causative genes, prioritize candidates for experimental studies, and characterize pathways contributing to the pathophysiology of diseases.

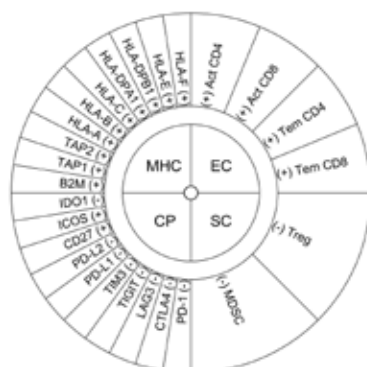

MHC: Antigen Processing
 CP: Checkpoints | Immunomodulators
 EC: Effector Cells
 SC: Suppressor Cells

Fig. 2: Cell Reports
 Immunophenogramm proposed to identify patients responding to immunotherapy with checkpoint blockers

Cancer Immunology

Most advanced solid tumors remain incurable and are resistant to chemotherapeutics and targeted therapies. A series of recent studies reported unexpected intra-tumor heterogeneity which may contribute to this failure. Focusing on the mutational spectrum of various cancers, only little is known so far about the immunogenicity of these mutations and their characteristic immune responses. Identification of non-synonymous mutations, processed and presented in an immunologically relevant way, will highlight the mechanisms driving tumor progression and provide a rich source for novel immunotherapeutic targets. Thus, it is of high importance to decode the cross-talk between tumor and immune system during tumor development. Our long-term goal is to investigate tumor-immune cell interactions in solid tumors. To achieve

this goal, we extensively explore the data available publicly on the immunogenicity of cancer mutanomes, and carry out experimental studies using organoids and mouse models. Additionally, we create mathematical models at various scales and perform simulations that will help us to identify immune signals controlling tumor heterogeneity, clonal evolution and tumor progression. These models and simulations can then be verified experimentally.

Selected Publications

Pan-cancer immunogenomic analyses reveal genotype-immunophenotype relationships and predictors of response to checkpoint blockade
 Charoentong P*, Finotello F*, Angelova M*, Mayer C, Efremova M, Rieder D, Hackl H, Trajanoski Z.
 CELL REPORTS: 2017; 18: S. 248-262

Computational genomics tools for dissecting tumor-immune cell interactions
 Hackl H*, Charoentong P*, Finotello F*, Trajanoski Z.
 NATURE REVIEWS GENETICS 2016; 17: S. 441-458

Characterization of the immunophenotypes and the antigenomes of colorectal cancers reveals distinct tumor escape mechanisms and novel targets for immunotherapy
 Angelova M*, Charoentong P*, Hackl H*, Fischer M, Snajder R, Krogsdam AM, Waldner MJ, Blindea G, Mlecnik B, Galon J, Trajanoski Z
 GENOME BIOLOGY: 2015; 16: S. 64

Selected Funding

- DK MCBO, FWF, Zlatko Trajanoski
- APERIM, EU Horizon2020, Zlatko Trajanoski (coordinator)

Physiology



Head of Division:
Univ.-Prof.ⁱⁿ Dr.ⁱⁿ Michaela Kress

Contact:
Schöpfstr. 41
6020 Innsbruck

Physiologie@i-med.ac.at
Phone: +43 512 9003 70801
Fax: +43 512 9003 73800
www.i-med.ac.at/dpmp/physiologie/

Research Branch (ÖSTAT Classification)

301109, 301110, 301114,
301402, 301406

Keywords

Neurophysiology, renal physiology, muscle physiology, lung physiology, cell volume regulation, non-coding RNA, toxicology, electrophysiology, cell biology, nociception

Research Focus

Scientific research at the Division of Physiology focuses on basic and preclinical translational experimental work in the areas of neurophysiology and the physiology of muscle and epithelial organs. Current research projects include the science of normal biomolecular functions of humans in good health, their organs, and the cells of which they are composed of. Understanding healthy body functions lays the ground to explore the pathogenesis of common diseases like renal dysfunction or chronic pain, amongst a plethora of others. Our research is based on cellular models, organs and systems, and employs an integrated interdisciplinary approach. Particular innovation potential is expected to arise

from ongoing projects developing human iPSCs (induced pluripotent stem cells) into humanised model systems and microRNAs as novel biomarkers and druggable targets for chronic neuropathic pain disorders.

General Facts

The major task of the Division of Physiology is the study and teaching of human physiology. Physiology aims to understand how organisms survive and function. This challenging subject deals with physical and chemical factors responsible for the origin, the development, the progression and even the termination of life. The study of physiology includes (i) the understanding of the activity of a given cell and its interaction with the cellular environment, (ii) the complex interaction of different cell types in tissues and organs and (iii) the interactions of these organ systems which are critical for the maintenance of whole body homeostasis and life. Understanding the healthy function of organisms and their parts, leads to better understanding of processes that occur in diseased states. Eight research groups are involved in cutting edge research on nociception, calcium signalling, cell membranes and renal and alveolar epithelial physiology. We employ a wide range of models and techniques including cell culture, imaging, gene and protein expression, calcium microfluorimetry, high resolution live microscopy and electrophysiology. These eight research groups are partners in local, national and international consortia and are funded by the European Commission, the FWF, the FFG and private foundations.

Research

On the Trail of nervous System Disorders

M. Kress, M. Langeslag

1. Non-coding RNAs

Non-coding RiboNucleic Acids (ncRNAs), their expression and their function are assessed in the nervous system, and in particular in the development of chronic postoperative pain in an FWF funded project. M. Kress coordinates the European research consortium ncrNAPain with local partners A. Hüttenhofer, Z. Trajanoski (both Biocenter), F. Kronenberg (Div. Gen. Epidemiology) and 10 international partners; the aim of this consortium is to decode the role of these biological molecules in the pain system. ncRNAs perform multiple, vitally important roles in our genetic make-

up, in the generation of mental disorders and are further explored in the ceRNAPsych Project funded by the FFG.

2. Bioactive lipids and their role in nervous system function and pathophysiology

Understanding the role of bioactive lipid mediators within the central nervous system has recently gained increasing attention, as it has been connected to major diseases such as multiple sclerosis and Alzheimer's disease. Even though much data about the functions of S1P and LPA receptors has been collected for other organ systems, we still lack a complete understanding of their specific roles, in particular within neurons and the brain. Currently, there is ongoing FWF-funded research on the role of S1P in neuron excitation, regenerative processes and synaptic signalling. Furthermore, the pathogenesis of neuron dysfunction in hereditary lipid storage disorders is investigated.

Function of Calcium Channels in Muscle and Brain

B.E. Flucher, G.J. Obermair

Voltage-gated calcium channels are key regulators of cellular functions in electrically excitable cells. They control the communication between nerve and muscle cells, muscle contraction, and are importantly involved in regulating muscle growth and differentiation during development and in response to exercise. In nerve cells they regulate a variety of vitally important functions including neurotransmitter release, gene regulation, and neuronal plasticity. The importance of voltage-gated calcium channels is reflected by a range of disorders related to aberrant calcium channel functions such as the muscle diseases myotonic dystrophy and malignant hyperthermia as well as

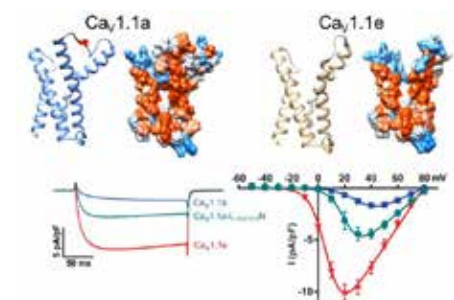

Fig. 1: Structure-function analysis of two functionally distinct splice variants of the skeletal muscle calcium channel revealed the molecular mechanism regulating the voltage-sensitivity of channel activation.

neurological diseases including migraine, epilepsy, autism, ataxia, chronic pain, mood disorders, and Parkinson's and Alzheimer's disease. Our research teams use state-of-the-art molecular genetics, molecular and cell biology, electrophysiology, histology, and high-resolution microscopy approaches to study calcium channel functions in muscle and nerve cells:

1. Calcium channels in the neuro-muscular system

In the past years we elucidated the molecular identity and specific functions of several hitherto unnoticed channel isoforms. Structure-function studies revealed the molecular mechanism underlying the unique biophysical properties of the skeletal muscle calcium channel. Analysis of a genetic mouse model identified the importance of the newly identified calcium channel splice variant for muscle fiber type specification and its involvement in muscle disease. Ongoing experiments examine its role in the formation of the neuromuscular junction during embryonic development. An unexpected observation of a diabetic phenotype in a mouse mutant lacking a specific component of calcium channels revealed the importance of the auxiliary $\alpha_2\delta$ -1 subunit in the blood-glucose regulation by pancreatic β -cells.

2. Calcium channels in the brain

Neuronal functions in the brain are critically regulated by the connections between nerve cells, the synapses. Calcium channels control and fine-tune pre- and postsynaptic functions and consequently a pathologically altered regulation can directly contribute to brain diseases. In our research we could recently identify how a specific subtype of neuronal calcium channels regulates the stability and therefore the function of postsynaptic structures, a finding relevant for synaptic destabilization observed in Parkinson's disease. Beyond their role in regulating the entry of calcium into nerve cells, subunits of calcium channels are also involved in the formation and maintenance of synaptic connections. Thus, in our ongoing research we investigate how the so-called $\alpha_2\delta$ subunits regulate the formation of distinct and specialized synaptic connections

Kidney Function and Mechanisms of Kidney Diseases

G. Gstraunthaler, J. Lechner, P. Jennings

Each kidney consists of approximately 1 million nephrons at birth. De novo nephrogenesis does not occur after birth and there is no strong evidence suggesting that the

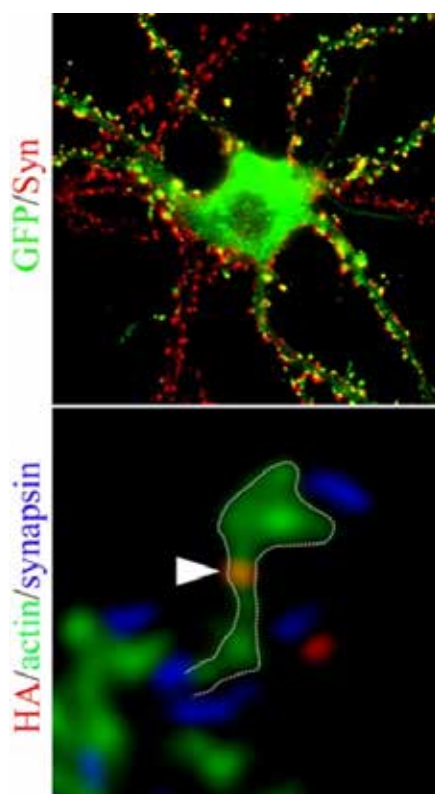

© Gerald Obermair

Fig. 2: Fluorescence microscopy of cultured neurons (upper panel) allowed for the first time super-resolution imaging (lower panel) of calcium channels (red) within dendritic spines (green) opposite synaptic terminals (blue).

adult kidney harbours resident stem cells. Thus, the kidney unlike the liver is not a highly rejuvenative organ, which is most likely an evolutionary compromise allowing the anatomical complexity required for high function and the maintenance of the very narrow margins required for whole body homeostasis. Indeed, the kidney is an extremely accomplished organ and can carry out 100 % of its duties with only a fraction of the nephrons we are born with. However, we continually lose nephrons through-out life and will, all things being equal, eventually breach the renal functional reserve and enter end-stage renal disease. Thus, anything that contributes to chronic renal failure has the potential to seriously curtail life quality and life-span. Aging populations and associated risk factors such as diabetes and heart disease, have pushed chronic kidney disease (CKD) incidence to unprecedented levels (currently at 10 % of the European population).

1. Renal toxicity

Due to the role of the kidney in eliminating

waste products, renal cells, particularly the proximal tubule, will internally process the majority of drugs and chemicals, and thus often have higher concentrations of these compounds than any other cell in the body. Compounds that injure renal epithelial cells can initiate and/or accelerate CKD (chronic kidney disease). The StemBANCC (Stem cells for biological assays of novel drugs and predictive toxicology) is an IMI-funded project with the main aim to produce iPSC from large patient cohorts and differentiate these into target cells. We focus on the differentiation of patient derived iPSC into renal lineages with the aim to use these cells and this technology in drug safety assessment regimes. Robust and reproducible differentiation protocols have been elaborated for proximal tubule like cells and podocyte like cells. In the next phase these cells will be challenged with pharmaceuticals including those known to have renal liabilities. In 2016 the Horizon 2020 EUToxRisk project; "EU-ToxRisk, "An Integrated European 'Flagship' Program Driving Mechanism-based Toxicity Testing and Risk Assessment for the 21st Century" was launched, where the Jennings laboratory is a partner involved in investigating molecular mechanisms of chemical induced nephrotoxicity. The project aims to create human based in vitro testing platforms for kidney, liver, lung and brain; with the aim to improve regulatory decision making using non-animal methods.

2. Sex differences in the kidney

The research focus of the Lechner group is the study of sex differences in the kidney. Sex differences between men and women affect most, if not all, organ systems in the body, but there is a significant gap in knowledge of female physiology aside from organ functions involved in reproduction. Regarding the kidneys, while international registries show that fewer women than men develop kidney failure, the underlying causes are unknown. To investigate, the research team has examined whether hormone changes due to the female menstrual cycle might affect kidney cells. For this purpose, urinary samples from healthy women of reproductive age were collected daily and analyzed for menstrual cycle-associated changes of different proteins. Specifically, 2 enzymes – fructose-1,6-bisphosphatase and glutathione-S-transferase- α – were measured that are found in proximal tubular cells, the most populous cell type in the kidney. When proximal tubular cells are damaged, these enzymes are released into the urine, making them

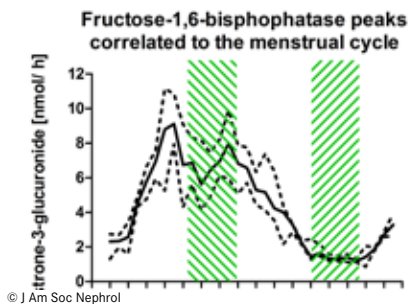

Fig. 3: Fructose-1,6-bisphosphatase peaks correlate to the menstrual cycle: Estrogen urinary metabolite (Estrone-3-glucuronide) concentrations over the menstrual cycle of healthy ovulating women are shown as median (solid line), 25th and 75th percentile (dashed lines). Ovulation day is displayed as day 0. The hatched area represents the two time windows, in which urinary excretion of a proximal tubular marker protein, namely urinary Fructose-1,6-bisphosphatase, peaks with respect to the remaining cycle. Both phases are characterized by a preceding drop of the estrogen level. (from Seppi et al J Am Soc Nephrol 2016: https://www.asn-online.org/about/press/releases/ASN_PR_20160422_JASNLechner886Final.pdf)

important clinical markers for kidney injury. The investigators detected transient increases of fructose-1,6-bisphosphatase and glutathione-S-transferase-alpha correlating with specific phases of the female reproductive hormone cycle, namely ovulation and menses. This result suggests that cyclical changes of female hormones might affect kidney cell health, potentially providing women with an increased resistance against kidney damage. It is conceivable that recurring changes of sex hormone le-

vels, as brought about by the natural menstrual cycle, might be involved in periodic tissue re-modeling not only in reproductive organs, but to a certain extent in the kidneys as well. Understanding the mechanisms that might be responsible for women's lower susceptibility to kidney failure may help design better kidney-related therapies for women and men.

Respiratory Cell Physiology

T. Haller

Quantitative as well as qualitative perturbations in the pulmonary surfactant system of different etiologies, including a disruption of type II cell homeostasis, are increasingly considered as underlying causes of a spectrum of idiopathic respiratory and interstitial lung diseases, some of which are associated with a significant morbidity and mortality. The research of the group of T. Haller focuses on the regulation and mechanisms of surfactant secretion by type II pneumocytes, the significance and the biophysical properties of surfactant at the respiratory air-liquid interface, and on alveolar epithelial cell physiology in general. In 2016 the group could resolve an old enigma concerning the absolutely essential role of the surfactant protein B (SP-B) whose experimental inactivation leads, within hours, to lethal respiratory failure. We showed that SP-B is acting as a catalytic 'zipper' to open the compact surfactant complexes immediately upon their first contact with the respiratory air-liquid interface. Inhibition of this process blocks the formation of an active surface coat which normally counteracts the strong recoil tendency of alveoli, in particular after end-expiration. In other projects, dedicated to pharmacological topics, we found an

explanation for the stimulatory effect of Mucosolvan on surfactant release: This drug acts by depletion of acidic Ca²⁺ stores in AT II cells via a simple, and probably widespread pharmacodynamic principle - a drastic breakdown of vesicular H⁺ gradients with an ensuing discharge of Ca²⁺ ions. Since its introduction by an early work of T. Haller, this topic gained a strong upsurge in the last few years, in particular in the field of neurodegenerative disorders. Currently, the team is also active in establishing improved cell culture systems and in exploiting label-free optical methods to resolve surfactant biogenesis and its nanostructure in live cells.

Insulin Secretion and Cell Volume Regulation

J. Fürst

Diabetes mellitus occurs throughout the world but is more common (especially type 2) in more developed countries. Its prevalence is increasing rapidly and an estimated 750 million people will have diabetes by 2030. Although genetic background and environmental (i.e. dietary) factors have been associated with diabetes pathogenesis, the underlying physiological mechanisms need to be explored in more detail. Our main interest is studying the physiology of pancreatic beta cells *in vitro*, with a focus on the role of cell volume regulatory mechanisms as well as reactive oxygen species and antioxidants in insulin secretion and beta cell survival.

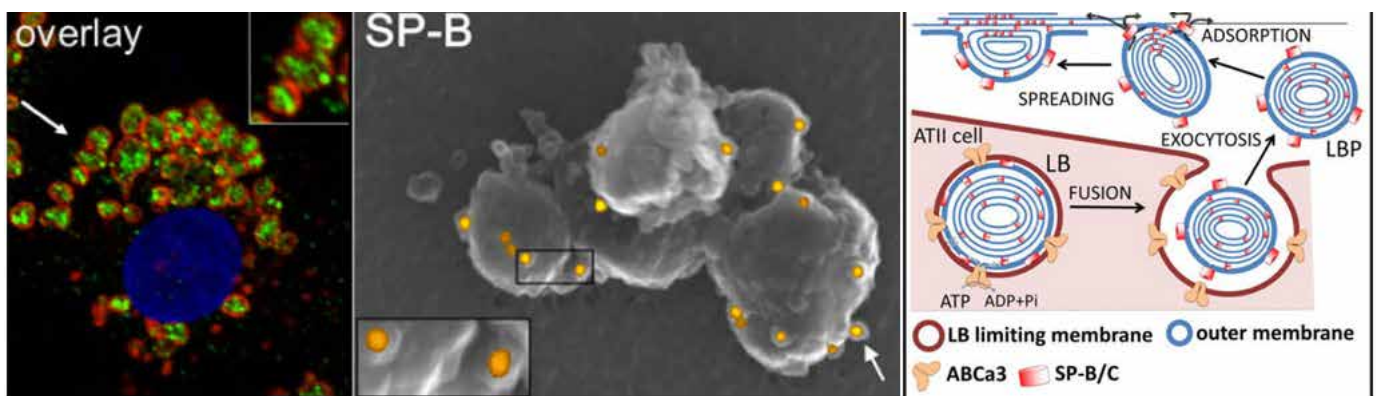

© Biochim. Biophys. Acta 1863 (2016): 2124-2134

Fig. 4: ABCa3 (red) and SP-B (green) distribution in an alveolar type II cell (left). Immunogold SEM demonstrating SP-B (yellow) on the surface of exocytosed surfactant (center). Model for SP-B dependent adsorption of surfactant complexes at an air-liquid interface (right)

Selected Publications

Ablation of Sphingosine 1-Phosphate Receptor Subtype 3 Impairs Hippocampal Neuron Excitability In vitro and Spatial Working Memory In vivo

Weth-Malsch, Daniela, Langeslag, Michiel, Beroukas, Dimitra, Zangrandi, Luca, Kastenberger, Iris, Quarta, Serena, Malsch, Philipp, Kalpachidou, Theodora, Schwarzer, Christoph, Proia, Richard L., Haberberger, Rainer V., Kress, Michaela,
FRONTIERS IN CELLULAR NEUROSCIENCE: 2016; 10: S. 258

Development and characterization of a pseudo multiple re- action monitoring method for the quantification of human uromodulin in urine

Hammond, Thomas G., Moes, Suzette, Youhanna, Sonia, Jennings, Paul, Devuyt, Olivier, Odermatt, Alex, Jenö, Paul.,
BIOANALYSIS: 2016; 8: S. 1279-1296

Inter-laboratory study of human in vitro toxicogenomics-based tests as alternative methods for evaluating chemical carcinogenicity: a bioinformatics perspective

Herwig, R., Gmuender, H., Corvi, R., Bloch, K. M., Brandenburg, A., Castell, J., Ceelen, L., Chesne, C., Doktorova, T. Y., Jennen, D., Jennings, P., Limonciel, A., Lock, E. A., McMorrow, T., Phrakonkham, P., Radford, R., Slattery, C., Stierum, R., Vilardell, M., Wittenberger, T., Yildirimman, R., Ryan, M., Rogiers, V., Kleinjans, J.,
ARCHIVES OF TOXICOLOGY: 2016; 90: S. 2215-2229

A small key unlocks a heavy door: The essential function of the small hydrophobic proteins SP-B and SP-C to trigger adsorption of pulmonary surfactant lamellar bodies

Hobi, Nina, Giolai, Michael, Olmeda, Barbara, Miklavc, Pika, Felder, Edward, Walthner, Paul, Dietl, Paul, Frick, Manfred, Perez-Gil, Jesus, Haller, Thomas,
BIOCHIMICA ET BIOPHYSICA ACTA-MOLECULAR CELL RESEARCH: 2016; 1863: S. 2124-2134

Restricting calcium currents is required for correct fiber type specification in skeletal muscle

Sultana, Nasreen, Dienes, Beatrix, Benedetti, Ariane, Tuluc, Petronel, Szentesi, Peter, Sztrétye, Monika, Rainer, Johannes, Hess, Michael W., Schwarzer, Christoph, Obermair, Gerald J., Csernoch, Laszlo, Flucher, Bernhard E.,
DEVELOPMENT: 2016; 143: S. 1547-1559

Splice variants of the Ca(V)1.3 L-type calcium channel regulate dendritic spine morphology

Stanika, Ruslan, Campiglio, Marta, Pinggera, Alexandra, Lee, Amy, Striessnig, Joerg, Flucher, Bernhard E., Obermair, Gerald J.,
SCIENTIFIC REPORTS: 2016; 6: S. 34528

Two distinct voltage-sensing domains control voltage sensitivity and kinetics of current activation in Ca(V)1.1 calcium channels

Tuluc, Petronel, Benedetti, Bruno, de Bagnaux, Pierre Coste, Grabner, Manfred, Flucher, Bernhard E.,
JOURNAL OF GENERAL PHYSIOLOGY: 2016; 147: S. 437-449

Quercetin Stimulates Insulin Secretion and Reduces the Viability of Rat INS-1 Beta-Cells

Kittl, Michael, Beyreis, Marlina, Tumurkhuu, Munkhtuya, Fuerst, Johannes, Helm, Katharina, Pitschmann, Anna, Gaisberger, Martin, Glasl, Sabine, Ritter, Markus, Jakab, Martin,
CELLULAR PHYSIOLOGY AND BIOCHEMISTRY: 2016; 39: S. 278-293

Sex Differences in Renal Proximal Tubular Cell Homeostasis

Seppi, Thomas, Prajczek, Sinikka, Doerler, Maria-Magdalena, Eiter, Oliver, Hekl, Daniel, Nevinny-Stickel, Meinhard, Skvortsova, Iraidia, Gstraunthaler, Gerhard, Lukas, Peter, Lechner, Judith,
JOURNAL OF THE AMERICAN SOCIETY OF NEPHROLOGY: 2016; 27: S. 3051-3062

Selected Funding

- ceRNAPsych, FFG, M. Kress
- NIPPS, FWF, M. Kress
- SPIN, Doctoral College FWF, M. Kress
- EU-ToxRisk, "An Integrated European 'Flagship' Program Driving Mechanism-based Toxicity Testing and Risk Assessment for the 21st Century", Horizon 2020, Jennings
- StemBANCC "Stem cells for Biological Assays of Novel drugs and predictive toxicology" EU 7th Framework and EFPIA. Jennings and Gstraunthaler
- SFB F4415-B23, Importance of Cav1.3 intra- and extracellular modulators for synapse stability in normal and diseased striatal MSNs, FWF, (G. Obermair and B. Flucher)
- FWF, P27031: The role of calcium channels in acetylcholine receptor pre-patterning during neuromuscular junction development (Flucher)
- FWF, W1101: Doctoral College in "Molecular Cell Biology and Oncology" 4th funding period; Speaker: B. Flucher (Flucher)
- FWF Herta Firnberg Project: Molecular mechanisms of the STAC3-Cav1.1 interaction in skeletal muscle EC coupling. T855, (M. Campiglio, co-applicant B.E. Flucher)

Collaborations

- Josef Penninger, IMBA, Vienna, Austria
- Hermona Soreq, Hebrew University Jerusalem, Israel
- Rohini Kuner, University Heidelberg, Germany
- Claudia Sommer, University Würzburg, Germany
- Paul Heppenstall, EMBL Monterotondo, Italy
- Marzia Malcangio, Kings College London, UK
- Marc Landry, University Bordeaux, France
- Amy Lee, University of Iowa, Iowa City, USA
- Jörg Striessnig, University of Innsbruck, Austria
- Jutta Engel, Saarland University, Homburg, Germany
- Jing Hu, University of Tübingen, Germany
- Martin Heine, Leibniz Institute for Neurobiology, Magdeburg, Germany
- Petronel Tuluc, University of Innsbruck, Austria
- Valentina Di Biase, Medical University of Graz, Graz, Austria
- Veit Flockerzi, Saarland University, Homburg, Germany
- Laszlo Csernoch, University of Debrecen, Hungary
- Vladimir Yarow-Yarovoy, University of California Davis, Davis CA, USA
- Frederic Bois, University of Compiègne / INERIS, France
- Wolfgang Dekant, University of Würzburg, Germany
- Bob van de Water, Leiden University, The Netherlands
- Martin Leonard, Public Health England, UK
- Norman P. Curthoys, Colorado State University, Ft. Collins, CO, USA
- Zam Cader, University of Oxford, UK
- Paul Dietl, University Ulm, Germany
- Jesus Perez-Gil, Complutense University, Madrid, Spain
- Markus Ritter, Paracelsus Medical University, Salzburg, Austria

Biomedical Physics



Head of Division:
o. Univ.-Prof. in Dr. in
Monika Ritsch-Marte

Contact:
Müllerstraße 44
6020 Innsbruck

Monika.Ritsch-Marte@i-med.ac.at
Phone: +43 512 9003 70870
Fax: +43 512 9003 73870
www.i-med.ac.at/dmp/bmp

Research Branch (ÖSTAT Classification)

206003, 103037, 302044,
103021, 103040

Keywords

Biophotonics, optical trapping, acoustic trapping, nonlinear microscopy, Raman microscopy (coherent and spontaneous), digital holographic microscopy, phase contrast, spatial light modulators, UV measurements, solar UV radiation

Research Focus

Programmable Microscopy: wavefront shaping with Spatial Light Modulators inside an optical microscope, to emulate and customize “classic” microscopy techniques or to create new techniques.

Highlights: spiral phase contrast, multi-plane imaging, single-shot quantitative differential interference contrast, lensless imaging through a scattering medium, programmable confocal microscopy.

Acoustically-assisted Optical Trapping: contact-free handling of microscopic particles (micro-organisms, micro-beads, living cells, cell organelles, or DNA-strands) with

laser light.

Highlights: trapping of the largest swimming micro-organisms ever trapped “all-optically”; combined acoustic and optical trapping of even larger specimens.

Solar UV Radiation: optimisation of spectroradiometric instruments and development of analysis techniques for solar radiation spectra and aerosol optical depth.

Highlights: the Austrian UV measurement network (UV-Index).

General Facts

The Division of Biomedical Physics pursues application-oriented basic research projects devoted to the development of novel optical methods and technologies in medicine or cell biology. Currently there exist two Research Groups: the Biomedical Optics Group and the UV-Radiation Group. The research has largely been funded externally, e.g. by FWF, ERC (Advanced Investigator Grant catchIT, Ritsch-Marte, 2010-2015), and EU networks.

The Biomedical Optics Group has a high visibility in the international Biophotonics community, in particular for contributions to Holographic Optical Tweezers and to Synthetic Holographic Microscopy using wavefront shaping with so-called Spatial Light Modulators, miniaturized liquid crystal displays with individually addressable micrometer-sized pixels.

The UV-Radiation group is interested in various aspects of solar UV radiation. They optimise spectroradiometric instruments and develop analysis techniques to measure solar radiation spectra and aerosol optical depth, as well as operating the Austrian UV monitoring network.

Recent Special Recognitions and Awards:

The Division of Biomedical Physics has hosted several international conferences in the last few years, including the Trends in

Optical Manipulation conference series in Obergurgl.

M Ritsch-Marte was recently elected full member of the Austrian Academy of Sciences. Alexander Jesacher is also affiliated to the University of Erlangen via his Young Researcher Award (SAOT Award).

Research

Biomedical Optics

RESCH-Microscopy

We have developed a scanning microscopy method for the acquisition of volumetric sample information from planar scans. The method, which we termed RESCH (= “refocusing after scanning using helical phase engineering”), can be considered a variant of Image Scanning Microscopy where the imaging point-spread-function (PSF) has been changed such that 3D information can be efficiently collected, e.g. by bringing the detection PSF of a scanning microscope into a helical shape. Suitable data post-processing allows for the reconstruction of volumetric data from a single planar scan. Fig.1(a) shows a RESCH-microscopy example of a fluorescently stained microtubule-network in fixed COS-7 cells. The entire data was collected in a single 2D-scan (NA 1.25, wavelength: excitation/emission = 640/670 nm). By setting specific “virtual pinholes” that select the raw-data points to be integrated, one can retrieve individual sections of the 3D sample from different axial positions around the focal plane.

High Resolution Confocal Raman Microscopy

We have constructed one of the highest-resolving confocal Raman systems, boosting the spatial resolution of confocal Raman microscopy by a factor of about 1.25. This improvement was achieved by implementing a specifically designed fiber-based light collection system with multiple line-readout on

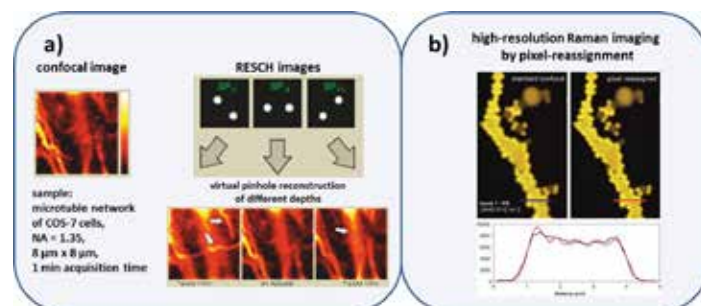
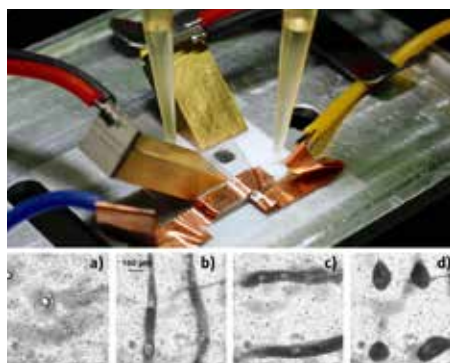

Fig. 1: Super-resolution techniques developed in Innsbruck: a) RESCH microscopy allows one to reconstruct 3D information from specially recorded 2D scan by post-processing based on “virtual pinholes”. b) Improved resolution in Raman microscopy by exploiting the pixel-reassignment technique (also known as “Image Scanning Microscopy”).



Top: Prototype device for 3D acoustic trapping for hybrid optical and acoustic trapping supporting high resolution imaging. Bottom: Demonstration of acoustic trapping of yeast cells with dynamic control of the trapping strength in all directions: With confinement only along the vertical direction, the cells are levitated within a plane (a) without surface contact. Additional acoustic fields acting along the horizontal axis force the cells into stripes (b, c), or 3D clusters (d). The spectrometer CCD together with a data post-processing method known as “pixel-reassignment”. Fig. 1 (b) demonstrates this, showing a cluster of polystyrene micro-beads, imaged in the spectral band from 3045 to 3112 wavenumbers with a commercial confocal Raman microscope (left), and our resolution-improved Raman microscope (right). The images show the cumulative energy detected in the respective band.

Color-dependent Point Spread Function Engineering

Based on our earlier work on multi-colour diffractive optics, we could demonstrate wavelength-sensitive pupil phase engineering in microscopy. We showed that the Stokes shift of common fluorophores is sufficient to provide largely independent phase modulation for the excitation laser and the emitted fluorescence using a single diffractive optical element. This enables a new, more versatile sort of pupil phase engineering.

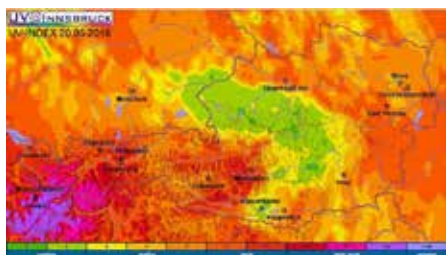

Fig. 3: The Div. for Biomedical Physics operates the Austrian UV measurement network generating the on-line UV-Index for Austria, which is updated every few minutes.

Hybrid Optical and Acoustic Trapping

While optical trapping in a single, focused laser beam offers very precise manipulation of small particles such as single cells, it lacks the ability to handle many (thousands) particles or large specimens ($> 10 \mu\text{m}$). In contrast, acoustic trapping in standing ultrasound waves is well suited for parallel handling of many/large particles, but without the ability of single particle control. Thus we have developed a hybrid device that combines the strengths of acoustic and optical trapping, as well as facilitating high-resolution optical imaging. A major challenge was to gain a proper understanding of how the acoustic resonances within the device are affected by the close contact between the device and the microscope immersion lens, requiring careful characterization of the acoustic properties by means of force measurements by optically trapped test particles. Even 3D acoustic trapping with good optical access is becoming feasible, to shape and probe large (up to several $100 \mu\text{m}$) cell clusters in a contact-less manner (cf. Fig. 2).

UV Radiation

The main aim of the research group is the measurement of solar radiation in the spectral range from the UV to the near IR, to investigate various aspects relevant for humans and the biosphere. Specific research topics include UV radiation, aerosols and trace gases in the atmospheric column (air quality) and the study of complex radiative transfer scenarios in the land-atmosphere system.

The research group maintains two measurement sites, one in Innsbruck (at the roof of the University of Innsbruck) and one at a mountain site above the city (Hafelekar). Routine measurements of aerosol optical depth (with a sun photometer), cloudiness (sky camera) and erythral UV radiation (Biometer) are performed to compile climatological time series for a representative location in an alpine valley. Other more specific research questions are targeted in dedicated field campaigns. Detailed model simulations of the measurements are performed with a full 3D state-of-the-art radiative transfer model.

In the laboratory, we develop and characterize diode array spectroradiometer systems, to adopt them for solar measurements, with emphasis on stray light, absolute radiometric calibration and stability. Specific algorithms are developed and optimized to exploit the information content of solar spectra with respect to atmospheric composition. Based on the long-established competence

for high quality UV measurements, the research group is responsible for the quality control and publication of the Austrian UV monitoring network within a long term research grant of the Austrian Governmental Department for Environment. At the moment, the results of 16 stations in Austria and nearby Bavaria and Switzerland are published in near real time (www.uv-index.at), together with a regional map, showing the distribution of the level of UV exposure modulated by the actual cloud cover, derived from actual pictures of the Meteosat satellite (cf. Fig. 3). The data are presented in units of the ‘uv-index’, which is an internationally agreed quantity for harmful UV exposure, taking into account the sensitivity of the human skin for UV radiation. An example of these maps is shown in Fig. 3, where also the measurement sites are marked. It gives the maximum UV-index on 20.05.2016, clearly influenced by cloudiness and topography.

The capability for absolute UV measurements is also applied to characterize artificial UV sources as e.g. used in sun beds in solariums. In cooperation with international agencies (e.g. Commission Internationale de l’Eclairage CIE) these data are interpreted in terms of harmful and potentially healthy effects. Also measurements in connection with workplace security and protection were carried out.

Selected Publications

Acoustic force spectroscopy

Sitters, Gerrit, Kamsma, Douwe, Thalhammer, Gregor, Ritsch-Marte, Monika, Peterman, Erwin J.G., Wuite, Gijis J.L., NATURE METHODS: 2015; 12: S. 47-50

Three-dimensional information from two-dimensional scans: a scanning microscope with postacquisition refocusing capability

Jesacher, Alexander, Ritsch-Marte, Monika, Piestun, Rafael, OPTICA: 2015; 2: S. 210-213

Cortical contractility triggers a stochastic switch to fast amoeboid migration in 3D environments

Ruprecht, V., Wieser S., A. Callan-Jones, M. Smutny, H. Morita, K. Sako, V. Barone, M. Ritsch-Marte, M. Sixt, R. Voituriez, C.Ph. Heisenberg, CELL: 2015; 160; S. 673-685

Quality assessment of solar UV irradiance measured with array spectroradiometers

Egli L., J. Gröbner, G. Hülsen, L. Bachmann, M. Blumthaler, J. Dubard, M. Khazova, R. Kift, K. Hoogendijk, A. Serrano, A. Smedley, J. Vilaplana ATMOSPHERICAL MEASUREMENT TECHNIQUES: 2016; 9: S. 1553-1567

Acoustic force mapping in a hybrid acoustic-optical micromanipulation device supporting high resolution optical imaging

Thalhammer, Gregor, McDougall, Craig, MacDonald, Michael P., Ritsch-Marte, Monika LAB ON A CHIP: 2016; 16: S. 523-1532

Selected Funding

Extension of the Christian Doppler Laboratory for Microscopic and Spectroscopic Material Characterisation (MS-MACH), Christian Doppler Forschungsgesellschaft, (Coordinator Assoc. Prof. D. Stifter, Johannes Kepler Universität Linz), Ritsch-Marte Monika, 2010–2017

Collaborations

- Padgett, Miles, University of Glasgow, UK
- Piestun, Rafael, University of Colorado, Boulder, USA
- Wuite, Gijis, Vrije Universiteit Amsterdam, Amsterdam, The Netherlands
- Nevas, Physikalisches-Technische Bundesanstalt, Berlin, Germany
- Gröbner, World Radiation Center, Davos, Switzerland

Cell Genetics



Head of Division:
Univ.-Prof. Dr. Gottfried Baier

Contact:
Peter Mayr Straße 1a
6020 Innsbruck

Gottfried.Baier@i-med.ac.at
Phone: +43 512 9003 70514
Fax: +43 512 9003 73518
www.baierlab.com

by a complex activation process involving differentiation of the resting cell into a proliferating lymphoblast that actively secretes immune-regulatory cytokines or displays targeted cytotoxicity, ultimately leading to recruitment of innate immune cell types and the initiation of an effective immune response.

In order to understand the physiology and pathophysiology of T lymphocytes, it is necessary to decode the biochemical processes that integrate the signals received from antigens, cytokines, and integrins as well as inhibitory receptors. Our work aims to explore and identify gene products of distinct members of the AGC family of protein serine/threonine kinases and their effector substrates that act as key players in mediating proper T cell-mediated immunity and in fine-tuning the immune response outcome. The underlying goal of the work is to understand the selective functions of these proteins in signal transduction pathways in lymphocytes and to use this information to develop strategies for manipulating the immune response, either in order to promote immunosuppression in the context of autoimmune diseases, graft rejection and inflammatory responses or for augmentation as a cancer immunotherapy-

based approach.

Research

Cell Genetics Team:

Gottfried Baier, Natascha Kleiter, Thomas Gruber, Nikolaus Thuille, Kerstin Bellaire-Siegmund, Victoria Klepsch, Karin Albrecht-Schgör, Sebastian Peer, William Olson, Nina Posch, Michaela Kind et al.

Because of its biological complexity, cancer is still poorly understood. Chronic inflammation has been shown, both experimentally and epidemiologically, to predispose to and also to be an inseparable aspect of clinically prevalent cancer entities. Therefore, understanding the breakdown of both tumour and immune cell functions in cancer progression is of utmost importance to better fight this frequently incurable disease. My team was the first to reveal the lymphocyte-intrinsic PKC/NR2F6/CBLB axis as an essential signalling node at the crossroads between inflammation and cancer. It is our mission to identify molecular signatures that influence the risk of developing inflammation-associated tumours, employing established research tools and state-of-the-art genetic, biochemical, proteomic and transcriptomic

Research Branch (ÖSTAT Classification:

106002, 301109, 301905, 301301

Keywords

T lymphocyte signalling, T cell effector differentiation and function, intracellular immune checkpoints, autoimmunity, cancer immunity, innovative immunological therapy concepts.

Research Focus

Our team has expertise in signal transduction, mouse genetics, the differentiation of effector/memory T cells and the ability of these cells to alter adaptive immune responses. In particular, we have gained experience in investigating molecular signalling processes through the use of hypothesis-driven mechanistic studies and by utilising unbiased mass spectrometry based screens and next generation sequencing to characterise novel protein-protein and protein-DNA interactomes and transcriptomes.

General Facts

The function of mature T cells is to recognize and respond to foreign antigens

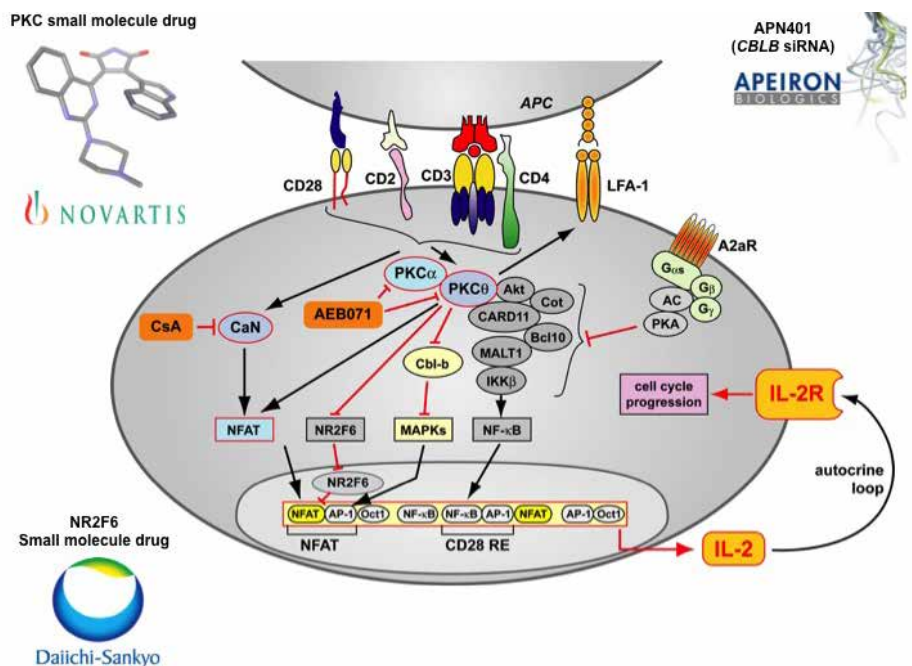

Fig. 1: The major research topic of the group relates to the biochemical, molecular and functional analysis of the signal transducing protein kinase network within the haematopoietic system.

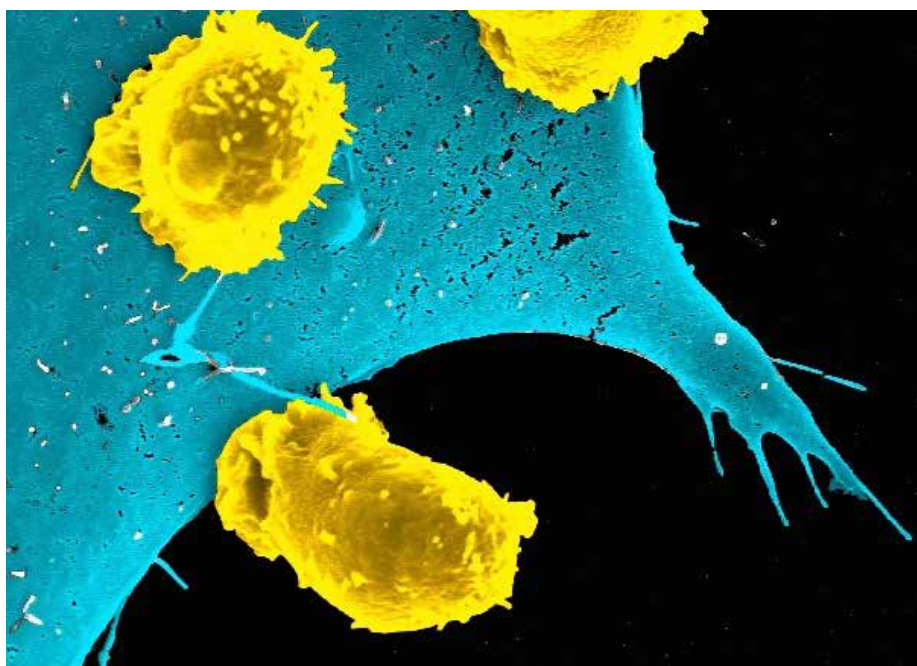

Fig. 2: Our research aims to elucidate the underlying inter- and intracellular mechanisms that shape the T cell compartment (in yellow) to recognize and reject a tumour cell (in blue).

as well as large scale *in vitro* and *in vivo* CRISPR/Cas9 perturbation screening-based functional genomic technologies. Defining this as yet poorly elucidated effector pathway with its profoundly relevant role would enable development of preventive and immune-therapeutic strategies against cancer and potentially also against other immune pathologies. Our three-pronged approach to achieve this goal is to: (i) delineate biological and clinical properties of the immunological PKC/NR2F6/CBLB network, (ii) develop a cutting-edge CRISPR-mediated gene knockout generation strategy rendering adoptively transferred T cells capable of rejecting tumours and their metastases at distal organs and (iii) exploit human combinatorial T cell therapy concepts for prevention of immune-related adverse events as well as of tumour recurrence by reducing opportunities for the tumour to develop resistance in the clinic. Insight into the functions of the NR2F6/CBLB axis and involved mechanisms is a prerequisite for understanding how the microenvironment at the tumour site either supports tumour growth and spread or prevents tumour initiation and progression, the latter by host-protective cancer immunity.

Selected Publications

Proof of Principle for a T Lymphocyte Intrinsic Function of Coronin 1A.
Siegmond K, Klepsch V, Hermann-Kleiter N, Baier G, Siegmond, Kerstin, Klepsch, Victoria, Hermann-Kleiter, Natascha, Baier, Gottfried, JOURNAL OF BIOLOGICAL CHEMISTRY: 2016; 291: S. 22086-22092

Inhibition of CBLB protects from lethal *Candida albicans* sepsis
W Wirmsberger, Gerald, Zwolanek, Florian, Asaoka, Tomoko, Kozieradzki, Ivona, Tortola, Luigi, Wimmer, Reiner A., Kavirayani, Anoop, Fresser, Friedrich, Baier, Gottfried, Langdon, Wallace Y., Ikeda, Fumiyo, Kuchler, Karl, Penninger, Josef M., NATURE MEDICINE: 2016; 22: S. 915-+

cJUN N-terminal kinase (JNK) phosphorylation of serine 36 is critical for p66Shc activation.
Khalid, Sana, Drasche, Astrid, Thurner, Marco, Hermann, Martin, Ashraf, Muhammad Intiaz, Fresser, Friedrich, Baier, Gottfried, Kremser, Leopold, Lindner, Herbert, Troppmair, Jakob, SCIENTIFIC REPORTS: 2016; 6: S. 20930

The Nuclear Orphan Receptor NR2F6 Is a Central Checkpoint for Cancer Immune Surveillance.
Hermann-Kleiter, Natascha, Klepsch, Victoria, Wallner, Stephanie, Siegmond, Kerstin, Klepsch, Sebastian, Tuzlak, Selma, Villunger, Andreas, Kaminski, Sandra, Pfeifhofer-Obermair, Christa, Gruber, Thomas, Wolf, Dominik, Baier, Gottfried, CELL REPORTS: 2015; 12: S. 2072-

Novel protein kinase C theta: coronin 1A complex in T lymphocytes.
Siegmond, Kerstin, Thuille, Nikolaus, Posch, Nina, Fresser, Friedrich, Baier, Gottfried, CELL COMMUNICATION AND SIGNALING: 2015; 13: S. 22

Collaborations

- Jürgen Wagner and Gerhard Zencke; Novartis Pharma, Basel, Switzerland;
- Michael Leitges, Biotechnology Centre of Oslo, University of Oslo, Norway;
- Noah Isakov, Ben Gurion University of the Negev, Israel;
- Wallace Langdon, University of Western Australia, Perth, AUS;
- Arthur Kaser, Department of Gastroenterology, Cambridge, UK

Selected Fundings

- T cell-intrinsic role of PKCalpha in canonical TGFbetaR signalling (G. Baier), FWF P25044 450k€, 2013-2016
- CBLB inhibitory signalling pathways in cancer (G. Baier) FFG BRIDGE, 842388, CBL-AIM, 400k€, 2014-2016
- Christian Doppler Laboratory for immune therapy-mediated cancer rejection via NR2F6 blockade (G. Baier), CDL I-CARE, 630k€, 2016-2018
- PhD program in „Molecular Cell Biology and Oncology“ (2 Pls: G. Baier and N. Kleiter), FWF DK-MCBO, 300k€, 2014-2019
- PKCtheta/Coronin 1A axis in CD4+ T cell subpopulations (K. Bellaire-Siegmond) FWF-Lise Meitner Program M1636, 160k€, 2014-2017
- Analysis of the TGFbeta/CBLB pathway in autoimmunity and tumour immunity (T. Gruber), FWF P26892, 320k€, 2014-2017
- NR2F6 governs immune defense against microbial pathogens (N. Kleiter), FWF P28694, 320k€, 2016-2019

Genetic Epidemiology



Head of Division:
Univ.-Prof. Dr. Florian Kronenberg

Contact:
Schöpfstraße 41
6020 Innsbruck

Florian.Kronenberg@i-med.ac.at
Phone: +43 512 9003 70560
Fax: +43 512 9003 73561
<http://www3.i-med.ac.at/genepi>

Research Branch (ÖSTAT Classification):

102004, 102010, 301301,
301302, 303007

Keywords

Genetic epidemiology, lipoprotein metabolism, complex phenotypes, genome-wide association studies, mitochondrial DNA, computational genetics, cloud computing, structural biology, risk factors, cardiovascular disease, biomarkers

Research Focus

We aim to identify determinants of health and disease related to genetic variability, environmental components and biochemical parameters and to study their physiological or pathophysiological functions. Our phenotypes of interest are complex in nature due to their interplay and are related to atherosclerosis, diabetes mellitus, metabolic syndrome, cancer, and associated intermediate phenotypes such as lipoprotein metabolism and inflammation.

General Facts

Our Institute with about 18-20 members

serves as a bridge between basic and clinical research. We have three different pillars that develop their strength by an interleaved collaboration. 1) A protein chemistry and cell culture laboratory performs a variety of structure-functional and epidemiologic studies regarding various phenotypes related to lipoprotein metabolism and other metabolic phenotypes. 2) A molecular-genetic lab performs sequencing and genotyping for various projects, with a strong focus on mitochondrial DNA as well as on targeted evaluation of certain candidate genes. 3) The computational & statistical genetics lab focusses on statistics, epidemiology, computer science and bioinformatics and represents an important cross-link between the various research groups. During the last few years a pronounced entanglement of these three "units" to a strongly collaborating alliance became more and more evident. There is almost no major project in which not at least two main groups are involved. Besides these three pillars our institute harbours the "Sequencing & Genotyping Core Facility" offering Sanger-sequencing, large scale genotyping services, and management of large epidemiological studies. New technologies such as Nanopore sequencing or digital droplet PCR recently became a major focus of this facility. The output and success of our institute is based on a constant dialogue between the various disciplines in a problem-oriented and critical elucidation of research questions.

Research

Lipoprotein(a)

Claudia Lamina, Stefan Coassin, Florian Kronenberg

High concentrations of lipoprotein(a) [Lp(a)] are a risk factor for cardiovascular disease. These high concentrations are mostly genetically influenced by the so-called low molecular weight apo(a) isoforms that double the risk for cardiovascular disease. These isoforms are determined by a large and highly complex genetic region ("KIV-2 repeat") in the *LPA* gene which is still poorly characterized. Despite this strong genetic regulation, Lp(a) concentrations of individuals with the same isoform combination can vary 200-fold. This suggests that Lp(a) levels are modified by additional genetic variants which have to be identified. We recently completed two major research projects to identify such variants:

1. A Large Genome-Wide Association Study Meta-analysis of Lp(a) Concentrations involving more than 13,781 partici-

pants investigated almost 10 million single nucleotide polymorphisms (SNPs): we identified 48 SNPs in the *LPA* gene region, which were all associated with Lp(a) concentrations independently from each other as well as independently from the apo(a) isoforms. A SNP-score with Lp(a)-increasing alleles showed an increase of median Lp(a) values from 2.1 mg/dL to 91.1 mg/dL from the minimum to the maximum number of alleles (Figure 1). The SNP with the highest effect on Lp(a) concentrations is also associated with an 80% higher risk for coronary artery disease for each copy of the minor allele. In addition, we found the APOE2-determining allele of rs7412 in the *APOE* gene to be significantly associated with Lp(a) concentrations. Each APOE2 allele decreased Lp(a) by 3.34 mg/dL corresponding to $\approx 15\%$ of the population's mean values.

2. A Large Mutation Screening Project Searching for Mutations in the KIV-2: we

hypothesized that the KIV-2 might contain unknown variants, which affect Lp(a) concentrations. To elucidate this question we developed in a first step novel sequencing technologies and bioinformatic approaches to sequence 123 samples with different Lp(a) phenotypes. In a second step we confirmed the most promising finding in an additional 2,892 participants from the general population. This revealed a novel variant present in 22% of the population, which strongly reduces Lp(a) concentrations by 21 mg/dL and markedly reduces the increased cardiovascular risk of individuals with the low molecular weight apo(a) phenotypes (Figure 2). Knowledge about the carrier sta-

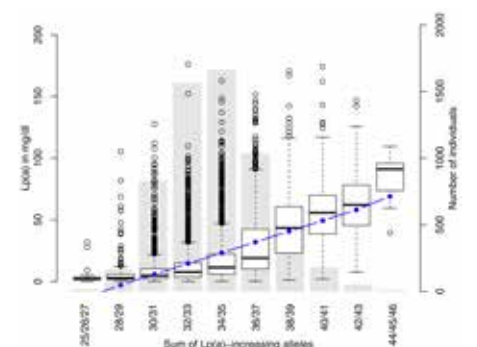

Fig. 1: Boxplot of Lp(a) concentration for groups of a SNP-score (sum of Lp(a)-increasing alleles), derived from the 48 independent SNPs in the broad LPA gene region. An underlying barplot shows the distribution of the score in KORA F3 and KORA F4. The blue line indicates the predicted values of Lp(a) for mid-interval values of the SNP-score, based on a linear regression from the SNP-score on Lp(a).

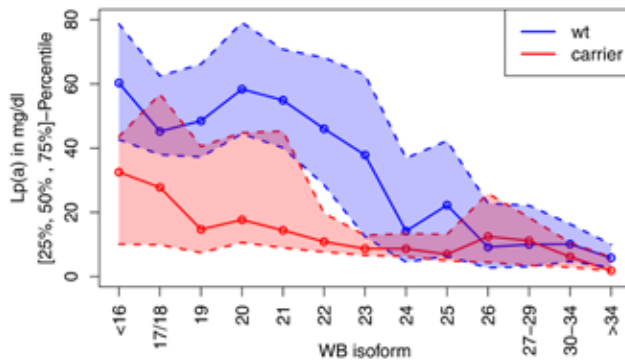

Fig. 2: Effects of 4925G>A variant on median Lp(a) concentrations: Carriers of this newly discovered genetic variant located within the KIV-2 copy number variation show markedly reduced Lp(a) concentrations especially in isoforms which are regarded as low molecular weight apo(a) isoforms (Western Blot (WB) isoforms ≤ 23 K-IV repeats).

thus therefore improves patient classification and contributes to the understanding of the extremely large variability of Lp(a) levels observed in low molecular weight apo(a) isoform carriers. In collaboration with the Division of Cell Biology (Mariana Eca Guimaraes Araujo PhD, Univ. Prof. Dr. Lukas A. Huber) and the Division of Genomics and RNomics (Univ. Prof. Dr. Alexander Hüttenhofer), we finally observed that this variant decreases splicing efficiency *in-vitro* and is associated with a reduced amount of protein originating from the mutant allele.

Apolipoprotein A-IV

Claudia Lamina, Barbara Kollerits, Stefan Coassin, Florian Kronenberg

Apolipoprotein A-IV (apoA-IV) is a glycoprotein, which has anti-atherogenic properties. We showed already earlier that apoA-IV is increased in the early stages of chronic kidney disease and that it predicts progression of chronic kidney disease. We could recently generalize this association of apoA-IV with kidney function to the general population: in a combined analysis of two population-based studies (about 6000 participants) we could show that high apoA-IV concentrations are associated with reduced kidney function independently of classical risk factors for chronic kidney disease. Therefore, apoA-IV can be used as an early marker to indicate renal impairment even in the general population. One very important question follows these results: is apoA-IV only a marker for kidney disease or does it causally influence kidney function or vice versa? This question cannot be answered by observational epidemiological studies alone. Since apoA-IV is partly genetically regulated, a statistical method known as Mendelian Randomization can serve as a valuable tool to answer the question of causality. To be able to use this method, one has to know genetic variants which influence apo-IV on the one hand and kidney function on the other hand. Until recently the knowledge on genetic regulation of

apoA-IV concentrations was very limited. Therefore, we initiated a genome-wide meta-analysis comprising the data of seven studies including about 16000 participants. Two independent SNPs located in or next to the *APOA4* gene and one SNP in the *KLKB1* gene were identified. It was possible to initiate the next step of analysis with these three identified SNPs and other already published results from genome-wide studies: a Mendelian randomization study to evaluate the causal direction of the relation between apoA-IV and kidney function. Surprisingly, we could show that the estimated glomerular filtration rate (eGFR) as a measure of kidney function influences apoA-IV and not the other way round.

Afamin

Barbara Kollerits, Claudia Lamina, Florian Kronenberg, Bernhard Rupp, Hans Dieplinger

Our research focused primarily on the epidemiology and the biochemical and structure-functional characterization of afamin, a previously described vitamin E binding protein expressed primarily in the liver and circulating in the bloodstream. We previously showed a strong association of afamin plasma concentrations with all parameters of the metabolic syndrome. Our most recent analysis revealed a strong association of elevated afamin concentrations and the prevalence and incidence of type 2 diabetes mellitus in a meta-analysis totalling >20,000 human subjects from 8 population-based cohorts. Furthermore, we found afamin to be strongly predictive for the development of hepatic steatosis (commonly associated with the metabolic syndrome) in 1500 participants of the population-based Young Finn Study during a 10-year follow-up. In order to unravel mechanistic insights into the (patho)physiological functions of afamin, we essentially chose two methodological approaches: first, a human hepatic cell line (HepG2), established very recently, and permanently expressing afamin via the TALEN genome editing technology. With

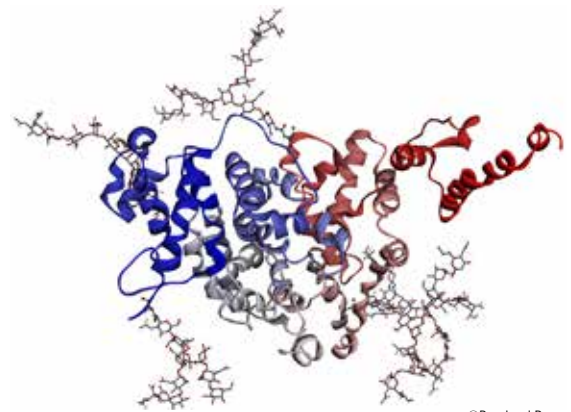

©Bernhard Rupp

Fig. 3: Structural model of afamin

this cell-culture model we will investigate the regulation of afamin expression in a series of *in-vitro* experiments as well as the influence of afamin on the secreted lipoprotein/lipid pattern. Second, we have initiated an ambitious project centered on a structure-guided approach to understand the function and properties of afamin. Despite its disease-association and similarity to albumin indicating a significant potential of acting as a general lipophilic drug transporter, other than homology models (Figure 3) nothing is known about the molecular structure and its relation to known and unknown functions of afamin. Analysis of the molecular structure of afamin and of its complexes with small molecule ligands is an effective means to reveal the origin of its functional diversity, allowing critical evaluation of its transport properties and whether and how it might have any potential as a possible therapeutic target. Any results from these studies will therefore be completely new and of significant ground-breaking interest as a milestone result in the structural biology and blood plasma transport/lipoprotein research community. Several expression systems for afamin have been developed so far, allowing the optimal strategy for crystallizing afamin. The structure of one of the available monoclonal antibodies against afamin (N14) has already been determined and described. Possible complexes of this and other antibodies will also be attempted and their structure determined.

Mitochondrial DNA

Hansi Weissensteiner, Liane Fendt, Florian Kronenberg, Lukas Forer, Sebastian Schönherr

Our projects on mitochondrial DNA (mtDNA) currently focus on three topics:

- 1. Bioinformatic tools for mtDNA sequence analysis and genotyping** to unravel the path of our female ancestors to the detection of disease: mitochondria possess their own DNA which is inherited by women only. This allows classification of mtDNA profiles into haplogroups that are important in evolutionary, forensic and medical genetics. We developed an automatic classification in 2011, HaploGrep, which is used by many groups worldwide; recently we

presented a markedly extended version, HaploGrep 2. A further powerful tool is the mtDNA-Server which is designed to identify low-level variants in mtDNA Next-Generation-Sequencing projects. Both tools were published in the Web server Issue 2016 of "Nucleic Acids Research", are freely available and led to many cooperations worldwide.

2. Cancer Research Sequencing Projects: Mitochondria, playing a vital role for energy production, are thought to be involved in the initiation of cancer formation. By taking advantage of Next-Generation Sequencing (NGS) and the previously described mtDNA-Server, we analyze low-level mutations (heteroplasmies) in the mitochondrial DNA in cancer/benign tissue pairs. We could show the reliability of NGS to detect somatic mtDNA mutations in oral squamous cell carcinoma. We currently try to shed light on mutational and tissue specific differences in tumor and benign prostate samples, with a range of different methods such as NGS, High-Resolution Respirometry (HRR) and RNA-Sequencing. The cancer research projects are in collaboration with the Departments of Cranio-, Maxillofacial and Oral Surgery, Urology, Pathology, the Division of Bioinformatics, the Institute of Analytical Chemistry and Radiochemistry of the University Innsbruck and Oroboros Instruments.

3. mtDNA Copy Number Determination: the mitochondrial content in a cell reflects the energy demand of a particular cell and changes might cause diseases with an oxidative phenotype. For these reasons the measurement of copy number variation recently became a hot topic, the standardization of the measurement, however, is a nightmare. We therefore have set up a duplex quantitative PCR based assay for determination of mitochondrial DNA copy number relative to nuclear DNA. A plasmid containing both targets is used for normalization and drastically reduces the intra-assay variability.

Telomere Length

Barbara Kollerits, Claudia Lamina, Florian Kronenberg

Telomeres are non-coding, repetitive DNA sequences at the end of linear chromosomes, reaching a length of 5-15kb. Their principle task is to sustain chromosomal integrity by capping and protecting DNA. With aging, linear DNA shortens progressively with each cell division due to the inability of DNA polymerase to completely replicate to the very end. When telomere length has become critically short cellular senescence

or apoptosis is induced. We have contributed several papers over the last 8 years to this research area showing associations of relative telomere length with cardiovascular disease or cancer. In the most recent clinical study we found a pronounced association between shorter relative telomere length and prevalent cardiovascular disease in almost 5000 patients from the German Chronic Kidney Disease (GCKD) Study. In a methodological study we were able to demonstrate that the DNA extraction method has a pronounced influence on the measurement of relative telomere length. If this observation is not adequately considered in epidemiological studies, the probability of spurious or lost associations is quite high.

Large international Meta-analysis Projects

Claudia Lamina, Barbara Kollerits, Florian Kronenberg

Epidemiological and genetic-epidemiological studies often are possible only if many groups worldwide contribute their data for a meta-analysis. Each single study alone would not have the statistical power to find an association between a certain biomarker or a genetic variant with an outcome of interest (e.g. cardiovascular disease or diabetes). We therefore organize or contribute data from our cohorts to many consortia which in the end often include data from millions of investigated individuals in their analysis. In the past we have headed meta-analyses on adiponectin and apolipoprotein A-IV concentrations, ankle-brachial-index or peripheral arterial disease. We currently perform analyses on concentrations of Lp(a), apolipoprotein A-IV and afamin, and are leading an analysis of chronic kidney disease and its influence on the development of peripheral arterial disease in more than 800,000 prospectively followed individuals.

Providing Large Genetic Services at no Costs

Lukas Forer, Sebastian Schönherr, Hansi Weissensteiner, Florian Kronenberg

The computational lab of the Genetic Epidemiology focuses on methods and tools development in the area of genetic research. Several cloud-based genetic services have been developed and provided to researchers at no costs: mtDNA-Server provides a free service for the analysis of human mitochondrial DNA data, currently focusing on reliable identification of heteroplasmy ($\geq 1\%$) and contamination. The Michigan Imputation Server provides a free genotype imputation service where GWAS genotypes

can be uploaded (VCF or 23andMe format) receiving phased and imputed genomes in return (Figure 4). This service has been developed in cooperation with the University of Michigan and the Eurac Research Centre (led by Christian Fuchsberger and Goncalo Abecasis). It is one of the currently largest available genetic services that imputed > 10 million genomes and is used by >2,000 active users. The underlying approach and methods have been published in three Nature Genetic papers with several collaborators: The main paper describes the Michigan Imputation Server architecture itself and improvements to the imputation machinery. The second contribution introduces the new HRC reference panel (Haplotype Reference Consortium) of 64,976 haplotypes at 39,235,157 SNPs constructed using whole genome sequence data from 20 studies of predominantly European ancestry. The third paper illustrates the new phasing algorithm "Eagle2" that attains high accuracy across a broad range of cohort sizes by efficiently leveraging information from large external reference panels (such as the Haplotype Reference Consortium, HRC). All three contributions have been integrated into the Michigan Imputation Server

Registry for Familial Hypercholesterolemia (FH)

Hans Dieplinger

Since 2015, Hans Dieplinger has been in charge of a project aiming at establishing an Austrian-wide registry for individuals affected with familial hypercholesterolemia (FH). This initiative is a central activity of the Austrian Atherosclerosis Society (AAS) and is organised in close collaboration with related scientific disciplines and societies

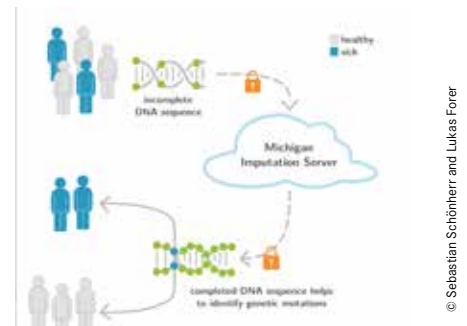

Fig.4: Principle of the Michigan Imputation Server: first incomplete DNA sequences derived from genotyping of e.g. 500,000 SNPs are uploaded to the server. Second by comparing with the complete reference DNA of more than 32,000 samples the unknown DNA stretches are statistically imputed to receive a DNA sequence as complete as possible.

(cardiology, internal medicine, pediatrics, human genetics, epidemiology, laboratory medicine) and the Austrian patient organization FHchol Austria.

FH is a frequent metabolic disorder correlating with a high risk of premature cardiovascular disease. With an estimated prevalence of 1:250, we can expect about 30,000 affected individuals in Austria. However, more than 90% of them are not yet diagnosed and adequately treated. Mutations in three genes [LDL receptor (LDLR), apolipoprotein B (APOB) and proprotein convertase subtilisin/kexin type 9 (PCSK9)] are the major causes of FH. The inheritance is autosomal-dominant. Elevated LDL-C concentrations in individuals with heterozygous FH may cause premature cardiovascular events. Thanks to effective cholesterol-lowering therapies including apheresis as well as novel medication that prove to have even better results, FH can be managed effectively.

The registry is currently under development and the first patients and their families will be registered soon

Nanopore Sequencing („MinION“)

Stefan Coassin, Hansi Weissensteiner, Sebastian Schönherr

Nanopore sequencing is the most recent sequencing technology (Figure 5). The most

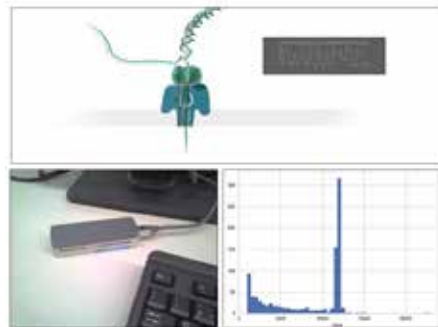

© Oxford Nanopore Technologies

Fig 5: Principle of Nanopore sequencing (top panel), the USB-stick sized MinION System (bottom panel, left) and the read length achieved during an experiment of Nanopore sequencing a more than 10,000 bp large plasmid (bottom panel, right). Nanopore sequencing is based on the measurement of the electric potential changes while a DNA strand is translocated through a protein pore and allows read lengths far beyond 10 kb (limited in principle only by the length of the DNA preparation). The possibility to trivialize sequencing of products beyond 10 kb in size opens new opportunities in genome mapping, resolution of copy numbers, difficult genome regions and sequencing novel (pathogenic) microorganisms.

striking advantage of this technology is the enormous read lengths which are potentially achievable, the very small size of the system (virtually a large USB stick) and a polymerase-free, single molecule sequencing approach able to detect even base modifications. While common next-generation-sequencing technologies have read lengths of about 100-300 bp, Nanopore sequencing technically allows 100-1000-fold longer

reads (achieving up to > 100,000 bp). This allows the resolution of complex gene regions. Our Division has been selected to participate in the early testing phase of this technology in 2015 and is currently working on applications of Nanopore sequencing to repetitive genes (e.g. *LPA* or *MUC* genes) and the establishment of single molecule haplotyping in large copy number variants.



Fig 6: Team of Genetic Epidemiology

Selected Publications

Association between apolipoprotein A-IV concentrations and chronic kidney disease in two large population-based cohorts: results from the KORA studies

Stangl S*, Kollerits B*, Lamina C, Meisinger C, Huth C, Stöckl A, Dähnhardt D, Böger CA, Krämer BK, Peters A, Kronenberg F
JOURNAL OF INTERNAL MEDICINE. 2015;278: S.410-423

A genome-wide association meta-analysis on apolipoprotein A-IV concentrations

Lamina C*, Friedel S*, Coassin S, Ruedi R, Youssi NA, Seppälä I, Gieger C, Schönherr S, Forer L, Erhart G, Kollerits B, Marques-Vidal P, Ried J, Waeber G, Bergmann S, Dähnhardt D, Stöckl A, Kiechl S, Raitakari OT, Kähönen M, Willeit J, Kedenko L, Paulweber B, Peters A, Meltinger T, Strauch K, Lehtimäki T, Hunt SC, Vollenweider R, Kronenberg F
HUMAN MOLECULAR GENETICS. 2016; 25: S. 3635-3646

The N14 anti-afamin antibody Fab: a rare VLI1 CDR glycosylation, crystallographic re-sequencing, molecular plasticity and conservative versus enthusiastic modelling

Naschberger A, Fümrohr BG, Lenac Rovis T, Malic S, Scheffzek K, Dieplinger H, Rupp B
ACTA CRYSTALLOGRAPHICA SECTION D. 2016; 72: S. 1267-1280

HaploGrep 2: Mitochondrial Haplogroup Classification in the Era of High Throughput Sequencing

Weissensteiner H, Pachner D, Kloss-Brandstaetter A, Forer L, Specht G, Bandelt HJ, Kronenberg F, Salas A, Schönherr S
NUCLEIC ACIDS RESEARCH. 2016; 44: W58-W63

mtDNA-Server: next-generation sequencing data analysis of human mitochondrial DNA in the cloud

Das S*, Forer L*, Schönherr S*, Sidore C, Locke AE, Kwong A, Vrieze SI, Chew EY, Levy S, McGue M, Schlessinger D, Stambolian D, Loh PR, Iacono WG, Swaroop A, Scott LJ, Cucca F, Kronenberg F, Boehnke M, Abecasis GR*, Fuchsberger C*
NATURE GENETICS. 2016; 48: S. 1284-1287

Reference-based phasing using the Haplotype Reference Consortium Panel

Loh PR, Danecek P, Palamara PF, Fuchsberger C, Reshef A, Finucane K, Schoenherr S, Forer L, McCarthy S, Abecasis GR, Durbin R, Price L
NATURE GENETICS. 2016; 48: S. 1443-1448

Influence of DNA extraction methods on relative telomere length measurements and its impact on epidemiological studies

Raschenberger J*, Lamina C*, Haun M, Kollerits B, Coassin S, Boes E, Kedenko L, Köttgen A, Kronenberg F
SCIENTIFIC REPORTS. 2016; 6: S. 25398

Association of relative telomere length with cardiovascular disease in a large chronic kidney disease cohort: the GCKD study

Raschenberger J*, Kollerits B*, Titze S, Köttgen A, Bärthlein B, Ekici AB, Forer L, Schönherr S, Weissensteiner H, Haun M, Wanner C, Eckardt KU, Kronenberg F
ATHEROSCLEROSIS. 2015; 242: S. 529-534

Multinational Assessment of Accuracy of Equations for Predicting Risk of Kidney Failure: A Meta-analysis

Tangri N, Grams ME, Levey AS, Coresh J, Appel LJ, Astor BC, Chodick G, Collins AJ, Djurdjev O, Elley CR, Evans M, Garg AX, Hallan SI, Inker LA, Ito S, Jee SH, Kovesdy CP, Kronenberg F, Heerspink HJ, Marks A, Nadkarni GN, Navaneethan SD, Nelson RG, Titze S, Sarnak MJ, Stengel B, Woodward M, Iseki K
JAMA. 2016; 315: 164-174

Selected Funding

- "Structure-function investigations of human afamin", FWF Bernhard Rupp
- Extension of the "German Chronic Kidney Disease Study"; German BMBF and KfH Stiftung; Florian Kronenberg
- "Center of Common Disease Genetics", NIH Subaward agreement with the University of Michigan (Goncalo Abecasis); Florian Kronenberg (together with Christian Fuchsberger, Lukas Forer and Sebastian Schönherr)

Collaborations

- Goncalo Abecasis, Center of Statistical Genetics, University of Michigan, Ann Arbor, USA
- Enis Afgan, Ruder Bošković Institute Zagreb, Croatia & Johns Hopkins University, Baltimore, USA
- Steven C. Hunt, Cardiovascular Genetics Division, University of Utah, Salt Lake City, USA
- Institute of Epidemiology, Helmholtz Zentrum München, Neuherberg, Germany
- Günther Specht, Department of Database and Information Systems; Institute of Computer Science, University of Innsbruck, Innsbruck, Austria
- Matthew Bowler, Synchrotron Diffraction, EMBL Grenoble, France
- Kai-Uwe Eckardt, Department of Nephrology and Hypertension, University of Erlangen-Nürnberg, Erlangen, Germany
- Nicole Probst-Hensch, Swiss Tropical and Public Health Institute, Basel, Switzerland
- Anna Köttgen, Division of Genetic Epidemiology, University of Freiburg, Freiburg, Germany
- Arif B. Ekici, Institute of Human Genetics, University of Erlangen-Nürnberg, Erlangen, Germany

Corefacilities

Sequencing & Genotyping Core Facility

The Sequencing & Genotyping Core Facility owns state-of-the-art equipment for Sanger sequencing, high throughput genotyping and qPCR and fragment analysis:

- Sequenom MassARRAY4 MALDI-TOF System: multiplex genotyping and methylation analysis
- QuantStudio 6 Flex System: large scale genotyping and qPCR
- 3130xl System: Sanger sequencing and fragment analysis
- Fragment Analyzer: automated, high-throughput capable fragment analysis for NGS library quality assessment
- 8 and 96 channel TECAN pipetting robots for large pipetting jobs and automated sample normalization
- On cooperative basis: Nanopore Sequencing using the ONT MiniION system

Human Genetics



Head of Division:
Univ.-Prof. DDr. Johannes Zschocke

Contact:
Peter Mayr Straße 1/1
6020 Innsbruck

Humgen@i-med.ac.at
Phone: +43 512 9003 70501
Fax: +43 512 9003 73510
www.humgen.at

Research Branch (ÖSTAT Classification)

301301, 301304, 301307,
302064, 304002

Keywords

Human genetics, molecular genetics, cytogenetics, mitochondrial genetics, transcript analysis, tumour disposition syndromes, genetic skin diseases, metabolic medicine, cancer genetics

Research Focus

- Genetic causes of rare diseases, including:
 - Inherited connective tissue disease
 - Inherited metabolic diseases
 - Genetic disease of the teeth and periodontal tissue
 - Developmental disorders, intellectual disability and dysmorphic syndromes
- Genetic causes of tumours and tumour dispositions, including:
 - Inherited cancer disposition syndromes
 - Breast and ovarian cancer
 - Hamartomatous tumours
 - Cytogenetics of haematological malignancies
- Membrane lipid metabolism of organelles and cells
- Transcription and transcript processing of nuclear genes, in particular splice mechanisms
- New methods of genetic laboratory diagnosis, mutation databases, molecular genetic quality control

General Facts

The primary aim of the Division of Human Genetics is clarifying the genetic determinants of health and disease in humans, with special focus on rare diseases that are inherited as monogenic traits, and on genetic variants that have a major impact on human biology and substantial disease relevance. This aim is achieved by combining comprehensive patient services and expertise in clinical genetics, molecular genetics and cytogenetics with basic research. The institute includes the Centre for Medical Genetics Innsbruck which provides medical genetic services for Western Austria with extensive outpatient clinics and inpatient consultation in Innsbruck and several regional hospitals. The diagnostic laboratories cover all relevant methods for DNA, RNA, and chromosome analysis including classical cytogenetics, fluorescence-in-situ hybridization (FISH), DNA-Array (molecular karyotyping), tumour cytogenetics, Sanger

sequencing for a large number of individual genes, massively parallel (“next generation”) sequencing - both panel and clinical exome -, multiplex-ligation-dependent probe amplification (MLPA), methylation and imprinting analyses, fragment length typing and Southern Blot for microsatellite repeat analyses, and others. Due to the close link with the large basic research unit, interesting observations or unclarified cases may be directly transferred into further investigations on a research basis. The diagnostic laboratories are equipped for a wide range of relevant cell biology techniques, in particular DNA and RNA analyses and the functional analysis of genetic alterations. Special research foci are on the metabolism of cardiolipins and other membrane lipids of organelles and cells, as well as connective tissue diseases and the intracellular processing of extracellular matrix proteins. The division is dedicated to interdisciplinary collaboration and is happy to carry out both diagnostic tests and research investigations for a large number of hospital centres in Innsbruck and elsewhere.

Research

Periodontal Ehlers-Danlos Syndrome and other Inherited Connective Tissue Diseases

Johannes Zschocke, Albert Amberger
Ehlers-Danlos Syndromes (EDS) denote a group of inherited connective tissue disorders characterized by joint hypermobility, skin hyperelasticity and fragility of various tissues. It is mostly caused by deficiencies of different collagens or other causes of disturbed processing or assembly of extracellular matrix proteins. The 2017 International Classification of the Ehlers-Danlos syndromes, recently published with important contributions from Innsbruck, distinguishes 13 subtypes based on the clinical features and involving various different pathomechanisms. The molecular basis of several EDS subtypes has been elucidated in Innsbruck. Recently, clinicians and scientists from Human Genetics, Dentistry and Virology at the MUI, in collaboration with Swedish, French, American, and UK colleagues, identified that the previously disputed periodontal form of Ehlers-Danlos syndrome (pEDS) is a specific condition caused by heterozygous missense mutations in C1R or C1S. The defining clinical feature of pEDS is rapidly progressive periodontitis and tooth loss at a young age; additional symptoms include lack of attached gingiva, pretibial hyperpigmentation, skin and vascular fragility, easy bruising, and variable musculoskel-

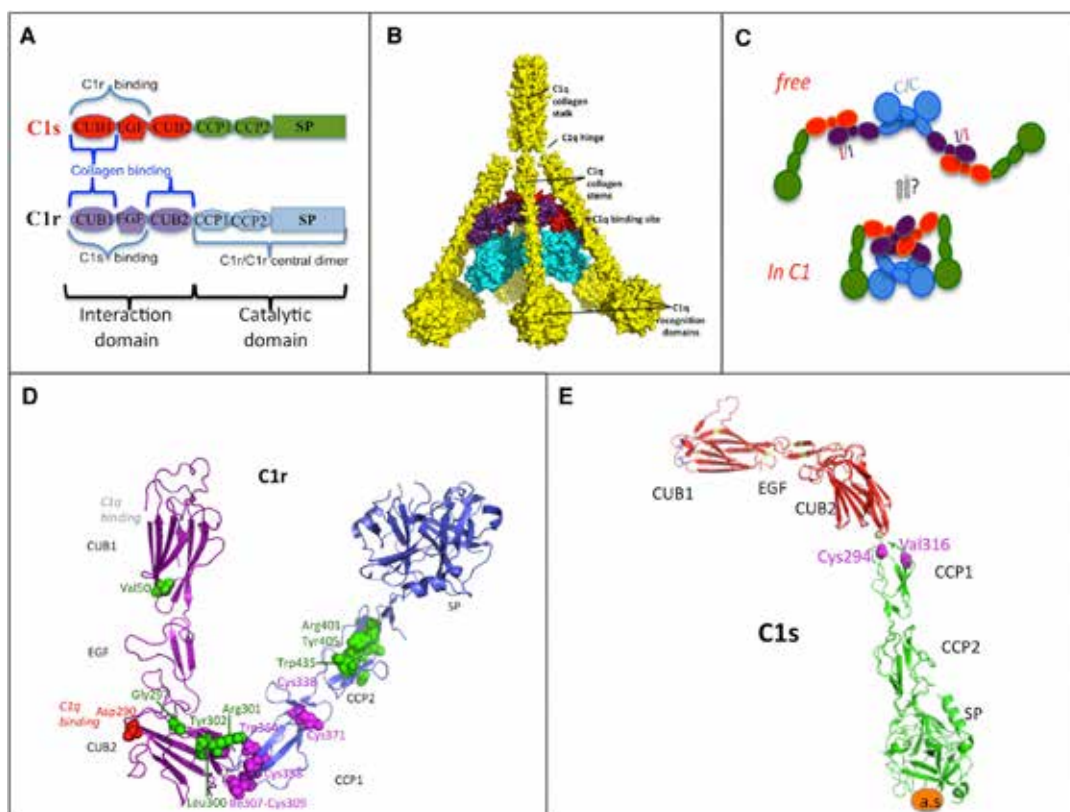

© American Journal of Human Genetics, 2016

Fig. 1: C1r and C1s Structure

A) Modular structure of C1r and C1s and main binding sites to assemble C1. The CUB domain (for complement C1r/C1s, uEGF, BMP1) is a structural motif of approximately 110 residues found almost exclusively in extracellular and plasma membrane-associated proteins. The EGF-like domain is an evolutionary conserved protein domain, which derives its name from the epidermal growth factor where it was first described. It comprises about 40 amino acid residues with six cysteines that form characteristic intra-domain disulfide bonds (1-3, 2-4, and 5-6). CCP (Complement Control Proteins) domains are also termed Sushi domains or Short Consensus Repeats and contain about 60 amino acid residues, each with 4 conserved cysteines that form intradomain disulfide bonds (1-3 and 2-4). These domains are involved in interaction between subunits of proteins and between proteins. The Serine Protease (SP) domains are mostly catalytic domains evolutionary related to the trypsin-chymotrypsin enzymes. The same color code is used for the domains throughout the figure.

B) C1q (yellow) is a hexamer of heterotrimers that contains in its cone the main protease interfacial domains that are crucial for C1r/C1s tetramer assembly. Each heterotrimer (A, B, C chains) contains a protease binding site in its collagen stem and a C-terminal globular recognition domain. This incomplete C1 model includes two copies each of C1r and C1s interaction domains (violet, red) and two copies of C1r catalytic domains (blue).

C) Schematic view of the main protease conformational changes during C1 assembly, with strong bending between the interaction and catalytic domains. The central C1r/C1r interface (C/C, blue) involves C1r CCP1 and SP head to tail interactions.

D and E) Mapping the C1r and C1s variants on 3D structure models. The wild-type residues affected by variants that cause pEDS are shown in colored spheres. The homologous modules are about the same size in the two proteases, which are shown at a different scale.

(reprinted from Kapferer-Seebacher et al., American Journal of Human Genetics 2016;99:1005-14)

etal symptoms.

The findings open a novel connection between the inflammatory classical complement pathway and connective tissue homeostasis. C1R and C1S code for components of the complement complex C1 which upon activation triggers the classical complement cascade to destroy invading microorganisms and initiate defense mechanisms. Complete loss of C1r or C1s caused by homozygous C1R or C1S null mutations causes a lupus-erythematosus-like syndrome with increased susceptibility to infections and increased risk of developing autoimmune diseases. C1r and C1s have an identical domain structure characterized by

CUB1-EGF-CUB2-CCP1(Sushi)-CCP2(Sushi)-SP(serine protease) (Figure pEDS-1). They associate as a tetramer that binds to a bouquet-like structure made of six C1q subunits to form the C1 complex. Each C1q subunit is a heterotrimer of A, B, and C chains which forms a collagen-like stem (Figure pEDS-2). Upon binding of C1q to appropriate targets such as antigen-antibody complexes, C1r is auto-activated by cleavage and can then cleave C1s to form the active C1 esterase. This enzyme can now cleave C4 and C2 to form the classical pathway C3 convertase. pEDS results from specific classes of heterozygous mutations in C1R and C1S. The mechanism of pathogenesis of these mutations differs from homozygous loss of

function of these genes and from loss of the C1 esterase inhibitor.

We have now embarked on an international collaborative research project jointly funded by Austria and France to elucidate the pathomechanism of pEDS. The study will involve the systematic characterization of the clinical presentation and disease complications in all available individuals with heterozygous C1R or C1S gain-of-function mutations. Intracellular localization, modification and activation of complement 1 as well as of collagen and other ECM proteins will be investigated as the exact processes are not fully understood and may be directly or indirectly disturbed by pEDS mutations. It is to be expected that the project will not

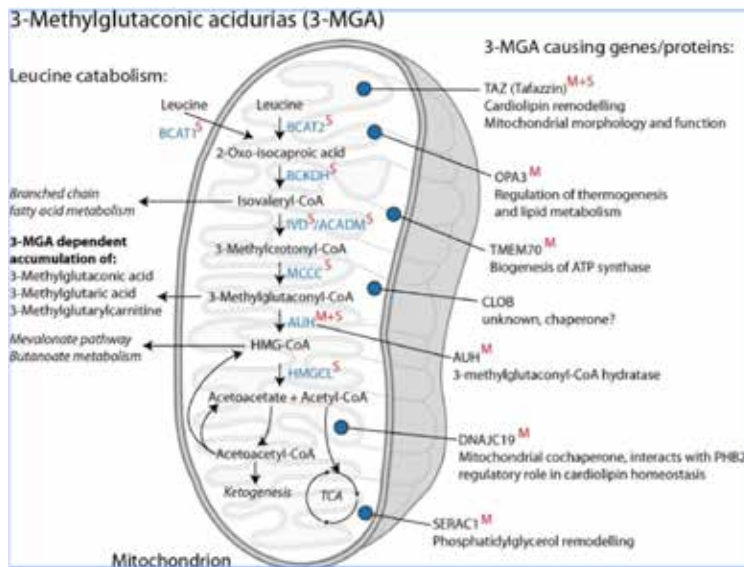

Fig.2: Mitochondrial leucine catabolism is affected by 3-methylglutaconic aciduria related genetic mutations: Leucine catabolic enzymes are shown in blue colour. All depicted proteins are localized to mitochondria, except for the cytosolic BCAT1. Evidence of membrane association (M) or soluble forms (S) is shown in red letters.

only shed light on the specific pathogenesis of pEDS but will also help to delineate the disease-causing mechanisms in other EDS subtypes and connective tissue pathologies.

Membrane Lipid Metabolism of Organelles and Cells

Markus Keller, Johannes Zschocke

Problem: A major unsolved problem connected with human metabolic diseases is that many clinically relevant metabolic parameters are used for differential diagnosis; however, the underlying pathobiochemical mechanisms for their appearances are frequently elusive. Thus, there is a lack of comprehensive knowledge with respect to structure and regulation of respective metabolic pathways and/or the function of the genes involved.

Background: This is especially the case for 3-methylglutaconic acidurias (3MGAuria), a group of human inherited diseases characterized by the accumulation of 3-methylglutaconic acid (3MGA) in patient plasma and urine. Only in primary 3MGAuria can this accumulation be explained easily via defects in the AUH gene, resulting in the blockage of mitochondrial leucine degradation and the cell's inability to detoxify the 3MGA precursor 3-Methylglutaconyl-CoA (see Fig 2).

However, for a series of other 3MGAuria causing genes there is no pathological rationale explaining this phenotype (e.g. TAZ, OPA3, TMEM70, CLOB, DNAJC19, SERAC1). Still, it is noticeable that those genes ap-

pear to be functionally connected to mitochondrial membranes and phospholipid homeostasis therein, especially regarding a mitochondria exclusive class of phospholipids, the cardiolipins (CL).

Research questions and strategy: Key aim

of our current work is to investigate the interdependency of mitochondrial phospholipid homeostasis in membranes with mitochondrial functioning and its impact of leucine catabolism, in order to elucidate the principal pathological principles of respective 3MGAurias. Important steps towards successfully answering this research question are a) the assembly of a comprehensive patient fibroblast cell line collection for 3MGAurias, b) the generation of stable CRISPR/Cas9 knockout lines for the two 3MGAurias: MEGDEL Syndrome (SERAC1) and Barth Syndrome (TAZ), and c) establishing the methodological LC-MS/MS platform for mitochondrial lipidomics as well as further assays for assessing mitochondrial functions.

Lipidomics platform: Our recently developed LC-MS/MS platform allows us to elucidate, in combination with mathematical modelling techniques, the composition of the mitochondrial cardiolipin composition in very great detail (see Fig. 2). Recorded MS1 data is utilized for quantification of up to ~120 different CL species as well as dozens of monolyso-CL and oxidized CL species. At the same time MS/MS fragment data allows us to compute detailed structural information, acyl chain distributions and lipid molecule symmetry information for each of the quantified CL species; data

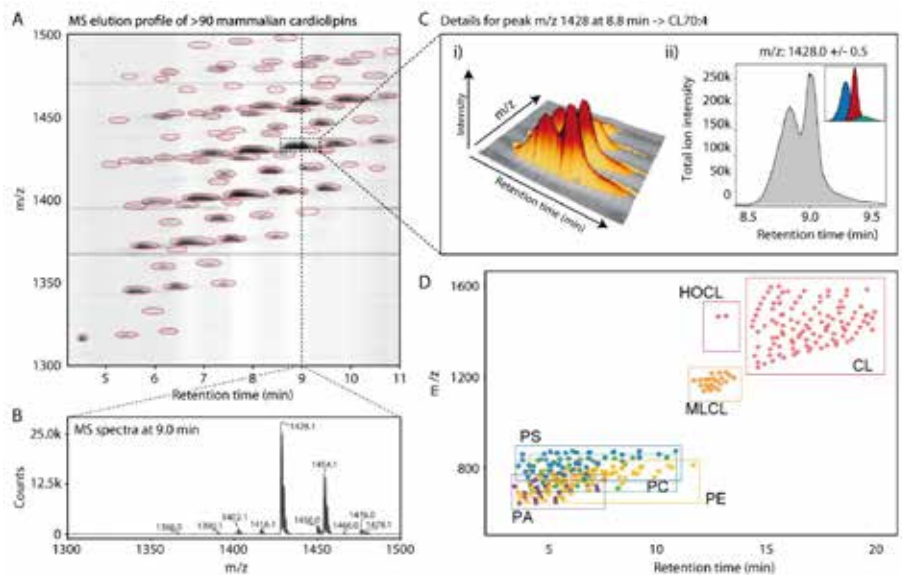

Fig. 3: LC-MS/MS analytical platform for the quantification of cardiolipin profiles. A) 2D representation of the LC-MS elution pattern of more than 120 different cardiolipin species in the mass range of 1300-1500 m/z. B) Full MS1 spectrum at RT=9 min shows different CL classes eluting at the same time, with different m/z. C) Details for example peak m/z 1428, 8.8 min (CL70:4): i) Natural isotope pattern ii) Double peak caused by subspecies. D) Identified phospholipid species: PA: Phosphatidic acid, PC: Phosphatidylcholine, PE: Phosphatidylethanolamine, and PS: Phosphatidylserine (measured with a modified HPLC gradient)

which is therefore ideally suited to study genetic perturbations of mitochondrial phospholipid homeostasis. Additionally this method has already been extended to cover other important phospholipid lipid classes (Fig. 3D).

Cancer Genetics

Katharina Wimmer

This research is strongly associated with the clinical diagnostic lab of the division which offers molecular analyses for the whole spectrum of cancer susceptibility syndromes.

A major aim of the cancer genetics research lab is the development and improvement of diagnostic tools for the identification and classification of mutations. In collaboration with a bioinformatics team at the Johannes Kepler University, Linz, the lab has developed and evaluated a novel bioinformatics tool that is now used in the clinical diagnostic lab for detection of copy number variations in targeted massively-parallel (next generation) sequencing panel data. Furthermore, the lab has long-standing experience with RNA-based assays that substantially increase mutation detection rates in tumour suppressor genes by effectively uncovering splice alterations caused by mutations that either fully escape the detection of gDNA based assays or cannot be readily be classified as deleterious from the analysis of gDNA only. The evaluation of these 'atypical' splice mutations e.g. in the NF1 gene also provides novel insights into the basic mechanisms of splice site definition and inactivation. RNA-based assays also proved pivotal in circumventing diagnostic obstacles that are caused by the presence of pseudogenes e.g. of the mismatch repair gene PMS2.

Future goals: Transfer of experience and knowledge gained with RNA-based mutation analysis in the Sanger sequencing era into the massive parallel sequencing era. This will involve the evaluation of 'atypical' splice mutations with the aim to deduce commonly applicable rules for the selection of unclassified variants (i.e. variants of unknown pathogenicity) likely to affect mRNA splicing for further mRNA analyses.

A second aim of this research lab is the genetic and clinical characterization of a rare autosomal recessive cancer susceptibility syndrome caused by biallelic mutations in one of the four DNA mismatch repair (MMR) genes MLH1, MSH2, MSH6, and PMS2. This condition is denoted "Constitutional mismatch repair deficiency" (CMMRD) and shows clinical overlap with other cancer susceptibility syndromes, notably neurofibromatosis type 1 (NF1) and

polyposis syndromes. It has only recently been recognized as a distinct childhood cancer susceptibility syndrome. As such there is still a lack of knowledge on the natural history of this syndrome.

Major achievements: Making the molecular diagnosis in a number of patients the lab substantially contributed to delineation of the syndrome with regard to tumour spectrum and non-neoplastic features. This led to the development of clinical diagnostic criteria proposed by a European consortium under the leadership of our lab.

Future goals: To uncover pathogenetic mechanisms, in particular secondary somatic mutations, underlying the development of neoplastic and non-neoplastic features in CMMRD patients, as well as to evaluate clinical data on CMMRD patients in close collaboration with the European consortium, both with the ultimate goal to improve the management of CMMRD patients.

Selected Publications

High prevalence of BRCA1 stop mutation c.4183C>T in the Tyrolean population: implications for genetic testing.

Pölsler L, Fiegl H, Wimmer K, Oberaigner W, Amberger A, Traunfellner P, Morscher RJ, Weber I, Fauth C, Wernstedt A, Sperner-Unterwieser B, Oberguggenberger A, Hubalek M, Marth C, Zschocke J. EUROPEAN JOURNAL OF HUMAN GENETICS: 2016; 24: S. 258-262

PMS2 inactivation by a complex rearrangement involving an HERV retroelement and the inverted 100-kb duplicon on 7p22.1.

Vogt J, Wernstedt A, Ripperger T, Pabst B, Zschocke J, Kratz C, Wimmer K. EUROPEAN JOURNAL OF HUMAN GENETICS: 2016; 24: S. 1598-1604

Periodontal Ehlers-Danlos Syndrome Is Caused by Mutations in C1R and C1S, which Encode Subcomponents C1r and C1s of Complement.

Kapferer-Seebacher I, Pepin M, Werner R, Aitman TJ, Nordgren A, Stoiber H, Thielens N, Gaboriaud C, Amberger A, Schossig A, Gruber R, Giunta C, Bamshad M, Björck E, Chen C, Chitayat D, Dorschner M, Schmitt-Egenolf M, Hale CJ, Hanna D, Hennies HC, Heiss-Kisielewsky I, Lindstrand A, Lundberg P, Mitchell AL, Nickerson DA, Reinstein E, Rohrbach M, Romani N, Schmuth M, Silver R, Taylan F, Vandersteen A, Vandrovцова J, Weerakkody R, Yang M, Pope FM; Molecular Basis of Periodontal EDS Consortium., Byers PH, Zschocke J. AMERICAN JOURNAL OF HUMAN GENETICS: 2016; 99: S. 1005-1014

17-Hydroxysteroid dehydrogenase type 10 predicts survival of patients with colorectal cancer and affects mitochondrial DNA content.

Amberger A, Deutschmann AJ, Traunfellner P, Moser P, Feichtinger RG, Kofler B, Zschocke J. CANCER LETTERS: 2016; 374: S. 149-155

Mitochondrial 3-hydroxy-3-methylglutaryl-CoA synthase deficiency: urinary organic acid profiles and expanded spectrum of mutations.

Pitt JJ, Peters H, Boneh A, Yapfite-Lee J, Wieser S, Hinderhofer K, Johnson D, Zschocke J. JOURNAL OF INHERITED METABOLIC DISEASE: 2015; 38: S. 459-466

Collaborations

- Messiaen, Ludwine, University of Alabama at Birmingham, Birmingham, AL, USA
- Kratz, Christian, Department of Pediatric Hematology & Oncology, Hannover Medical School, Hannover, Germany
- Povysil, Gundula, Institute of Bioinformatics, Johannes Kepler University, Linz, Austria

Biochemical Pharmacology



Vice Head of Division (interim):
ao. Univ.-Prof. Dr. Manfred Grabner

Contact:

Peter Mayr Straße 1
6020 Innsbruck

Manfred.Grabner@i-med.ac.at
Phone: +43 512 9003 70407
Fax: +43 512 9003 73440
www.i-med.ac.at/ibp

Head of Division (interim):
Univ.-Prof. Dr. Hans-Günther Knaus

Hans.G.Knaus@i-med.ac.at
Phone: +43 512 9003 70440

Research Branch (ÖSTAT Classification)

301206, 301902, 106002,
106023, 106006

Keywords

Pharmacology, immunology, biochemistry,
molecular biology, biophysics

Research Focus

- Grabner's lab focusses on structural and functional studies of multiple components of the skeletal muscle excitation-contraction (EC) coupling machinery, using zebrafish and mouse as model organisms. Another focus of this lab is the role of Ca^{2+} -activated Cl^- channels in skeletal muscle EC coupling.
- Sandra Santos-Sierra: Pharmacological modulation of the innate immune response. Our research interests focus on understanding the human innate immune response in inflammatory diseases, in particular the activity of phagocytes and the signaling processes involved. Based on this knowledge we intend to develop novel substances that may be specifically applied to modulate the immune activity (stimulation or down-regulation).

General Facts

Until his retirement in 2009, Hartmut Glossmann was director of the Division of Biochemical Pharmacol-

ogy. In October 2009, Hans-Günther Knaus was appointed interim director. The Division of Biochemical Pharmacology is substructured into two largely independent research groups, headed by Sandra Santos-Sierra and Manfred Grabner. A detailed description of the research topics is given below.

Grabner Lab

The basic mechanism of skeletal muscle contraction is driven by release of Ca^{2+} from SR (sarcoplasmic reticulum) stores. Two distinct Ca^{2+} channels interact with each other in this complex process called excitation-contraction (EC) coupling. These are the voltage-gated L-type Ca^{2+} channel or dihydropyridine receptor (DHPR) of the surface membrane and the intracellular Ca^{2+} release channel or ryanodine receptor (RyR1) of the SR. Our main research aim is to elucidate the structure-function relationship of this fascinating bidirectional Ca^{2+} channel cross-talk in skeletal muscle. We succeeded in fine-mapping the domains of the DHPR α_{1S} and $\beta_{1\alpha}$ subunits that are crucial for this protein-protein signal transduction. Besides structure-functional domain mapping, our research is devoted to investigate the role of Ca^{2+} through skeletal muscle DHPR, which is not (directly) involved in EC coupling.

Sandra Santos-Sierra

The innate immune system plays a crucial role not only in fighting infections, but also in numerous diseases and pathological conditions, including cancer. Toll-like receptors

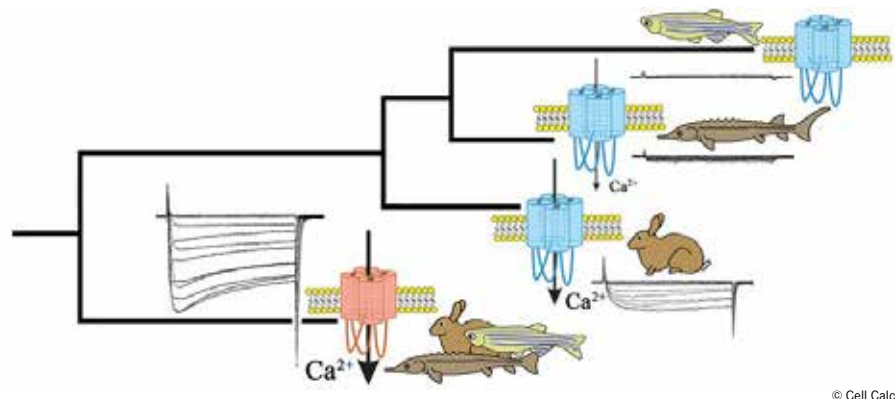

© Cell Calcium

*Fig. 1: Due to the lack of evolutionary pressure (in species with Ca^{2+} -independent excitation-contraction coupling) skeletal muscle DHPR α_{1S} Ca^{2+} conductivity gradually reduced as evolution progressed. Interestingly, the DHPR of the early ray-finned fish sterlet (*Acipenser ruthenus*) is phylogenetically positioned above the mammalian rabbit DHPR α_{1S} which retained robust Ca^{2+} conductivity, but below the euteleost zebrafish DHPR α_{1S} which completely lost Ca^{2+} conductivity. Remarkably, our results revealed that sterlet DHPR α_{1S} still retained the Ca^{2+} conductivity but influx is significantly reduced compared to rabbit. The cardiac DHPR α_{1C} of all 3 species has an identical high Ca^{2+} conductivity.*

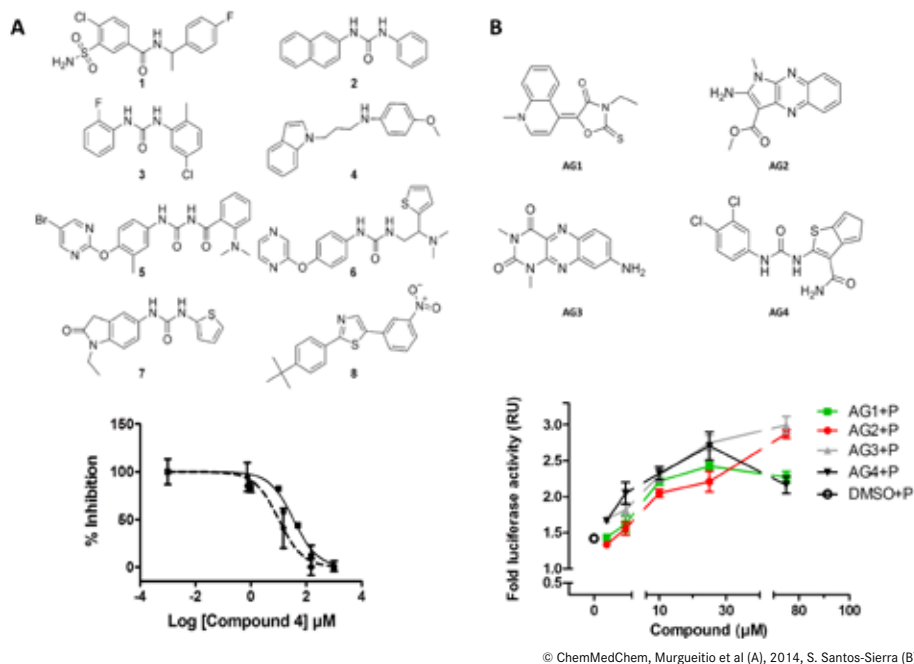

Fig. 2: A. Small-molecules TLR2 antagonists. The inhibitory concentration lies in the low micromolar range and it was determined as the inhibition in TNF α production by human monocytes after TLR2 stimulation. B. Small-molecules TLR2 agonists. The compounds synergize with known TLR2 ligands (as shown in luciferase experiments) pointing to a possible allosteric binding site in the receptor.

(TLRs) are major components of this system. They recognize pathogens via ligation of pathogen-associated molecular patterns (PAMPs), likewise they bind some host derived ligands resulting from tissue damage (DAMPs). Thus, the central role of TLRs in various inflammatory processes and in sepsis is well recognized. For this reason, the discovery of substances with modulatory activity on TLR signalling may have important implications in therapy of a broad spectrum of pathologies linked to inflammation.

Research

Grabner Lab

Recent Major Achievements:

In a recent study we investigated the phylogenetic disappearance of DHPR Ca²⁺ influx in skeletal muscle. We found that towards the development of ray-finned fishes – which are phylogenetically advanced compared to mammals – the DHPR Ca²⁺ conductance “fades out”, while the final “turn off” needed the 3rd round of genome duplication (Ts3R), on the basis of euteleost fishes (Schrötter/Dayal & Grabner, 2017). In cooperation with the lab of Prof. Flucher (Department of Physiology) we described two distinct voltage-sensing DHPR domains which are responsible for

DHPR voltage-sensing and flow activation (Tuluc *et al.*, 2016). Finally we could show that DHPR Ca²⁺ influx into mammalian skeletal muscles – which has been under investigation for more than half a century – is (very surprisingly) an evolutionary remnant (Dayal *et al.*, 2017, in revision)

Future Goals:

In our present FWF grant (P27392-B21) we explore molecular regions of the essential DHPR β_{1a} subunit responsible for DHPR tetrad formation.

Our research also focuses on the role of Ca²⁺-activated Cl⁻ channels in the skeletal muscles of zebrafish, which are activated during EC coupling (MCBO, W1101-B12, funded by FWF). In euteleost fish (which have the highest evolved skeletal muscles) the Ca²⁺-activated Cl⁻ channel plays a role in shaping the muscle action potential.

Santos-Sierra Lab

Toll-like receptor 2 (TLR2) recognizes bacterial di- and tri-acylated lipopeptides and also some host endogenous ligands such as HMGB1 or hyaluronan. We have identified several compounds, synthetic small-molecules, which are bona fide TLR2 ligands. The novel compounds were retrieved from a combined *in silico/in vitro* screening for

their potential to bind TLR2 in HEK293 cells overexpressing the receptor and bearing an NF κ B-dependent reporter construct.

Two groups of compounds were selected and their mechanism of action is under characterization: First, TLR2-antagonists which bind the TLR2/1 and TLR2/6 heterodimers at the lipopeptide ligand (Pam3CSK4) binding site, as indicated by molecular modeling (Fig. 2A); Second, TLR2-agonists whose binding mode is structurally not defined yet, as these compounds have synergistic activity with other TLR2 ligands (Fig. 2B). The activity of the different compounds in mouse and human immune cells has been tested and proof of their *in vivo* activity is under way.

In order to modulate TLR activity, small molecules show better properties than natural TLR2 ligands (e.g. their synthesis is cheaper and they can be purified to clinical grade). Consequently, the novel TLR2-antagonists may be applied in pathologies where TLR2 over-activation leads to an increased inflammatory response. On the other hand, TLR2-agonists may be used as adjuvants in those settings in which the immune system does not respond.

Selected Publications

Two distinct voltage-sensing domains control voltage sensitivity and kinetics of current activation in Ca(V)_{1.1} calcium channels

Tuluc, Petronel, Benedetti, Bruno, de Bagneaux, Pierre Coste, Grabner, Manfred, Flucher, Bernhard E., JOURNAL OF GENERAL PHYSIOLOGY: 2016; 147: S. 437-449

Selected Funding

- 2014-recent: Austrian Science Fund (FWF) P27392-B21; Structure – Functional Link in the DHPR β_{1a} Subunit for Tetrad Formation and Skeletal Muscle Motility.
- 2005-recent: Graduate Program Molecular Cell Biology and Oncology (MCBO) at the Medical University Innsbruck funded as W1101-B12 by Austrian Science Fund (FWF); (B. Flucher, Speaker).

Collaborations

- Prof. Clara Franzini-Armstrong: Department of Cell and Developmental Biology, Univ. of Pennsylvania, Philadelphia, U.S.A
- Prof. Dr. Francesco Zorzato: Department of Life Sciences and Biotechnologies, University of Ferrara, Italy
- Dr. Werner Melzer: Department of Molecular Physiology and Biophysics, Universität ULM, Deutschland

Molecular and Cellular Pharmacology



Head of Division:
Univ.-Prof. Dr. Hans-Günther Knaus

Contact:
Peter Mayr Straße 1
6020 Innsbruck

Hans.G.Knaus@i-med.ac.at
Phone: +43 512 9003 70440
Fax: +43 512 9003 73440
www.i-med.ac.at/molpharm

Research Branch (ÖSTAT Classification)

301406, 301206

Keywords

Ion channels, protein biochemistry, antibodies, proteomics, immunoprecipitation

Research Focus

Our research unit focuses on certain key aspects of voltage- and ligand-gated ion channels. We are interested in the subunit composition of several ion channel families as well as their cellular and subcellular distribution. In addition, our research aims to identify the respective ion channel nanodomains via immunoprecipitation experiments as well as via high-sensitivity sequencing by mass spectrometry. We also investigate the distribution and subunit composition of ion channels (mostly voltage-gated and calcium-activated potassium channels) in human brain regions.

General Facts

Our research unit is quite small in terms of associated personnel, resources and associated lab space. We reside on the

ground level of the Pharmacology/ Genetics building in Peter-Mayr Strasse 1 in approx. 110m² of lab- and office space. The majority of equipment and facilities is shared with other Pharmacology units (Division for Biochemical Pharmacology or the Institute of Pharmacology). Our unit employs a total of 5 people: The division head, a part-time administrator, 2 research assistants (1 out of the 2 researchers is on maternity leave since almost 2 years) and an animal care keeper. Both research assistants and the division head are MDs and also have clinical duties especially related to the institutional ethics committee.

Research

Our lab is primarily interested in investigating the composition, microenvironment and distribution of various ion channels, in particular several classes of potassium and TRPV channels. All these channels appear to associate with other molecular components in complexes, so-called 'microdomains'. We aim to establish the composition of these ion channel complexes by use of various detergent solubilisation protocols, immunoprecipitation experiments and sequencing of isolated ion channel complexes through mass spectrometry.

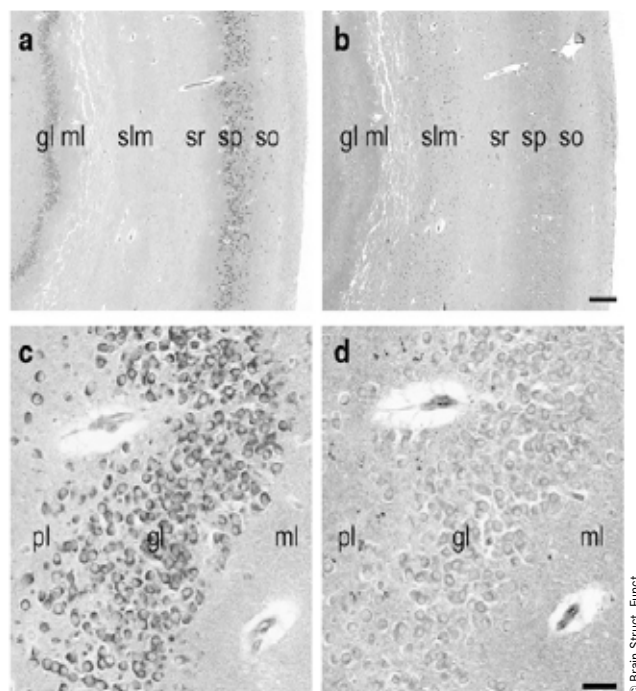

Fig. 1: Comparison of SK2-LI obtained with antibodies directed against the C-terminal and the N-terminal region of the SK2 peptide. Adjacent sections of SK2-LI detected with ANTI-CSK2 and Anti-NSK2. In hippocampus, SK2-LI was detected in molecular layer and in strata oriens and radiatum of CA1 (a, b). In granule cell layer, SK2-LI could be detected mainly in the plasma membrane (c, d).

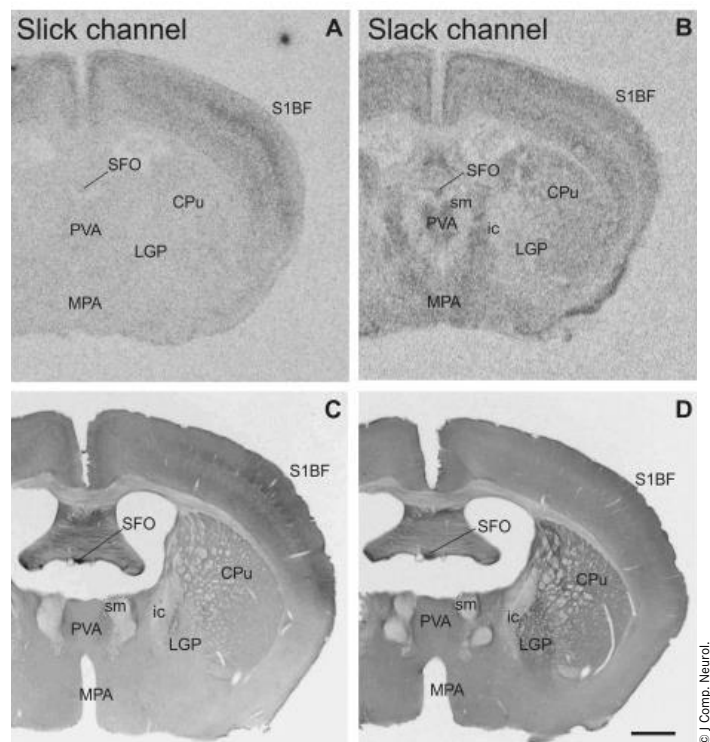

Fig. 2: Overview of Slick and Slack channel mRNA and protein labelling in mouse brain (Bregma -0.5 mm). **A,B:** Representative autoradiographs of Slick and Slack channel *in situ* hybridization. **C,D:** Corresponding areas of Slick and Slack channel immunolabelling. **A–D:** Particularly strong *in situ* hybridization and immunohistochemical signals for Slick and Slack channel expression were detected in the subfornical organ. **D:** Slack channel immunostaining was also evident in the lateral globus pallidus. Scale bar 5,000 μ m.

Distribution of Various Potassium Channels in Human Brain.

Hans-Günther Knaus

We investigated the distribution and expression of SK2 channels (small conductance calcium activated potassium channels) in human brain by Western blot analysis and immunohistochemistry. Immunoblot analysis of human brain indicated expression of four distinct SK2 channel isoforms: the standard, the long and two short isoforms. Immunohistochemistry in paraffin-embedded post-mortem brain sections was performed in the hippocampal formation, amygdala and neocortex. In hippocampus, SK2-like immunoreactivity could be detected in strata oriens and radiatum of area CA1-CA2 and in the molecular layer. In the amygdala, SK2-like immunoreactivity was highest in the basolateral nuclei, while in neocortex, staining was mainly found enriched in layer V. Activation of SK2 channels is thought to regulate neuronal excitability in brain by contributing to the medium after hyperpolarization. However, SK2 channels are blocked by apamin with a sensitivity that suggests heteromeric channels. These expression data of SK2 human isoform b in brain could explain the variability of electrophysiological findings observed with SK2 channels.

Distribution of Slick and Slack Potassium Channels in Mouse Brain.

Hans-Günther Knaus

We have established the distribution and subcellular localization of Slick and Slack channels in the mouse brain through *in situ* hybridization and immunohistochemistry. Both channels were widely distributed and exhibited distinct distribution patterns. However, in some brain regions, their expression overlapped. Intense Slick channel immunoreactivity was observed in processes, varicosities, and neuronal cell bodies of the olfactory bulb, granular zones of cortical regions, hippocampus, amygdala, lateral septal nuclei, certain hypothalamic and midbrain nuclei, and several regions of the brainstem. The Slack channel showed primarily a diffuse immunostaining pattern, and labelling of cell somata and processes was observed only occasionally. The highest Slack channel expression was detected in the olfactory bulb, lateral septal nuclei, basal ganglia, and distinct areas of the midbrain, brainstem, and cerebellar cortex. In addition, comparing our data obtained from mouse brain with a previously published study on rat brain revealed some differences in the expression and distribution of Slick and Slack channels in these species.

Major Achievements:

Complete panels of sequence-directed antibodies against a large number of different ion channel families were characterized. By use of these antibodies, the microdomain environments of some of these ion channels were established.

Future Goal:

To characterize some of these novel interaction partners in terms of their precise function in the respective ion channel complex.

Selected Publications

Differential Distribution of the Sodium-Activated Potassium Channels Slick and Slack in Mouse Brain
Rizzi, Sandra, Knaus, Hans-Guenther, Schwarzer, Christoph, JOURNAL OF COMPARATIVE NEUROLOGY: 2016; 524: S. 2093-2116

Small-Conductance Ca²⁺-Activated Potassium Type 2 Channels Regulate the Formation of Contextual Fear Memory

Murthy, Saravana R. K., Sherrin, Tessi, Jansen, Chad, Nijholt, Ingrid, Robles, Michael, Dolga, Amalia M., Andreotti, Nicolas, Sabatier, Jean-Marc, Knaus, Hans-Guenther, Penner, Reinhold, Todorovic, Cedimir, Blank, Thomas, PLOS ONE: 2015; 10: S. e0127264

Small-conductance calcium-activated potassium type 2 channels (SK2, KCa2.2) in human brain

Willis M, Trieb M, Leitner I, Wietzorrek G, Marksteiner J, Knaus H-G BRAIN STRUCTURE AND FUNCTION: 2016; 10.1007/s00429-016-1258-1

Collaborations

Peter Ruth, Pharmacology, Tuebingen, Germany
Bernd Fakler, Physiology II, Freiburg, Germany

Clinical and Functional Anatomy



Head of Division:
Univ.-Prof. Dr. Erich Brenner, MME

Contact:
Müllerstraße 59
6020 Innsbruck

Erich.Brenner@i-med.ac.at
Phone: +43 512 9003 71121
Fax: +43 512 9003 73112
www.anatomie-innsbruck.at

Research Branch

301102, 301104, 301106,
301107, 301111

Keywords

Clinical Anatomy, Functional Anatomy, Ultrasonography, Medical Education, Inner Ear

Research Focus

- Clinical and Functional Anatomy in collaboration with clinical departments (e.g. Traumatology, Visceral Surgery, Plastic and Reconstructive Surgery, Radiology, etc.)
- Developmental Anatomy of the Inner Ear
- Ultrasound guided blockages of plexus and peripheral nerves
- Ultralow-dose computed tomography
- Neuromonitoring and -modulation
- Anatomical (medical) education

General Facts

Mors Auxilium Vitae – Death aids life. This saying, mounted on a door of the department, aptly characterizes the basic conceptual design and objectives of our group. This means that anatomy is not considered a discipline decoupled from daily medical prac-

tice, but the whole Division's activity is focused on the welfare and health of people. The Division therefore sees its main role in the development, exchange and implementation of clinical and clinically applied anatomy used in research and teaching as a basic science with indirect and direct benefits for patients.

The Division of Clinical and Functional Anatomy is staffed by eleven scientific and ten administrative members.

The Division operates laboratory facilities for histology and immunohistology, an ultrasound laboratory, and an extensive body donation program, both for educational and scientific purposes.

The Division contributes much to the pre-clinical training of future medical practitioners. The broad spectrum of learning activities includes lectures as well as practical exercises. Therefore, also some scientific efforts deal with medical education and the body donation program. Further educational activities include regular courses for the continuing medical education of different medical disciplines. Among them, there are workshops and surgical courses organized in cooperation with the corresponding clinics of the Medical University of Innsbruck and also with international organizations and societies.

Research

Clinical and Functional Anatomy

Research in this field was characterised by intense collaborations with local, national and international clinicians of all kinds (e.g. Traumatology, Visceral Surgery, Plastic and Reconstructive Surgery, Radiology, etc.) ranging from transanal minimal-invasive surgery (the TAMIS project), towards new techniques for bone augmentation. Research in the field of shock-wave therapy resulted in a pioneering paper showing that this therapy could lead to a causal treatment for ischemic spinal cord injury, and showed that the alteration of inflammatory response resulted in reduced calcification in aortic xenografts. A focus that is more anatomical was given to the anterolateral ligament of the knee, the femoral torsion, the insertion footprint of the teres major muscle, the vastus lateralis muscle, and some biomechanical tests, and also to the description of two extremely seldom anatomical variations: a common trunk of the coronary arteries, and a cross-doubled patellar ligament.

Basic research

Basic research dealt with the adipose tis-

sue, where we could resolve some mechanisms of the negative adipogenic effect of weight loss, the proliferation and adipogenic differentiation of adipose derived stem cells. Further research was conducted to predict drug sensitivity using 3D cell culture models, and to study the interaction between cancer cells and immune cells. Additionally, peculiarities of the innervation of the extraocular muscles, and of the ultrastructural and developmental features of the tessellated endoskeleton of sharks and rays were addressed.

Developmental Anatomy of the Inner Ear

In continuation with previous research, recent papers addressed the neurosensory differentiation providing first-hand insights into the fetal development of the vestibular end organs as well as their pattern of innervation, with the aim of contributing towards our understanding of balanced development. Studies on the innervation pattern in the developing ear demonstrated the presence of nerve fibres in the prosensory domain at gestational week (W) 8, followed by afferent synaptogenesis at W 11, thus providing insights into the early assembly of the neural circuit and organization in humans. Investigations of the pre- and post-somatic segments of the human type I spiral ganglion neurons let us assume that the non-myelinated Schwann cells protect these spiral ganglion neurons from further degeneration following dendrite loss. This may give further explanation as to why spiral ganglion neurons can persist as electrically excitable monopolar cells even after long-time deafness.

Ultrasound

Previously existing collaborations resulted in several seminal papers addressing the optimal analgetic block for total knee arthroplasty (TKA), a new technique for pudendal



Fig. 1: Core competencies of the division, internal view. orange: research activities, blue: methods and resources

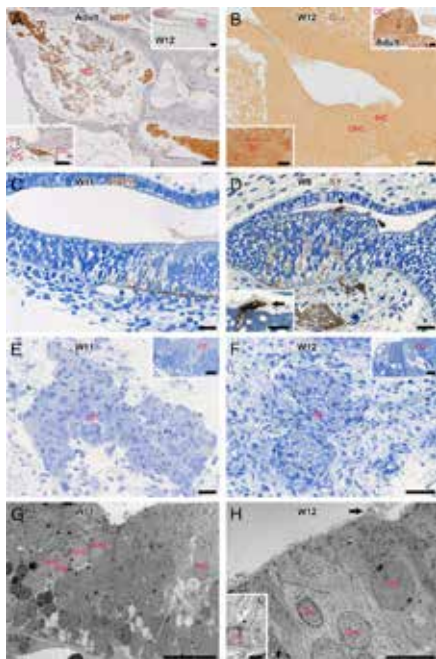

Fig. 2: Radial sections of the developing cochlea at W8, W11, W12 and in adults. (A) MBP-LI (myelin basic protein-like immunoreactivity) in adults within the Rosenthal's canal and in the osseous SG (spiral ganglion) (inset 2). No expression until the end of W12 (inset 1). (B) Glutamate immunostaining by means of postembedding techniques on semithin sections within the OC (organ of Corti) and the SG (inset 1) compared to adult (inset 2). (C) PRPH -LI (peripherin like immunoreactivity) at W11 by means of pre-embedding techniques. (D) At W8, SY (Synaptophysin) immunoreactive fibers are recognized within the GER (Greater Epithelial Ridge) and in the adjacent mesenchyme. Note that an excess of these fibers go first into the acellular matrix of the future tectorial membrane (inset). (E, F) Semithin sections of SGs and organs of Corti (insets) at the beginning of W11 (E) and the end of W12 (F). (G) Overview of the future OC on TEM (Transmission Electron Microscope) level illustrating the precursors of the IHCs (inner hair cells) and OHCs (outer hair cells). (H) Overview of the future organ on TEM level illustrating the precursors of the IHCs and OHCs. At the end of W12, stereocilia of the inner hair (arrow) and pillar cells (inset) are already detectable. Scale bar: 100 μ m (inset A1), 50 μ m (A, E, F; inset A2), 20 μ m (B, C, D, G; insets B2, E), 10 μ m (H; insets B2, D, F), 2 μ m (inset H).

nerve block, which is based on easily recognizable sonoanatomical patterns and probably implies no risk of sacral plexus blockade, a L5 dorsal ramus block; this block can also be used for sonoelastography. Peripheral nerve block for total knee arthroplasty is ideally motor-sparing while providing effective postoperative analgesia. A femoral triangle block guided by internal anatomical structures visible with ultrasonography or midway between the anterior superior iliac spine and the base of the patella provides effective analgesia after medial parapatellar arthroscopy through the integument and

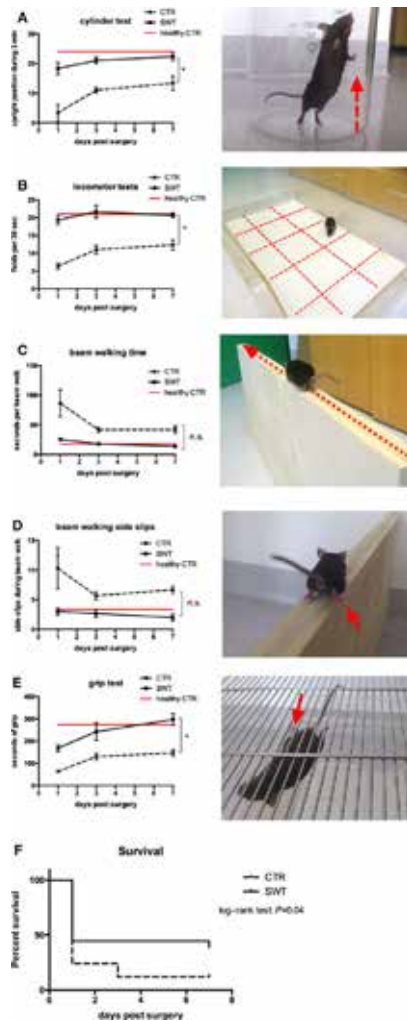

Fig. 3: Shock wave therapy improves functional outcome and survival. A, In the so-called cylinder test, it was counted how often a mouse stood up on its hind limbs during 30 seconds as an indicator of functionality of the lower body. *P<0.05. B, The locomotor test counted the number of fields that a mouse crossed per 30 seconds and was another parameter for mobility, agility, and speed. *P<0.05. C, The beam-walking time was an indicator for speed and coordination. D, The number of slips during a beam walk was the main parameter for the measurement of coordination. Mice still showing paraparesis or even mild paraplegia slipped off the beam more often. E, The grip test measured the time that a mouse was able to hold itself in an inverted position and gave clear information about strength and functionality of the hind limbs. *P<0.05. F, The Kaplan-Meier curve showed that more than two-thirds of the untreated control animals did not survive the first 24 hours. This is due to severe visceral ischemia. A much higher percentage of the shock wave-treated animals survived the study end point of 7 days. CTR indicates control; min, minutes; sec, seconds; SWT, shock wave therapy.

the extraarticular retinaculum of the medial part of the knee. However, it does not alleviate pain deriving from the popliteal nerve branches innervating the intra-articular excision component of TKA. Supplemental

blockade of the popliteal plexus by an obturator nerve block or local anesthetic infiltration of the posterior genicular capsule or local infiltration of the interspace between the popliteal artery and the capsule of the posterior knee is required.

Ultralow-dose computed tomography

New protocols were developed in order to reduce the radiation burden for several areas such as the jaw, and the face.

Neuromonitoring and -modulation

There is a growing interest in this topic, which we addressed by publications on the implantation techniques for pudendal neuromodulation, but also for the intraoperative neuromonitoring of the non-recurrent laryngeal nerve.

Anatomical (medical) education

International collaborations resulted in an innovative review on assessment in anatomy presenting a wide range of possible assessment forms, and investigated the –regrettably low – attitudes of medical students towards the clinical importance of Embryology.

Selected Publications

Development of the innervation of the human inner ear Pechriggl, E. J., Bitsche, M., Glueckert, R., Rask-Andersen, H., Blumer, M. J., Schrott-Fischer, A., Fritsch, H., DEVELOPMENTAL NEUROBIOLOGY: 2015; 75: S. 683-702

Shock Wave Treatment Protects From Neuronal Degeneration via a Toll-Like Receptor 3 Dependent Mechanism: Implications of a First-Ever Causal Treatment for Ischemic Spinal Cord Injury Lobenstein, D., Tepeköylü, C., Kozaryn, R., Pechriggl, E. J., Bitsche, M., Graber, M., Fritsch, H., Semstroth, S., Stefanova, N., Paulus, P., Czerny, M., Grimm, M., Hofheld, J., JOURNAL OF THE AMERICAN HEART ASSOCIATION: 2015; 4: Article e002440

Neurosensory Differentiation and Innervation Patterning in the Human Fetal Vestibular End Organs between the Gestational Weeks 8-12 Johnson Chacko, Lejo, Pechriggl, Elisabeth J., Fritsch, Helga, Rask-Andersen, Helge, Blumer, Michael J. F., Schrott-Fischer, Anneliese, Glueckert, Rudolf, FRONTIERS IN NEUROANATOMY: 2016; 10: Article 111

Ultrasound-Guided Pudendal Nerve Block at the Entrance of the Pudendal (Alcock) Canal: Description of Anatomy and Clinical Technique Bendtsen, T. F., Parras, T., Moriggl, B., Chan, V., Lundby, L., Buntzen, S., Dalgaard, K., Brandsborg, B., Børglum, J., REGIONAL ANESTHESIA AND PAIN MEDICINE: 2016; 41: S. 140-145

The nonrecurrent laryngeal nerve: A clinical anatomic mapping with regard to intraoperative neuromonitoring Korschake, M., Zwierzina, M. E., Pechriggl, E. J., Moriggl, B., Brenner, E., Hörmann, R., Prommegger, R., SURGERY: 2016; 160: S. 161-168

Collaborations

- Abd Ellah M., Department of Diagnostic Radiology, South Egypt Cancer Institute, Assiut University, Egypt
- Aigner F., Pratschke J., Biebl M., Department for General, Visceral and Transplantation Surgery, Charité Universitätsmedizin, Berlin, Germany
- Al-Ekrish A., Al-Shawaf R., Al-Sadhan R., Department of Oral Medicine and Diagnostic Sciences, College of Dentistry, King Saud University, Riyadh, Saudi Arabia
- Atturo F., Department of Neurology, Mental Health and Sensory Organs, Otorhinolaryngologic Unit, Medicine and Psychology, Sapienza, Rome, Italy
- Bauer S., Foditsch E., Janetschek G., Sievert K.-D., Zimmermann R., Department of Urology and Andrology, Paracelsus Private Medical University Salzburg, Austria
- Blumer R., Maurer-Gesek, B., Streicher J., Center of Anatomy and Cell Biology, Medical University of Vienna, Vienna, Austria
- Børglum J., Department of Anesthesia, Zealand University Hospital & Roskilde Hospital, University of Copenhagen, Copenhagen, Denmark
- Brichova H., First Faculty of Medicine, Institute of Histology and Embryology, Charles University Prague, Prague, Czech Republic
- Brodmann M., Clinical Division for Angiology, University Clinics for Internal Medicine, Medical University of Graz, Austria
- Butler A., Dahwan S., Hoang J., Cory M., Zeng K., Butler P., Larry L. Hillblom Islet Research Center, David Geffen School of Medicine, University of California, Los Angeles, US

Neuroanatomy



Head of Division:
Univ.-Prof. Dr. Lars Klimaschewski

Contact:
Müllerstraße 59
6020 Innsbruck

Lars.Klimaschewski@i-med.ac.at
Phone: +43 512 9003 71160
Fax: +43 512 9003 73112
www.neuroanatomy.at

Research Branch (Östat Classification)

301405, 301402, 301403, 301407

Keywords

Cellular neuroscience, FGF receptor signalling and trafficking, fluorescence imaging

Research Focus

Overall interests of our Division are:

- Axotomy-induced neuronal plasticity
- Fibroblast growth factor (FGF) receptor signalling in the nervous system

The Aims of our research are:

- Interference with FGF receptor transport/signalling
- to promote neuronal survival and axonal regeneration
- to control glial proliferation and migration

General Facts

The Division of Neuroanatomy at the Medical University of Innsbruck offers lectures and seminars in functional as well as comparative Neuroanatomy for MD and PhD students. We study fundamental neurobiological phenomena such as axon outgrowth,

nerve regeneration and glial proliferation by mainly applying cellular methods combined with high-resolution imaging.

Research

Our group (Drs Hausott, Valovka, Csanaky, Klimaschewski; PhD students Fogli, Park, Gilbert, Jamsuwan) focuses on the morphological consequences of fibroblast growth factor (FGF) dependent signalling mechanisms in the nervous system. A variety of cell lines, primary neurons, animal models and advanced imaging techniques are used to study the signalling pathways activated by FGF receptors in neurons and glial cells, respectively.

Several FGFs and FGFRs play important roles in brain development and adult brain plasticity following various types of insult to the peripheral or to the central nervous system. Some FGFs mediate tissue repair and regeneration, often by reactivating developmental signalling pathways. FGFRs transduce the effects of other membrane receptors such as NCAM (Neural cell adhesion molecule), L1, and N-cadherin which

are all involved in neuronal plasticity. On the other hand, FGFs bind unrelated receptors, e.g. the Nogo receptor (NgR1), which is involved in axon outgrowth inhibition. Our PhD students investigate whether this crosstalk may be relevant for the regeneration of lesioned sensory neurons (cooperation with Neurobiochemistry). Several mechanisms have evolved to regulate FGF signalling. These range from internalization and degradation of the receptor to modulation of receptor kinase activity by phosphatases and regulation of accessibility of downstream signalling pathways (Fig. 1). Sprouty proteins act as intracellular negative regulators of receptor tyrosine kinases including FGFRs and the nerve growth factor receptor (TrkA). Members of our Division contributed to the elucidation of Sprouty2 function in the lesioned peripheral nervous system by providing evidence that this signalling regulator acts as inhibitor of axonal regeneration *in vitro* and *in vivo*. Our data corroborate the functional significance of the ERK pathway (extracellular signal-regulated kinases) for axon elongation and support a role for Sprouty2 as a potential novel target for pharmacological inhibition

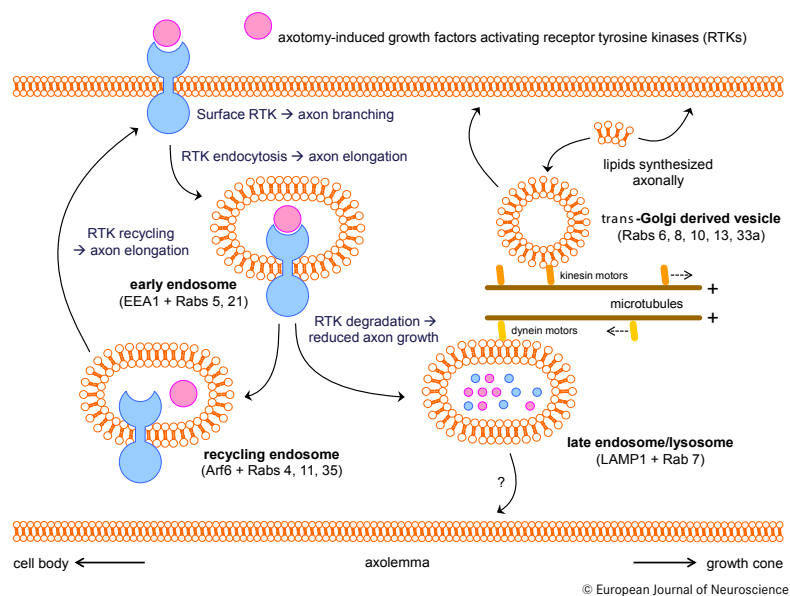

Fig. 1: Membrane supply and RTK shuttling in growing axons. Lipids travel through regenerating axons in the form of trans-Golgi derived or locally synthesised endosomal membranes. Kinesin-dependent vesicle transport along microtubules followed by regulated vesicle exocytosis, endocytosis and recycling results in membrane addition to axons and to growth cones. EEA1 (Early Endosome Antigen 1), LAMP1 (Lysosomal associated membrane protein 1), Arf6 (ADP-ribosylation factor 6) and other small GTPases of the Rab family (RAS related in brain) identify the different vesicle populations. Rab5 labels early endosomes which carry plasma membrane receptors following their activation and internalisation. Whereas surface receptor tyrosine kinases mainly induce axonal branching, internalised receptors signal from endosomes and preferentially stimulate axon elongation which is further increased by receptor recycling. Interference with lysosomal receptor degradation stimulates axonal growth in general. It is unclear whether lysosomal vesicles participate in membrane addition during their retrograde transport along the axon. Taken from EUROPEAN JOURNAL OF NEUROSCIENCE, 2016, 43, 309-317.

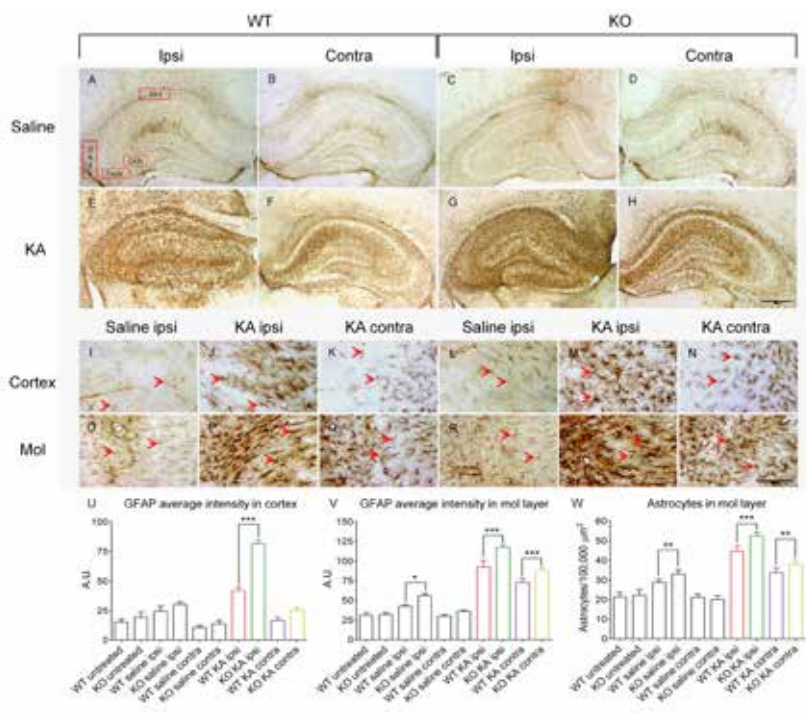

Fig. 2: Glial fibrillary acidic protein (GFAP) staining 3 weeks after unilateral injection of saline or KA (kainic acid) into the dorsal hippocampus. As compared to saline injection (A-D), prominent KA induced reactive astrocytosis is detected in the ipsilateral and contralateral hippocampus of both genotypes (E-H). *Spry2/4+/-* mice reveal higher GFAP intensity in the ipsilateral and contralateral molecular layers as compared with WT (wild-type) mice. Higher magnification of the cortex (I-N) and the molecular layer (Mol, O-T) are shown to reveal single astrocytes and their processes (arrowheads). Quantifications of GFAP average staining intensity in the cortex (U) and of the molecular layer (V) correlate with increased numbers of reactive astrocytes (W). Mean \pm SEM (n = 4), one-way ANOVA, bar = 500 μ m (A-H) or 100 μ m (I-T). Taken from *HIPPOCAMPUS*, 2016, 26, 658–667.

to accelerate long-distance regeneration in lesioned peripheral nerves. Members of our group also elucidated neuroprotective effects of combined *Sprouty2/4* reduction in a mouse model of human epilepsy-induced neurodegeneration (cooperation with Neuropharmacology) suggesting that enhanced ERK signalling by interference with *Sprouty* proteins may prevent neuronal degeneration in several brain disorders, possibly by stimulating astroglial proliferation (Fig. 2). Besides inhibiting the RAS/RAF/ERK pathway, *Sprouty2* appears to interfere with other signalling pathways (PI3K/AKT, PLC γ) and with FGFR1 trafficking. Benefiting from the expertise of the Geley lab (PhD program Molecular Cell Biology and Oncology), our PhD student Park developed tools to modulate *Sprouty2* levels by generating *Spry2W253* and *Spry2Y55* mutations via site directed mutagenesis. Moreover, we analyze cell proliferation, FGF dependent signalling and receptor trafficking in primary cells and in various neuronal and glioma cell lines applying FACS analysis, live-cell high-resolution receptor imaging and fluorescent reporters of signalling path-

ways. The tools developed will be used for several *in vivo* projects investigating the therapeutic potential of *Sprouty2* regulation in neurons or astrocytes following experimental brain injuries as well as in animal models of human glioblastoma. Finally, the possible significance of *Sprouty2*

methylation is currently investigated by group member Dr Valovka (Fig 3). Protein methylation involves an addition of methyl groups by S-adenosyl-methionine (SAM) dependent methyltransferases and is known to have a major effect on the functions of a protein. We are particularly interested in the protein arginine methyltransferase 1.

Selected Publications

Enhanced axon outgrowth and improved long-distance axon regeneration in *Sprouty2* deficient mice
 Marvaldi L, Thongrong S, Kozłowska A, Irschick R, Frei A, Pritz CO, Bäumer B, Ronchi G, Geuna S, Hausott B, Klimaschewski L. *DEVELOPMENTAL NEUROSCIENCE*, 2015, 75, 217-231

Schwann cell expressed Nogo-B modulates axonal branching of adult sensory neurons through the Nogo-B receptor NgBR
 Eckhartner C, Junker N, Winter L, Fischer I, Fogli B, Kistner S, Pfaller K, Zheng B, Wiche G, Klimaschewski L, Schweigreiter R. *FRONTIERS IN CELLULAR NEUROSCIENCE*, 2015, 9, 454

***Sprouty2* and *-4* hypomorphism promotes neuronal survival and astrocytosis in a mouse model of kainic acid induced neuronal damage**
 Thongrong S, Hausott B, Marvaldi L, Agostinho AS, Zangrandi L, Burtscher J, Fogli B, Schwarzer C, Klimaschewski L. *HIPPOCAMPUS*, 2016, 26, 658–667

siRNA mediated down-regulation of *Sprouty2/4* diminishes ischemic brain injury
 Klimaschewski L, Pinar Sueiro B, Martinez Millan L. *NEUROSCIENCE LETTERS*, 2016, 612, 48-51

Membrane turnover and receptor trafficking in regenerating axons (Review)
 Hausott B, Klimaschewski L. *EUROPEAN JOURNAL OF NEUROSCIENCE*, 2016, 43, 309-317

Selected Funding

- Morphological consequences of fibroblast growth factor (FGF) dependent signaling mechanisms (2 students within PhD program „Signal Processing in Neurons“), FWF (W1206-B05), Dr L. Klimaschewski
- Receptor tyrosine kinase trafficking in neurons and glioma cells in response to *Sprouty2* regulation, FWF (P 28909-BBL), Dr B. Hausott
- Regulation of PRMT1 by multiple phosphorylations/Regulation der PRMT1 durch Proteinphosphorylierung, FWF (P24251-B20), Dr T. Valovka

Collaborations

- Ludwig Boltzmann Institute for Traumatology, Vienna
- University of the Basque Country, Spain, Department of Neurosciences
- Universitat Autònoma de Barcelona, Spain, Department of Physiology
- University of Torino, Italy, Department of Clinical and Biological Sciences
- The Norwegian Radium Hospital, Norway, Department of Biochemistry, Institute for Cancer Research
- Hannover Medical School, Germany, Center for Anatomy
- University Cologne, Germany, Institute for Anatomy
- University Berlin (Charité), Germany, Center for Anatomy
- Yeditepe University Istanbul, Turkey, Department of Genetics and Bioengineering
- University of Zagreb School of Medicine, Croatia, Laboratory for Regenerative Neuroscience

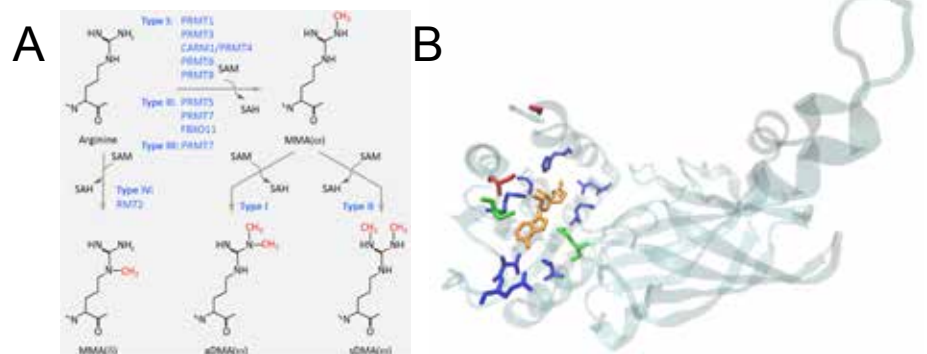

Fig.3: A) Chemistry of arginine methylation. Methylation of arginines in proteins is catalysed by the family of protein arginine methyltransferases PRMTs (indicated in blue). B) 3D structure of the major type I protein arginine methyltransferase 1 explaining the molecular details of SAM binding. Amino acid residues mediating recruitment of SAH (S-adenosyl-L-homocysteine) (orange) into the cofactor binding pocket are shown in red, green and blue.

Histology and Embryology



Head of Division (interim):
Univ.-Prof. Dr. Lars Klimaschewski

Contact:

Müllerstraße 59
6020 Innsbruck

Lars.Klimaschewski@i-med.ac.at
Phone: +43 512 9003 71160
Fax: +43 512 9003 73112
www.i-med.ac.at/ahe/
histologie-embryologie

Research Branch (ÖSTAT Classification)

106049, 106052, 301107,
301114, 301304

Keywords

Cellular electron microscopy, organelle ultrastructure, membrane trafficking, endosomal/lysosomal pathways, autophagy, targeted nanoparticles, colon cancer, molecular imaging, early diagnosis

Research Focus

High-resolution microscopy with emphasis on ultrastructural analyses of subcellular architecture in the context of intact tissues and cells from model organisms and patient samples. Both groups in the Unit focus on imaging, the group of Prof. Hess on high-resolution microscopy and the group of Prof. Debbage on molecular imaging using fluorescent nanoparticles.

General Facts

The Division of Histology and Embryology at the Medical University of Innsbruck provides lecture series and practical courses in Histology for undergraduate students in Human Medicine and Molecular Medicine. In addition, we offer special lectures and courses on submicroscopic morphology, and on advanced cellular electron microscopy for MD and PhD students. The Cellular Electron Microscopy group

focuses research on ultrastructural aspects of intracellular membrane trafficking and signaling, performed in close collaboration with local and international research groups. The Endothelial Biology Group focuses on early diagnostics of colorectal cancer by use of fluorescent targeted nanoparticles.

Research

Cellular Electron Microscopy

Michael W. Hess

High-resolution microscopy with emphasis on ultrastructural analyses of subcellular architecture in the context of intact tissues and cells from model organisms and patient samples. Our cell biological research concentrates on ultrastructural aspects of intracellular membrane trafficking and signalling (e.g., Refs. (Vogel GF, *et al.* 2015)) in various organisms, performed in collaboration with the groups of L.A. Huber and D. Teis (Division of Cell Biology), as well as T. Müller, A. Janecke, G.F. Vogel (Department of Paediatrics I). Our methods of choice for investigating (genome-edited) human and animal cell models, biopsy samples from patients and eukaryotic model organisms such as mice, yeast, flatworms and the freshwater polyp Hydra are advanced cryo-based immuno-electron microscopy and electron tomographic 3D-reconstruction. Membrane trafficking is studied with special emphasis on the biogenesis and maturation of endocytic compartments (Vogel GF, *et al.* 2015), cargo biosynthesis and recycling, as well as autophagy. Among others we are also interested in the relationships between cargo biosynthesis and trafficking, cytoskeletal architecture and maintenance of cellular polarity. All these processes are severely disturbed in Microvillus Inclusion Disease (MVID), a rare, fatal congenital intestinal disease that affects infants soon after birth; the clinical appearance presents severe watery, non-inflammatory diarrhoea, nutrient malabsorption and metabolic acidosis. In general, MVID patients depend on total parenteral nutrition. Small bowel transplantation is the only curative therapy, but many patients die within the first few years of life (Vogel GF, *et al.* 2016). In the previous years our multidisciplinary cell biological-clinical team provided mechanistic insight into the pathophysiology of MVID (Vogel GF, *et al.* 2015). We demonstrated mutations in the motor protein Myosin5b or the apical membrane protein Syntaxin3, disrupting selective apical cargo trafficking and exocytosis in epithelial absorptive cells of the small intestine, leading to mislocalisation of pivotal brush border ion transporters rel-



Fig. 1: Immuno-electron microscopic detection of fluorescently-tagged FGFR1 (fibroblast growth factor receptor1) transiently expressed in U373 human glioblastoma cells. Immuno-gold-particles (arrows) localize to endo/lysosomal compartments and the plasma membrane (unpublished data by M.W. Hess in collaboration with L. Klimaschewski and K. Czanaky (Division of Neuroanatomy)).

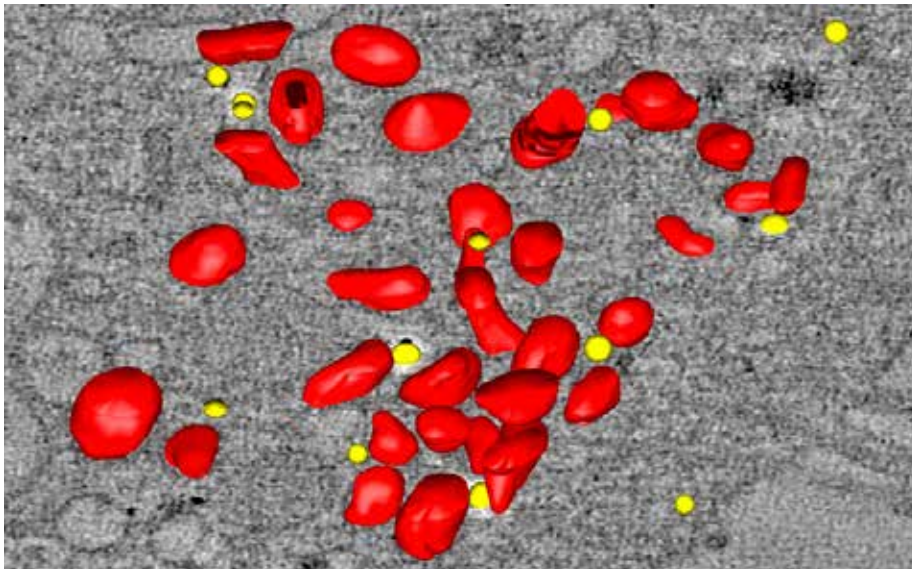

Fig. 2: 3D-modelling of the immuno-electron microscopic localization patterns of fluorescently-tagged Rab11 stably expressed in human CaCo2 colon carcinoma cells. Immunogold-particles (yellow) localize preferentially to vesiculo-tubular recycling endosomes (red) in the subapical cytoplasm (unpublished data by M.W. Hess and G.F. Vogel (formerly: Division of Histology and Embryology)).

evant for physiological enterocyte function. These data, obtained from our genome-edited cell models, have recently been further complemented by thorough analyses of an inducible Myosin5b knock-out mouse model (Schneeberger K., *et al.* 2015), generated by our long-term collaborators from UMC-Utrecht (S. Middendorp, H. Clevers). Another major focus of our electron microscopy group is methodological research for the development of new preparation and imaging techniques for precise 3-dimensional localisation of macromolecules in the context of natively cryo-immobilised tissues and cells, as shown, for example in Fig. 1 and 2.

Endothelial Biology Group

Paul Debbage, Gudrun Thurner

Pivoting towards epithelial biology, Prof. Paul Debbage and Dr. Gudrun Thurner develop nanoparticles for molecular imaging to achieve early diagnose of cancerous lesions in the human body. Our main focus at the moment is on colorectal carcinoma cancer lesions, but other tumorous lesions are in our broader field of research, including therapy of such lesions.

We coordinate the European EraNet research project NanoEFFECT (2014 to 2017) (<https://www.cesar.or.at/main.asp?kat1=96&kat2=699&kat3=540>; www.i-med.ac.at/mypoint/thema/697136.html), an international consortium consisting of five partners, three scientific partners concerned with the development of different

kinds of nanoparticles: SINTEF (Foundation for industrial and technical research) in Norway; led by Dr. Ruth Schmid developing PACA nanoparticles, the University of Porto in Portugal led by Prof. Manuel Coelho developing gold nanoparticles and the Medical University of Innsbruck, led by Prof. Paul Debbage (coordinator) developing protein nanoparticles. The consortium includes one clinical partner: the Gastroenterology Clinic at the Friedrich-Alexander University Erlangen-Nürnberg, led by Prof. Maximilian Waldner, and one management partner: CESAR in Vienna (Central European Society for Anticancer Research) not only providing management but also interfacing with regulatory authorities, led by Dr. Berta Moritz and Dr. Max Rössler. The NanoEFFECT consortium created a series of candidate nanomaterials for use in diagnosis of colorectal carcinoma; Figure 1 shows the type of imaging achieved by our Innsbruck team. During 2016 this work of our group won the CAST technology award (<https://www.i-med.ac.at/mypoint/news/704443.html>) and was evaluated positively in a competitive evaluation by the European Nanomedicine Translation Advisory Board (<http://www.enatrans.eu/public/services/translation-advisory-board/translation-advisory-board>, Nanomed TAB).

In successor projects we plan to optimise our successful strategy and move forward to translational activities in collaboration with the Tyrol Clinics. by S-adenosyl-methionine

(SAM) dependent methyltransferases and is known to have a major effect on the functions of a protein. We are particularly interested in the protein arginine methyltransferase 1.

Selected Publications

Hess Group:

Ultrastructural Morphometry Points to a New Role for LAMTOR2 in Regulating the Endo/Lysosomal System

Vogel, Georg F., Ebner, Hannes L., de Araujo, Mariana E., Schmie-dinger, Thomas, Eiter, Oliver, Pircher, Haymo, Gutleben, Karin, Witting, Barbara, Teis, David, Huber, Lukas A., Hess, Michael W, TRAFFIC: 2015; 16: S. 617-634

Cargo-selective apical exocytosis in epithelial cells is conducted by Myo5B, Slp4a, Vamp7, and Syntaxin 3

Vogel, Georg F., Klee, Katharina M., Janecke, Andreas R., Muller, Thomas, Hess, Michael W., Huber, Lukas A., JOURNAL OF CELL BIOLOGY: 2015; 211: S. 587-604.

Towards understanding microvillus inclusion disease

Vogel, Georg F., Hess, Michael W., Pfaller, Kristian, Huber, Lukas A., Janecke, Andreas R., Muller, Thomas, MOLECULAR AND CELLULAR PEDIATRICS: 2016; 1: S.3

An inducible mouse model for microvillus inclusion disease reveals a role for myosin Vb in apical and basolateral trafficking

Schneeberger, Kerstin, Vogel Georg F., Teunissen Hans, van Ommen Dominique D., Begthel, Harry, El Bouazzaoui, Layla, van Vugt, Anke H.M., Beekman, Jeffrey M., Klumperman, Judith, Muller, Thomas, Janecke, Andreas, Gerner, Patrick, Huber, Lukas A., Hess, Michael W., Clevers, Hans, van Es, Johan H., Nieuwenhuis, Edward, e.S., Middendorp, Sabine, PROCEEDING OF THE NATIONAL ACADEMY OF SCIENCES OF THE UNITED STATES OF AMERICA: 2015; 40:S. 12408-12413.

Debbage Group:

Targeted drugs and nanomedicine: present and future.

Thurner GC, Chabicosky M, Abdelmoez A, Debbage P (2015) FRONTIERS IN MEDICINAL CHEMISTRY, 2015;9: S 182 - 233;

Colorectal diagnostics: the NanoEFFECT project.

Debbage P, Schmid R, Coelho MAN, Waldner M, Moritz B HÄMATOLOGIE & ONKOLOGIE:2015; 5: S.122 - 124

Screening and identification of molecular targets for cancer therapy

Abdelmoez A, Coraça-Huber DC, Thurner GC, Debbage P, Lukas P, Skvortsov S, Skvortsova I (2016) CANCER LETTERS; doi: 10.1016/j.canlet.2016.03.002

Collaborations

- Sabine Middendorp (Department of Paediatric Gastroenterology, Wilhelmina Children's Hospital, University Medical Centre (UMC) Utrecht, 3584 EA, Utrecht, The Netherlands)
- Ernest Cutz (Division of Pathology, Department of Paediatric Laboratory Medicine, The Hospital for Sick Children, Toronto, Ontario, Canada)
- James R. Goldenring (Section of Surgical Sciences, Epithelial Biology Center, and Department of Cell & Developmental Biology, Vanderbilt University School of Medicine, Nashville, TN, USA)
- Dr. Maria Vicent (CIPE, Valencia, Spain);
- Prof. Axel Walch (Helmholtz Institute, Munich, Germany);
- Contipro a.s., an industrial firm in Dolní Dobrouč, Czech Republic.
- The ETP (European Technology Platforms) and particularly Prof. Patrick Boisseau and Prof. Mike Eaton.
- Clinic for Gastro-Enterology (Prof. Herbert Tilg; Prof. Hubert Schwaighofer)
- Clinic for Radiology (Prof. Werner Jaschke)
- Clinic for Radiotherapy and Radiooncology (Prof. Peter Lukas)
- Clinic for Obstetrics and Gynaecology (Dr. Elisabeth Sölder)
- Clinical Biochemistry, Biozentrum (Prof. Heribert Talasz)
- Department of Pharmaceutical Chemistry (Prof. Barbara Matyszczak)
- Department of Pharmaceutical Technology (Prof. Andreas Bernkop-Schnürch)

Hygiene and Medical Microbiology



Head of Division:
Univ.-Prof.ⁱⁿ Dr.ⁱⁿ Cornelia Lass-Flörl

Contact:
Schöpfstraße 41
6020 Innsbruck

Hygiene-Bakteriologie@i-med.ac.at
Phone: +43 512 9003 70703
Fax: +43 512 9003 73700
www.i-med.ac.at/hygiene

Branch of Research (Östat Classification)

303026, 303002, 303015,
303013, 303020

Keywords

Infectious diseases, hygiene, immunity, fungal pathogens, antifungal resistance, EHEC, HIV, dendritic cells, platelets, complement, N-chlorotaurine, nosocomial infections, public health

Research Focus

Understanding Infections: From Pathogenesis to Diagnosis

- The tasks of the Division of Hygiene and Medical Microbiology (HMM) comprise research, teaching, laboratory diagnosis of infectious diseases, environmental, hospital and technical hygiene as well as public health.
- Scientific activities cover fungal pathogenicity, antifungal resistance, virulence factors, molecular mechanisms of host pathogen-interaction including the complement system, basic immunological research (interactions of dendritic cells/T-cells), antimicrobial agents (antimycotics and endogenous antiseptics), enterohem-

orrhagic E. coli and prevention of nosocomial infections.

- HMM seeks to prevent illness and death from targeted infectious disease threats through research and the translation of scientific information into real-world, practical applications, policies, and solutions (Figure 1).

General Facts

Infectious diseases are turning into one of the most frequent causes of death in the world; presently we face bacteria and fungi to develop resistances to antibiotics and antimycotics and the fact that an increasing number of emerging pathogens spread worldwide. Understanding of biological principles underlying the mechanisms by which infectious agents adapt, and undermine the defence mechanisms of a host is critical for fighting diseases. HMM conducts basic and translational research on molecular mechanisms of pathogenesis of bacterial, viral, or fungal infections and strategies for their prophylaxis and therapy. HMM's mission is to coordinate and strategically align translational infection research with the aim of developing new diagnostic, preventative and therapeutic methods for treating infectious diseases. To achieve this, HMM has formed

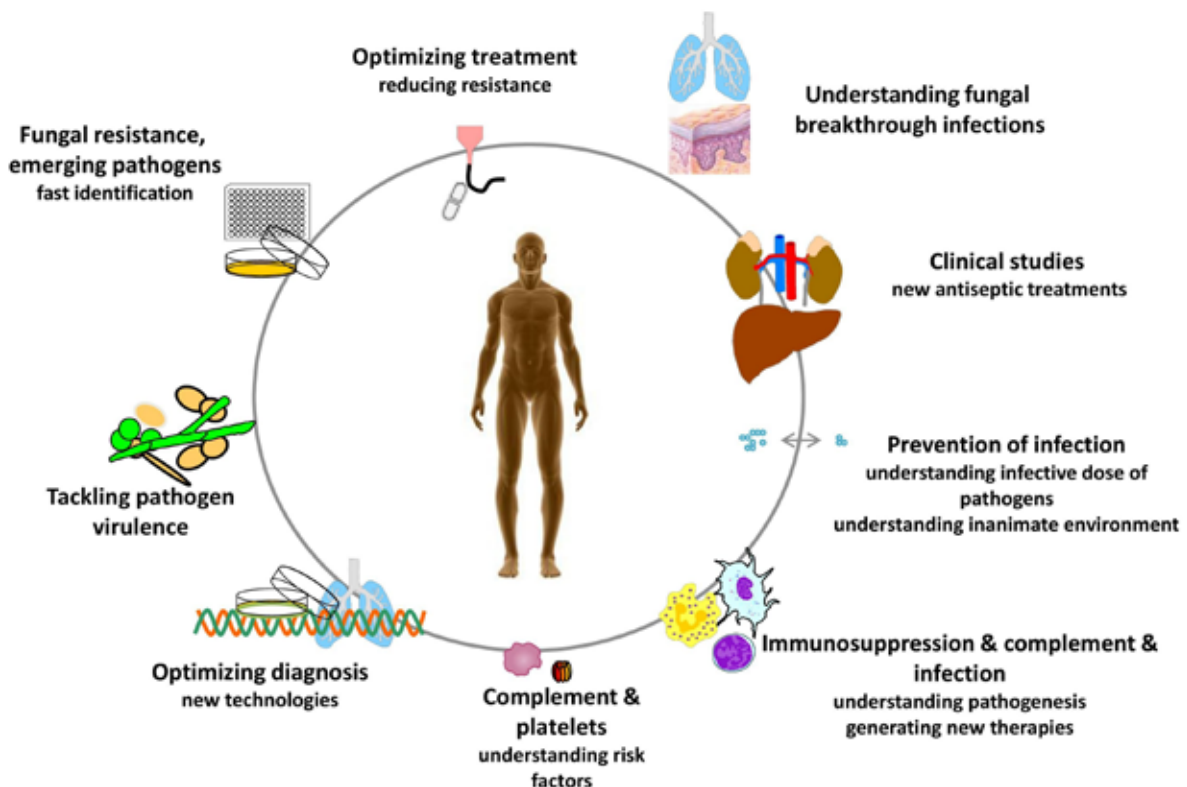

Fig. 1: Translation of in vitro to in vivo – overview of research questions targeted at HMM.

Research

Emerging Infections with a Focus on Enterohemorrhagic Escherichia Coli (EHEC)-Induced Hemolytic Uremic Syndrome (HUS)

Experiences of the last decade clearly demonstrate the vulnerability of modern society to emerging pathogens. Outbreaks and epidemics affect virtually all aspects of our lives, threatening health. A prompt health-care response is critical to prevent a rapid spread of infection and requires knowledge of the pathogen, pathogen reservoirs, and risk-factors as well as broad-spectrum drugs. Researchers (WG Orth-Höller & WG Würzner) investigate the interaction of EHEC virulence factors with the complement cascade and evaluate whether a transient complement blockade opens new therapeutic strategies. HMM will pursue immune modulation strategies focusing on the role of complement, and will provide genetic factors potentially responsible for disease development (Figure 3).

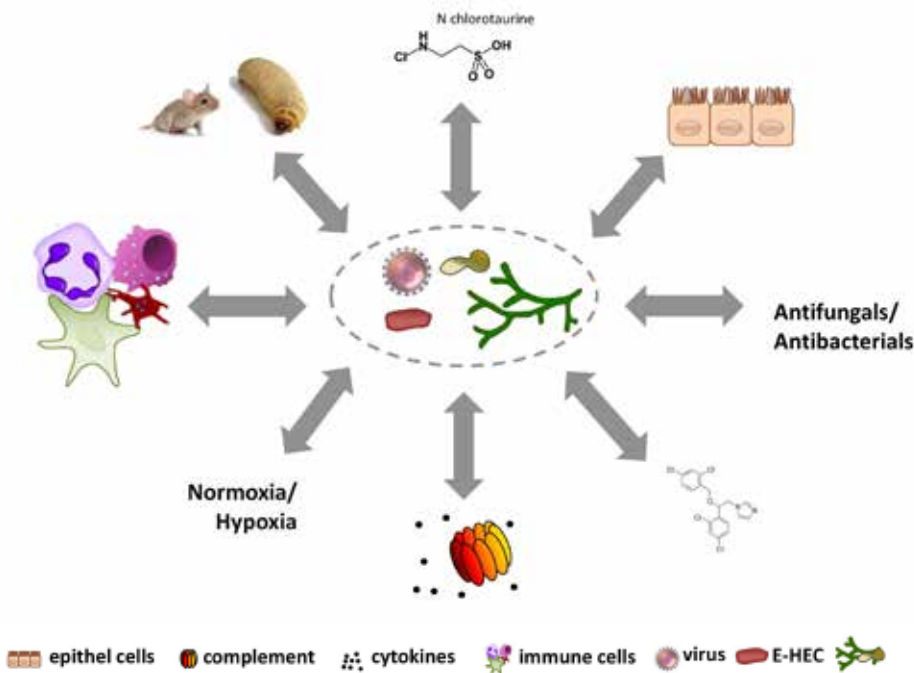

Fig. 2: Identifying underlying networks contributing to infectious diseases.

thematic translational units of scientists, each dedicated to one specific pathogen or infectious disease. HMM is one of the largest microbiology diagnostic laboratories in Austria, with an average sample throughput of 250,000 specimens per year. HMM is associated to with all major hospitals in Tyrol, placing it in a key position in the diagnostic laboratory landscape in Austria. The research part of the division consists of 7 Associate-Professors, 1 Assistant-Professor, 5 Post-Docs, several PhD-, Master and Bachelor students and 7 technical assistants. The diagnostic unit consists of 9 medical doctors, 3 Post-Docs, and 26 technical assistants.

The mission of HMM is to bridge the gap between basic and translational research into microbial pathogenesis (Figure 2).

Christian-Doppler-Laboratory for Invasive Fungal Infection

In 2015 a “Christian-Doppler (CD)-Laboratory for Invasive Fungal Infections” was set up. Within the estimated 2 million fungal species on earth, about 600 cause diseases in humans; the most important are *Candida*, *Aspergillus*, *Mucorales* and *Cryptococcus*. Fungal infections are increasing and are associated with excessive morbidity and mortality (Fig. 3). Over 300 million people are acutely or chronically infected, leading to death, long term illness, and reduced work capacity. The reasons this problem has emerged are likely multifactorial,

e.g. the advent of medical progress, the successful application of immunosuppression in transplanted patients, and the use of immunomodulatory agents for treating various diseases from cancer to rheumatoid arthritis.

Reducing the incidence relies on rapid and specific diagnosis, effective antifungal drugs, novel immunotherapeutic strategies, and adherence to infection control and sterility practices.

CD-Fungus deals with the following three main research questions: How to best find, treat and prevent mucormycosis?

- Tackling these key questions needs
1. recognising mucormycosis as such
 2. identification of the source and type of infection
 3. identification of the pathogen
 4. understanding the underlying pathomechanisms
 5. initiation of early targeted treatment, and
 6. providing a clean and safe hospital environment.

CD-Fungus attempts to unravel scientific questions raised by implementing 3 modules which will ultimately advance our understanding of fungal pathology, improve diagnosis and treatment of mucormycosis and enhance patients’ outcome and safety in terms of prevention of nosocomial and hospital-associated infections.

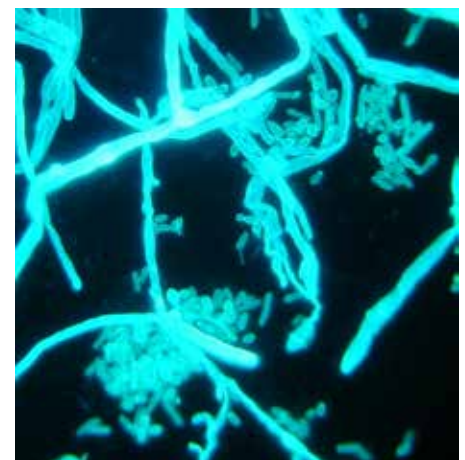

Fig. 3: Invasive fungal lung infection displaying hyphae (*mucor species*) and yeast cells.

Exploiting Immune Response to Infection

The human immune system is constantly active in combating diseases. Researchers have developed novel methods for assessing the immune response in molecular detail focusing on HIV-1 and opportunistic fungal pathogens. During the acute and chronic phases of infection, dendritic cells (DC), macrophages and platelets are of major interest. Various aspects of opsonization (complement, antibody) as well as the impact of cellular complement are considered in all *in vitro* experimental set-ups to mimic the *in vivo* situation. Furthermore 3D cell-cultures of lung and lymphoid tis-

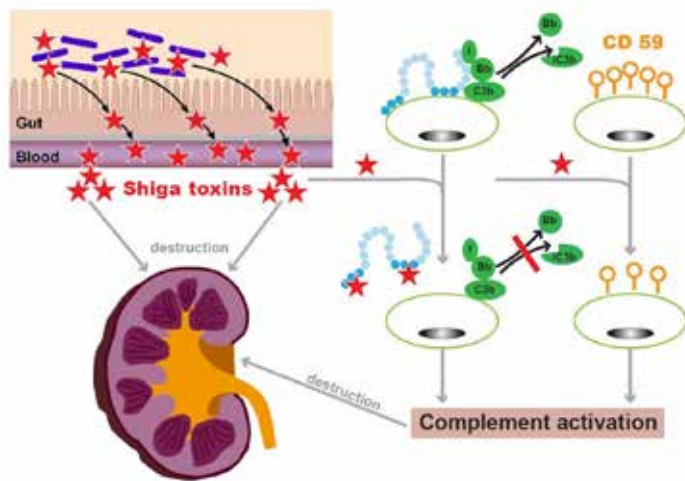

Fig. 4: Involvement of the complement system in the pathogenesis of EHEC-associated HUS

issues are developed in a perfusion system to study host-pathogen interactions in an immunological setting close to reality (WG Wilflingseder). These studies focus on the impact of viral opsonisation patterns on signalling pathways within DCs, on DC maturation, and on DC antigen presentation to CD4+ and CD8+ T cells (WG Wilflingseder & WG Posch; Figure 4).

Another goal is to evaluate the interaction of platelets and fungal pathogens; such interplay might result in mutual platelet activation or inhibition, hence resulting in additive antifungal defence or excessive inflammation and thrombosis (WG Speth-Rambach). Another project aims at elucidating fungal proteins which allow pathogens to escape from complement interactions, subsequently protecting the fungus from the destructive action of an activated immune system (WG Würzner). This groundbreaking research is forming the basis for the development of novel treatment strategies and eventually of vaccines.

Fungal Infections of the Immunocompromised Patient

Our aging population and the growing prevalence of chronic diseases force modern medicine to use aggressive cancer therapies and organ or bone marrow transplantation, which result in or require immunosuppression. In immunocompromised patients, fungal pathogens, usually efficiently controlled by the immune system, can cause life-threatening diseases that may be difficult to treat with currently available anti-mycotics. While the degree of immune alteration is a major contributor to fungal disease in immunocompromised patients, knowledge of other factors related to treatment failure is limited. Hence, various new

in vitro and *in vivo* models are under investigation (WG Binder-Lass-Flörl, WG Wilflingseder, WG Speth). HMM will pursue immune modulation and new treatment strategies to provide promising options for the development of novel and more effective antifungal therapies. This topic is also dealt with in the FWF-funded doctoral programme of excellence, HOROS, for **HOst Response in Opportunistic infections** and the Christian Doppler laboratory for invasive fungal infections.

Therapy-Resistant Fungal Infections

A disturbing and rapid increase of infections caused by antimycotic-resistant fungal pathogens is a big public health concern which medicine is facing today. Most severe and fatal cases result from healthcare-associated fungal infections, which are increasingly caused by *Candida*, *Aspergillus* and *Mucorales*. Hence, a major focus is to investigate azole and echinocandin-resistance in yeasts and molds and to discover

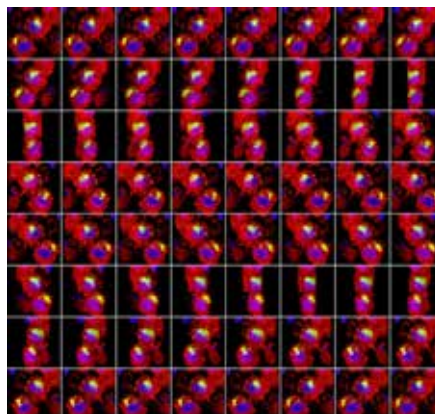

Fig. 5: Three-dimensional image of dendritic cells infected with HIV-1

new resistance mechanisms (WG Lackner-Lass-Flörl). Another main focus is to identify the underlying mode of amphotericin B resistance in *Aspergillus terreus*. In this context we evaluate mitochondria as crucial modulators of polyene resistance (WG Wilflingseder-Blatzer-Lass-Flörl). The mission of HMM is to bridge the translational gap between basic research and the development of novel antifungal drugs. HMM will support epidemiologic, translational and clinical studies to improve the management of fungal diseases.

N-Chlorotaurine: Assessing of New Antiseptic Solutions and Antimicrobial Surfaces

N-chlorotaurine, a long-lived oxidant produced by activated human leucocytes, has been synthesized as sodium salt in our division and is under clinical investigation for local treatment of infections of multiple body regions, including sensitive ones (Figure 5). Inhalation is one of the most promising recent topics. Basic research assesses its microbicidal activity against biofilms and investigates the activity against emerging pathogens (WG Nagl). While antibiotics are frequently considered the first line of containment for nosocomial infections, there is increasing effort being devoted to prevent infections. Researchers at the division are screening surface materials that prevent bacteria, viral and fungal contamination and persistence on medical surfaces (WG Mayr-Lass-Flörl).

Laboratory Diagnostics, Hospital and Technical Hygiene

The division HMM fulfils its tasks in detection and identification of pathogens causing infections. This covers bacteriology, parasitology, mycobacteriology and mycology. The diagnostic laboratories are certified according to ISO 9001:2009. Special parts are controlled by external audits in accordance to §67 Austrian Medicines Law and FDA, Division of Manufacturing and Product Quality. Within the sector of hospital and technical hygiene (accredited according to ISO/IEC 17025 and ISO/IEC 17020) guidelines for prevention of infectious diseases are developed and controlled corresponding to the statutory prescription for technical facilities (e.g. disinfection machines).

Public Health

Vaccine hesitancy is a growing complex and context specific problem in many European countries and the elimination goal of rubella and measles is at stake. Understanding the magnitude of the problem and identifying

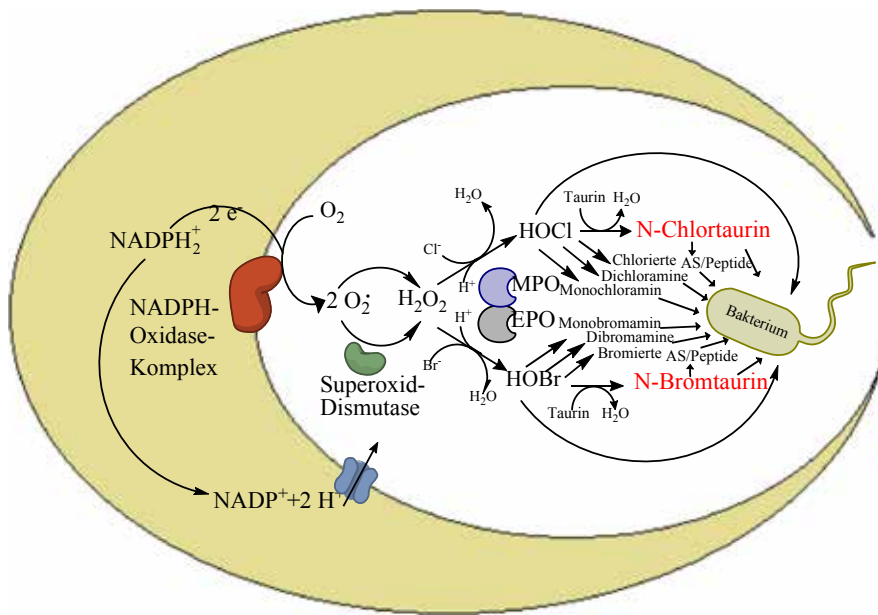

hmm
sektion für hygiene und
medizinische mikrobiologie



Christian Doppler
Forschungsgesellschaft

Fig. 6: Synthesis of N-chlorotaurine by human granulocytes.

the root causes of the determinants of hesitancy are essential to tailor immunization strategies. Researchers investigate determinants of vaccine hesitancy and effectiveness of tailored communication strategies to address concerns and finally increase vaccine uptake.

Selected Publications

Geographically predominant genotypes of *Aspergillus terreus* species complex in Austria: a microsatellite typing study

Lackner M, Coassin S, Haun M, Binder U, Kronenberg F, Haas H, Jank M, Maurer E, Meis JF, Hagen F, Lass-Flörl C. CLIN MICROBIOL INFECT: 2016;22:270-276.

N-Chlorotaurine exhibits fungicidal activity against therapy-refractory *Scedosporium* species and *Lomentospora prolificans*

Lackner M, Binder U, Reindl M, Gönül B, Fankhauser H, Mair C, Nagl M. ANTIMICROB AGENTS CHEMOTHER: 2015;59:6454-6462.

Identification of *Aspergillus fumigatus* surface components that mediate interaction of conidia and hyphae with human platelets

Rambach G, Blum G, Latgé JP, Fontaine T, Heinekamp T, Hagleitner M, Jeckström H, Weigel G, Würtinger P, Pfaller K, Krappmann S, Löffler J, Lass-Flörl C, Speth C. J INFECT DIS: 2015;212:1140-1149.

Microbial contamination of glaucoma eyedrops used by patients compared with ocular medications used in the hospital

Teuchner B, Wagner J, Bechrakis NE, Orth-Höller D, Nagl M. MEDICINE (Baltimore): 2015; 94:e583.

Prospective multicenter PCR-based *Aspergillus* DNA screening in high-risk patients with and without primary antifungal mould prophylaxis

Springer J, Lackner M, Nachbaur D, Girschikofsky M, Risslegger B, Mutschlechner W, Fritz J, Heinz WJ, Einsele H, Ullmann AJ, Löffler J, Lass-Flörl C. CLIN MICROBIOL INFECT: 2016;22:80-86.

Complement-opsonized HIV-1 overcomes restriction in dendritic cells

Posch W, Steger M, Knackmuss U, Blatzer M, Baldauf HM, Doppler W, White TE, Hörtnagl P, Diaz-Griffero F, Lass-Flörl C, Hackl H, Moris A, Keppler OT, Wifflingseder D. PLoS PATHOG: 2015;11:e1005005.

Selected Funding

FWF W1253-B24: HOROS Doctoral Programme of Excellence "Wirtsabwehr bei opportunistischen Infektionen". 2014 - 2018

FWF KL1459: Tolerability of inhaled N-chlorotaurine in humans - a phase I clinical study. 2015 - 2016

FWF P24598-B13: HIV infection and transmission close to reality. 2012 - 2016 FWF W011010-21: Deciphering complement- and Fc-receptor-mediated HIV-1 incorporation in and effects on DC function in search for novel therapeutical targets. 2015 - 2019 FWF P25389-B13: Deciphering the role of Th17 paradigm for viral infections. 2013 - 2016 FWF P26117-B20: Relevance of platelets and complement for the pathogenesis of invasive fungal infections 2014 - 2016

CD-Labor für Invasive Pilzinfektionen. 2015 - 2022

FP7-PEOPLE-2013-ITN: ITN (Marie Skłodowska-Curie actions). From omics to patient improving diagnostics of pathogenic yeasts. 2015 - 2019 FWF KL1005610: NOBICS - Novel Biomarker in Invasive Candidiasis/Candida.2016-2019

Collaborations

- Jacques Meis and colleagues, Canisius Wilhelmina Hospital and Radboud University Medical Centre, Nijmegen, The Netherlands
- Sybren de Hoog, Fungal Biodiversity Centre, Utrecht, The Netherlands
- Maiken C. Arendrup, Staten Serum Institut, Copenhagen, Denmark
- Axel Brackhage and colleagues, Hans Knöll Institut, Jena, Germany
- Ricardo Araujo and colleagues, Institute of Molecular Pathology and Immunology of the University of Porto, Portugal
- Kevin Kavanagh, National University Ireland, Maynooth, Ireland
- Mike Birch, f2G Manchester, UK
- Helge Karch and colleagues, University Münster, Münster, Germany
- Simon Satchell, University of Bristol, Bristol, United Kingdom
- Asier Saez-Cirion, Unité de Régulation des Infections Rétrovirales, Institut Pasteur, France
- Arnaud Moris, INSERM UMR5945, Infection et Immunité, UPMC, France
- Teunis Geijtenbeek, Center of Infection and Immunity, Academic Medical Center, Netherlands
- Felipe Diaz-Griffero, Department of Microbiology and Immunology, Albert Einstein College of Medicine, NY 10461, US
- Frank Ebel, Max-von-Pettenkofer-Institut, München, Deutschland
- Admar Verschoor, TU München, München, Deutschland
- Jean-Paul Latgé, Institut Pasteur, Paris, Frankreich
- Sven Krappmann, Universitätsklinikum Essen, Deutschland
- Jürgen Löffler, Universitätsklinikum Würzburg, Deutschland
- Donald C. Sheppard, McGill University Montreal, Canada

Virology



Head of Division:
Univ.-Prof.ⁱⁿ Dr.ⁱⁿ
Dorothee Holm-von Laer

Contact:
Peter Mayr Straße 4b
6020 Innsbruck

Dorothee.von-Laer@i-med.ac.at
Phone: +43 512 9003 71701
Fax: +43 512 9003 73701
http://www3.i-med.ac.at/virologie

Research Branch (ÖSTAT Classifications)

303034, 301906, 301902, 302091

Keywords

Virology, virologic diagnostics, innate immunity, virotherapy, cancer immunotherapy, vaccines

Research Focus

The focus of the division of Virology is to develop novel biopharmaceuticals and vaccines. This research spans from elucidating the modes of action of novel therapeutics to the clinical translation and development in the spin-off biotech companies of the division. Specific foci are:

- Virus-based oncolytic cancer vaccine strategies and their mode of action.
- Viral vector-based vaccines primarily against HIV.
- Complement-enhanced vaccines and therapeutic antibodies.

General Facts

Structure: The Division of Virology has two professors: Dorothee von Laer, the director,

and Heribert Stoiber, the deputy director. In addition, there are three junior group leaders: Dr. Guido Wollmann, oncolytic viruses, and Dr. Janine Kimpel, vector vaccines, associated with D.v.Laer, as well as Dr. Zoltan Banki, complement and dendritic cell vaccines, associated with H. Stoiber.

Clinical routine: Around 30% of the employees work in the serologic and virologic diagnostics group, which services the university hospital Innsbruck (LKI), the regional hospitals and medical practices.

Collaborations: The division has developed an oncolytic viral cancer vaccine as well as complement enhanced therapeutic antibodies. To drive these two developments into clinical application, two companies were founded, ViraTherapeutics GmbH (founder D.v.Laer) and Lysovac (founder H. Stoiber), respectively. ViraTherapeutics has recently secured an investment from Boehringer Ingelheim that will cover the development up to early clinical phase II trials.

The division collaborates with several international groups and in addition with groups and clinics in Innsbruck: Haematology and Oncology (Gastl), Urology (Culig, Horninger), Gynaecology (Fiegl, Mart), Dermatology (Romani) a.o.

Core facility: The division established and is now coordinating (Dr. Janine Kimpel) the BSL2 and BSL3 animal facility of the Medical University Innsbruck, including an *in vivo* imaging system (IVIS- PerkinElmer).

Research

Complement, Dendritic Cells and T Cell Responses in Retroviral Infections

Zoltan Banki and Heribert Stoiber

As professional antigen presenting cells, dendritic cells (DC) have a key function in the initiation of specific T-cell responses upon infections with viruses including retroviruses. Complement opsonization of

retroviruses enhances the infection of DCs and influences DC-mediated induction of virus-specific CD8 T cell (Fig. 1) as well as regulatory T cell (Treg) responses. In friend virus (murine retrovirus) infection of mice, Treg mediate the shift of a primarily CD8 driven virus control to a cytotoxic CD4 cell response. Similarly, Tregs play a pathogenic role in other chronic infections with viruses including HIV and HCV. Interestingly, we found that the FV-driven Treg induction and expansion is complement dependent. In an FWF-funded project, we now aim to elucidate the mechanisms involved.

Combined Dendritic Cell Vaccine with Oncolytic VSV-GP Virotherapy

Dorothee von Laer, Zoltan Banki

Oncolytic viruses (OV) represent a promising cancer therapy option by specifically replicating in and killing cancer cells while leaving healthy cells undamaged. The oncolytic virus, VSV-GP, has been successfully tested in several xenograft and syngeneic mouse tumour models. Since oncolytic activity of VSV-GP releases antigens from cancer cells they induce an anti-cancer immune response which was found to be enhanced by a DC-based cancer vaccine (Koske et al, in prep). Studies of the mechanism are revealing a complex interplay of the antiviral and antitumoral immune response.

VSV-GP-Based Viral Vector Vaccines

Dr. Janine Kimpel

Live-attenuated vaccines have proven to be highly protective and cost-effective. For diseases, for which safe live-attenuated vaccines cannot be generated, e.g. HIV, Malaria, HCV and cancer, viral vector vaccines are a promising alternative. We have previously described the first viral vector vaccine, VSV-GP, that does not induce neutralizing antibodies to the viral vector in mouse models (Tober et al., 2014). VSV-GP is the vesicular

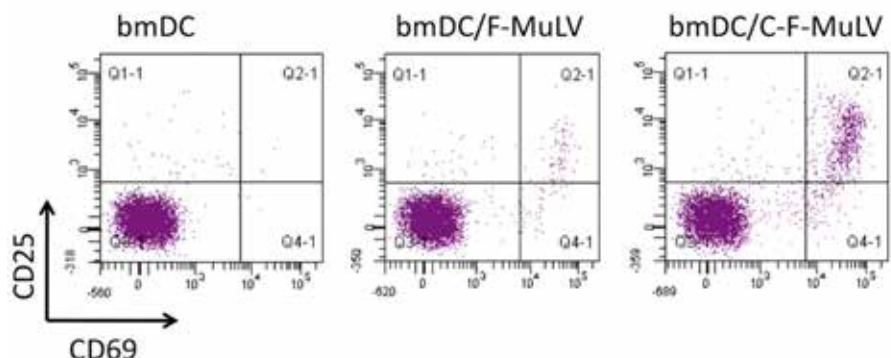

Fig. 1: Dendritic cells (DCs) treated with complement-opsonized retrovirus Friend murine leukemia virus (C-F-MuLV) are more effective in stimulating T cells than DCs treated with F-MuLV alone.

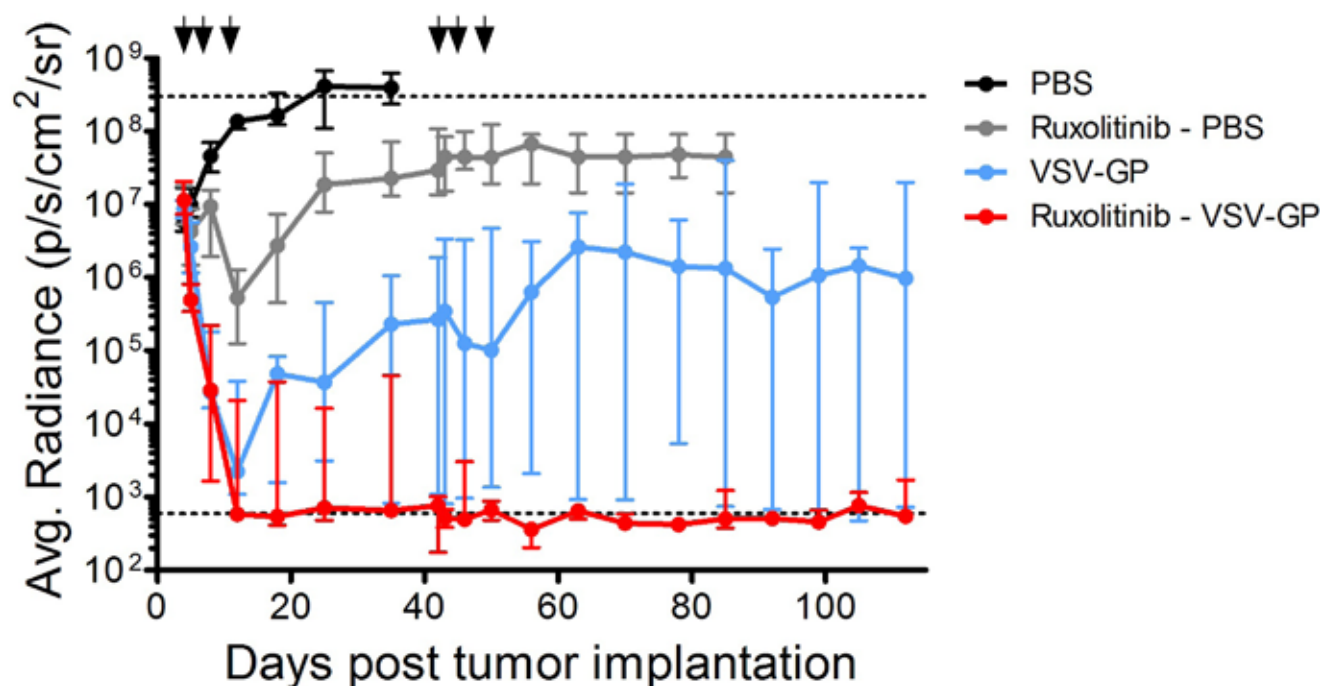

Fig. 2: Oncolytic effect of VSV-GP is enhanced by combination treatment with ruxolitinib in an orthotopic xenograft model. A2780 tumors stably expressing luciferase were established in nude mice by i.p. injection, and treated 4 days later with VSV-GP, ruxolitinib or a combination thereof. At indicated time points mice were analyzed for luciferase signal using bioluminescence imaging.

stomatitis virus pseudotyped with the glycoprotein GP of an arenavirus (LCMV). We are currently working on the development of VSV-GP based vaccines against infectious diseases such as HIV and RSV. We showed that the viral envelope proteins from HIV or RSV are produced at high amounts in infected cells. Additionally, viral envelope proteins are efficiently incorporated into the membrane of newly formed VSV-GP particles. Here, the HIV envelope forms trimers, presenting crucial epitopes for the induction of HIV broadly neutralizing antibodies, e.g. MPER, CD4 binding site, V1V2 loop of gp120. After immunization of mice high titers of antibodies are induced. Currently, we are investigating different heterologous and homologous prime boost regimes. Additionally, we are interested in understanding the competition or potential mutual enhancement of the immune responses to the vaccine antigen and the VSV-GP vector vaccine, with the aim to further improve the efficacy of the VSV-GP vaccine vector.

VSV-GP-Based Oncolytic Cancer Vaccines

Dr. Guido Wollmann

The field of cancer therapy has been experiencing a paradigm shift in recent years due to the impact of immune therapy on long-term remission rates. Oncolytic viruses (OV) that selectively replicate in cancer

cells can directly lyse cancer tissue but, importantly, they can also act in concert with the immune system to induce an antitumor immune response. Our group has generated a particularly effective and safe oncolytic virus, VSV-GP. A number of studies have confirmed successful treatment of various cancer types in mouse models. However, efficacy is mitigated in interferon (IFN) responsive relative to IFN resistant tumors. Accordingly, blockade of the interferon response by ruxolitinib enhanced the

therapeutic efficacy of the VSV-GP treatment in IFN competent tumours (Fig. 2, Dold et al., 2016). Combinations with other immune therapeutics are currently being investigated. In addition, mechanistic studies on the positive and negative effects of viral infection of tumor tissue on the anticancer immune responses are being studied. In parallel, clinical grade virus production and toxicology tests are under way to prepare for first in man studies.

Selected Publications

Application of interferon modulators to overcome partial resistance of human ovarian cancers to VSV-GP oncolytic viral therapy

Dold C, Rodriguez Urbiola C, Wollmann G, Egerer L, Muik A, Bellmann L, Fiegl H, Marth C, Kimpel J, von Laer D. *Molecular Therapy- Oncolytics*; 2016; 3: 16021.

Pre-vaccine era cervical human papillomavirus infection among screening population of women in west Austria

Borena W, Grünberger M, Widschwendter A, Kraxner KH, Marth E, Mayr P, Meier J, Ruth N, Guerrero AT, Marth C, Holm-von Laer D. *BMC Public Health*; 2016; 16: 889.

Low prevalence of HPV detection and genotyping in non-muscle invasive bladder cancer using single-step PCR followed by reverse line blot

Pichler, R., Borena, W., Schäfer, G., Manzl, C., Culig, Z., List, S., Neururer, S., Von Laer, D., Heidegger, I., Klocker, H., Horninger, W., Steiner, H., Brunner, A. *World Journal of Urology*; 2015; 33: S.2.145-51

Complement Component C5 Recruits Neutrophils in the Absence of C3 during Respiratory Infection with Modified Vaccinia Virus Ankara

Philip J. R. Price, Zoltán Bánki, Angelika Scheideler, Heribert Stoiber, Admar Verschoor, Gerd Sutter and Michael H. Lehmann *Journal of Immunology*; 2015; 194: S.1164-1168

Selected Funding

- European HIV Vaccine Alliance, EU-Project, Univ.Prof. Dr. Dorothee von Laer
- VSV system as HIV vaccine, FFG-Bridge, Univ.Prof. Dr. Dorothee von Laer
- Regulatorische T-Zellen, FWF, Univ. Prof. Dr. Heribert Stoiber

Collaborations

- L. Kenner, LBI-CR, AKH, VETMED, Vienna, Austria
- M. Bette, Department of Anatomy, Philipps University Marburg, Germany
- J. Schmitz, B. Haynes; Harvard Medical School, Boston, USA
- A. van den Pol; Yale University, New Haven, USA
- A. Oxenius; ETH Zürich, Zürich, Switzerland
- HP Kiem; Fred Hutchinson Cancer Research Center, Seattle, USA
- J. Bell; CICR - Centre for Innovative Cancer Research, Ottawa, USA
- H. Miletic; University of Bergen, Bergen, Norway
- F. Kreppl; University Ulm, Ulm, Germany
- L. Lehmann; Ludwig-Maximilians-Universität, Munich, Germany

Devices and Services

- BSL-2 and BSL-3 mouse facility, In vivo imaging system (IVIS-PerkinElmer)

Pharmacology



Head of Institute:
Univ.-Prof. Dr. Francesco Ferraguti

Contact:
Peter Mayr Straße 1a
6020 Innsbruck

Francesco.Ferraguti@i-med.ac.at
Phone: +43 512 9003 71204
Fax: +43 512 9003 73200
www.i-med.ac.at/pharmakologie

Research Branch (ÖSTAT Classification)

301206, 301406, 301210,
301401, 301403

Keywords

Neuropeptides, metabotropic glutamate receptors, opioid receptors, neuropeptide Y receptors, fear learning, anxiety disorders, epileptogenesis

Research Focus

- Characterization of the neural networks underlying physiological and pathological fear/anxiety and identification of novel treatment strategies
- Etiology and novel treatment of temporal lobe epilepsy

General Facts

The Department of Pharmacology, established in 1886, is a centre of excellence in Neuro- and Psycho-pharmacology, and uses

a variety of cutting-edge experimental approaches to address fundamental research questions related to the identification of novel molecular targets and the development of new therapeutic concepts for neuropsychiatric disorders.

The Department provides training in pharmacology to both medical undergraduate and graduate students. An additional task of the Institute is to contribute within national and international societies to the promotion of Pharmacology. This is done through the board functions (R. Fischer-Colbrie, Secretary) in the Austrian Pharmacological Society (APHAR) and the organization of the Annual Meeting of the APHAR every 3 years in Innsbruck.

Furthermore, the Department of Pharmacology provides independent drug and therapeutic information to doctors through the "Pharmainformation" bulletin and contributes to a variety of public bodies (e.g. Ethic Committee of the Medical University of Innsbruck) involved in the evaluation of drug safety and development.

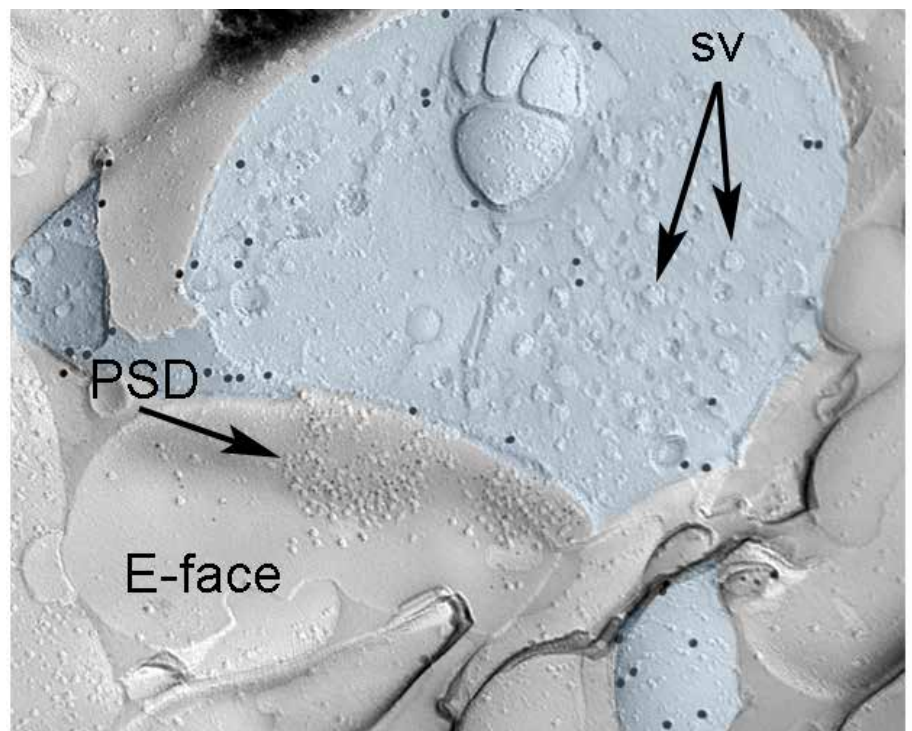

Fig. 1 Synapse made between a thalamic axon terminal and a spine of an intercalated neuron visualized by freeze-fracture replica immunolabelling. The image shows a cross-fractured axon terminal shown in light blue and small portions of its P-face labeled with 15 nm gold particles detecting Channelrhodopsin 2-YFP (ChR2). Within the terminal, the membrane of numerous synaptic vesicles can be observed (sv). The terminal forms an asymmetric synapse with a spine. The postsynaptic membrane specialization (PSD) on the E-face shows a characteristic cluster of intramembrane particles and is labeled with 5 nm gold particles revealing glutamate AMPA-Rs.

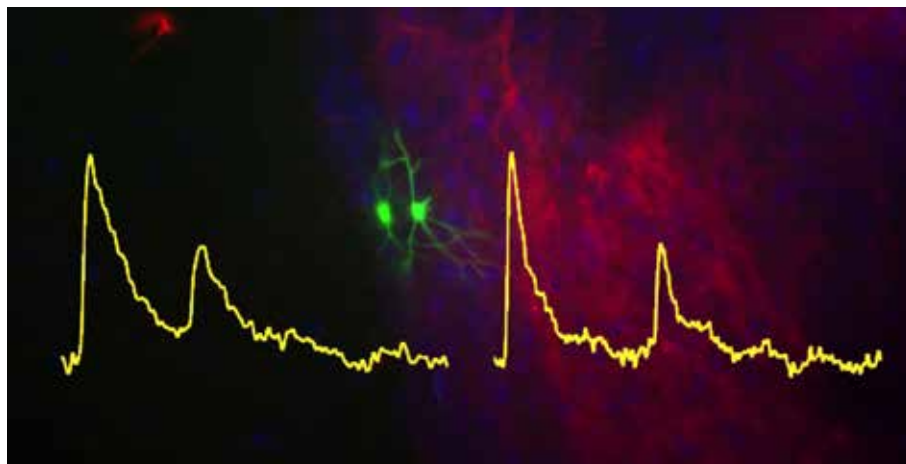

Fig. 2: Recorded and filled neurons of the intercalated cell masses of the amygdala

Research

Neural Circuits underlying Emotional Behaviour

Francesco Ferraguti

The laboratory is primarily interested in understanding the neural mechanisms mediating emotional information processing and the roles that classical neurotransmitters have (e.g. glutamate and GABA receptors) on the acquisition, storage and retrieval of emotional memories in the amygdala.

Although a large body of *in vivo* work has suggested that the encoding and retention of memories for events that signal threat involve specific neuronal activity patterns with characteristic temporal dynamics, the underlying neural networks and their plasticity remain in large part to be elucidated. A first step in understanding these networks is the characterization of the main cell types of the amygdala and the identification of their participation in intrinsic and extrinsic circuitries of this region.

Our work in recent years involved primarily the anatomical, pharmacological and physiological characterization of different GABAergic cell types of the basolateral complex and of the intercalated cell masses of the rodent amygdala. Currently, taking advantage of recent developments in molecular genetics, viral trans-synaptic tracing and novel ultrastructural techniques (e.g. SDS-digested freeze-fracture replica immunogold labelling), we investigate long-range connections between amygdala GABAergic neurons and cortical or subcortical brain structures as well as structural synaptic plasticity of amygdala inhibitory networks.

Moreover, we examine the pharmacological and anatomical bases of anxiety disorders in models of Parkinson's disease. In

particular, we seek to determine whether dopamine-depletion of the amygdala elicits pathological anxiety in mice.

Major Achievements: Identification of novel cell types of the intercalated cell masses of the amygdala and their participation in amygdala neural circuits processing sensory stimuli.

Future Goals: Identification of the neural substrates of social behaviour as well as of the mechanisms of disturbed emotion processing and social interaction.

Neuropeptides in Fear and Anxiety

Ramon Tasan

The laboratory investigates the role of neuropeptides in modulating emotional behaviours that are related to fear and hunger. A further aim is to unravel the underlying synaptic correlates of these emotional responses. Avoiding danger and finding food are two intimately associated, life-sustaining behaviors that are organized in survival circuits and strongly modulated by emotions. Maladaptation within such survival circuits can induce dysregulated, pathological behavior, resulting in the development of feeding- or anxiety-disorders. Interestingly, neuropeptides are essential modulators of both, energy homeostasis and anxiety-related behaviors. For instance, PP-fold peptides, including neuropeptide Y (NPY), peptide YY (PYY) and pancreatic polypeptide (PP) are released during states of hunger or acute danger. While the anxiolytic and fear-reducing properties of these neuropeptides are increasingly evident, a potential interaction of feeding and fear has not been elucidated so far.

Neuropeptides are highly enriched in the amygdala and hippocampus, two brain regions that are fundamentally involved in controlling emotional behaviors. There, they are considered to act as essential mediators significantly shaping synaptic function-

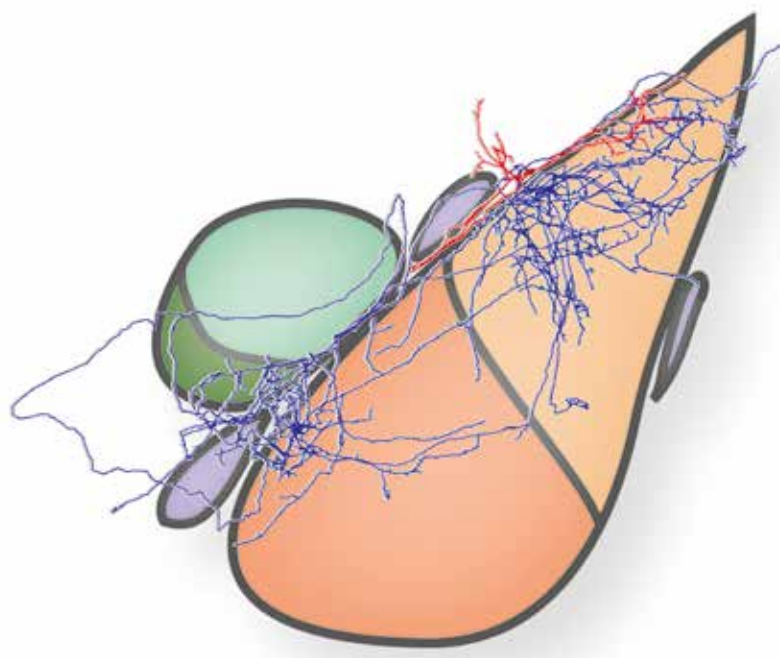

Fig. 3: Axonal projections (shown in blue) of a large intercalated neuron (shown in red) of the amygdala located in the intermediate capsule

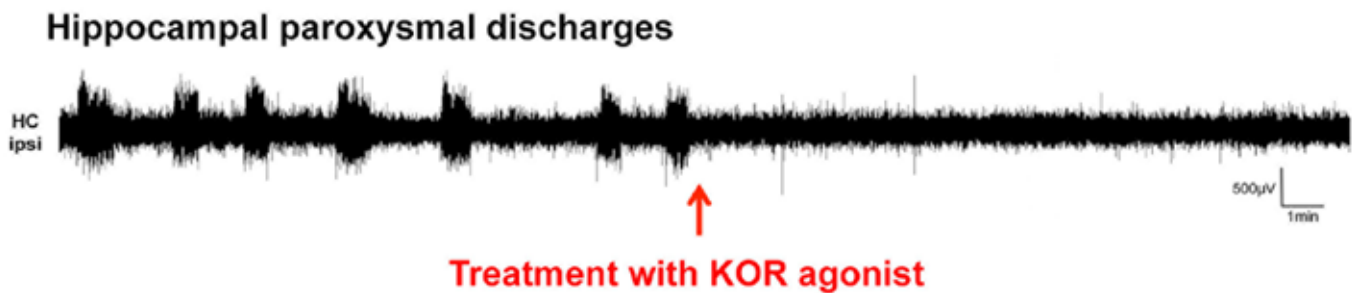

Fig. 4: EEG depth electrode recording from the ipsilateral hippocampus of an epileptic mouse before and after KOR agonist treatment

ing. Through a multidisciplinary approach, which involved immunohistochemistry, neuronal tract tracing, *ex vivo* slice electrophysiology with pharmac- and optogenetic approaches in different transgenic mouse lines, we have demonstrated that several neuropeptides of the gut-brain axis are fundamentally involved in the modulation of fear and fear extinction behaviour, an effect that highly depends on the homeostatic situation of the individual, emphasizing a mutual interaction of survival circuits for fear and hunger.

Major Achievements: Identification of neuropeptides of the gut-brain axis that are also fundamentally involved in the modulation of fear and fear extinction behavior.
Future Goals: Characterization of peripheral modulators of hunger and satiety which could also affect fear learning, closing the loop of the gut-brain axis in controlling emotionally driven behaviors.

Opioid Systems in Epilepsy and Emotional Control

Christoph Schwarzer
 The laboratory investigates the role of the endogenous dynorphin/kappa opioid receptor (KOR) system in epilepsy and epileptogenesis. Moreover, by gaining insight into the functional neuroanatomy of the dynorphin/KOR in emotional control, a further aim is to minimize potential side-effects of KOR agonist treatment.

Epilepsy is one of the most frequent neurological diseases, which presently cannot be cured. A high number of patients are refractory to pharmacological treatment, rendering surgical removal of parts of the brain the ultimate solution. Moreover, epilepsy shows high comorbidity with anxiety and depression.

In recent years, we provided evidence that the activation of KOR plays an important role in epileptogenesis. Thus, dynorphin deficient mice display faster progression and more neurodegeneration in models of

epileptogenesis than wild-type animals. Application of a KOR agonist during epileptogenesis reduces neurodegeneration and neurochemical alterations. On the other hand, activation of KOR is known to induce dysphoria in humans. Applying 4 channel *in vivo* EEG combined with behavioral testing we investigate G-protein biased KOR agonists and AAV based overexpression of dynorphin in the kainic acid model of temporal lobe epilepsy.

Major Achievements: Proof of principle that G-protein biased KOR agonists and AAV based overexpression of dynorphin can suppress seizures without inducing aversion.
Future Goals: Development of novel pharmacological and gene-therapeutical therapies for drug-resistant epilepsy patients.

Neuronal Circuitries of the Subiculum in Epileptogenesis

Meinrad Drexel, Günther Sperk

The group currently investigates the role of GABAergic interneurons of the subiculum in the generation of epileptic seizures. Epileptic seizures are generated by abnormal excessive or synchronous neuronal activity. Malfunctioning of microcircuits of the hippocampus, thalamus or cortex may be causative. Neurophysiological information formed in the hippocampus is processed and transmitted to multiple brain areas. Recently we obtained evidence that malfunctioning of the subiculum, the main output area of the hippocampus, is crucially involved in the generation of epileptic seizures in animal models of temporal lobe epilepsy. In particular GABA/somatostatin and GABA/parvalbumin neurons targeting the dendritic trees and the somata of

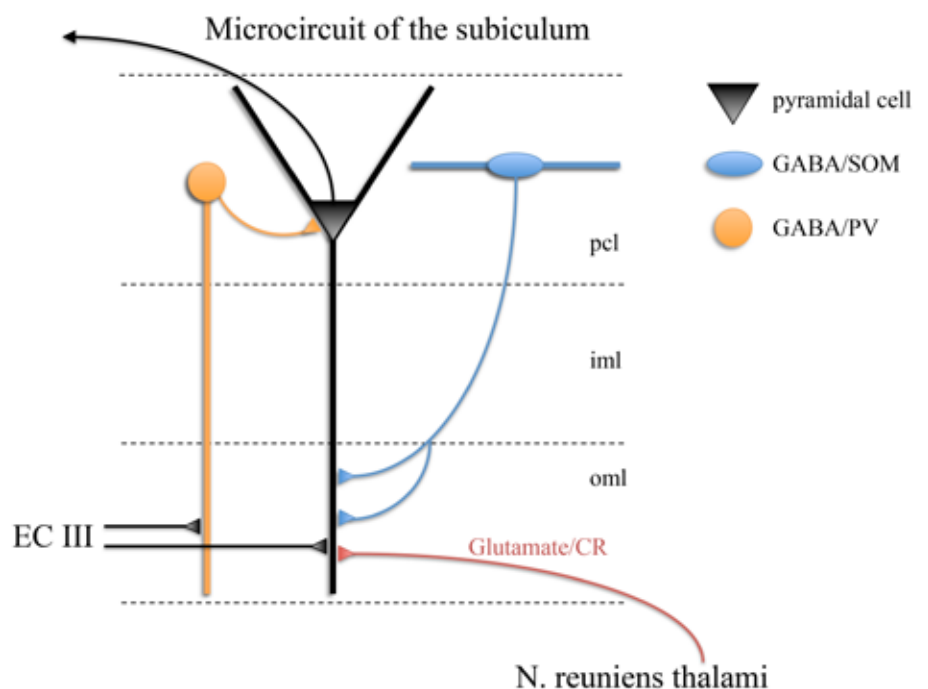

Fig. 5: Microcircuits of the subiculum

pyramidal neurons, respectively, as well as afferent glutamate/calretinin neurons originating in the n. reuniens thalami may be impaired in their function.

We use transgenic mice that allow cell specific overexpression of tetanus toxin introduced by stereotactic injections of a respective viral vector into the subiculum or n. reuniens thalami. Tetanus toxin is then selectively expressed in GABA/somato-stain, GABA/parvalbumin or glutamate/calretinin neurons at the site of injection and impairs neurotransmitter release from these neurons. We are then monitoring EEG activity in these mice for one month and probe development of epilepsy. So far we demonstrated that selective silencing of GABA/parvalbumin neurons in the subiculum leads to spontaneous limbic seizures and highlighted the crucial role of these neurons in the manifestation of temporal lobe epilepsy.

Major Achievements: Identification that selective silencing of GABA/parvalbumin interneurons in the subiculum leads to spontaneous limbic seizures.

Future Goals: Investigate the role of CCK- and calretinin-containing interneurons of the subiculum in the generation of epileptic seizures.

Selected Publications

Sensory Inputs to Intercalated Cells Provide Fear-Learning Modulated Inhibition to the Basolateral Amygdala

Asede, Douglas, Bosch, Daniel, Luethi, Andreas, Ferraguti, Francesco, Ehrlich, Ingrid,
NEURON: 2015; 86: S. 541-554

Regulating anxiety with extrasynaptic inhibition

Botta, Paolo, Demmou, Lynda, Kasugai, Yu, Markovic, Milica, Xu, Chun, Fadok, Jonathan P, Lu, Tingjia, Poe, Michael M., Xu, Li, Cook, James M., Rudolph, Uwe, Sah, Pankaj, Ferraguti, Francesco, Luethi, Andreas,
NATURE NEUROSCIENCE: 2015; 18: S. 1493-+

Hippocampal Theta Input to the Amygdala Shapes Feedforward Inhibition to Gate Heterosynaptic Plasticity

Bazelot, Michael, Bocchio, Marco, Kasugai, Yu, Fischer, David, Dodson, Paul D., Ferraguti, Francesco, Capogna, Marco,
NEURON: 2015; 87: S. 1290-1303

The G-protein biased partial K opioid receptor agonist δ -GNTI blocks hippocampal paroxysmal discharges without inducing aversion

Zangrandi, Luca, Burtscher, Johannes, MacKay, James P, Colmers, William F, Schwarzer, Christoph,
BRITISH JOURNAL OF PHARMACOLOGY: 2016; 173: S. 1756-1767

Pancreatic polypeptide and its central Y-4 receptors are essential for cued fear extinction and permanent suppression of fear

Verma, D., Hoermer, B., Bellmann-Sickert, K., Thieme, V., Beck-Sickinger, A. G., Herzog, H., Sperk, G., Tasan, R. O.,
BRITISH JOURNAL OF PHARMACOLOGY: 2016; 173: S. 1925-1938

Selected Funding

- Signal processing in neurons (SPIN). Austrian Science Fund (FWF) Doctoral college Program no. W12060, F. Ferraguti & C. Schwarzer
- Cell signaling in chronic CNS disorders. Austrian Science Fund (FWF) Sonderforschungsbereich Program no. F44-17, F. Ferraguti
- Plasticity of amygdala intercalated cell microcircuits in fear learning. Austrian Science Fund (FWF) grant no. I2215, F. Ferraguti
- Functional significance of the metabotropic glutamate receptor 1 (mGlu1) splice variants. Austrian Science Fund (FWF) grant no. I2220, F. Ferraguti

Collaborations

- Prof. Aiba A., the University of Tokyo, Tokyo, Japan
- Prof. Becker A., Dept. Neuropathology, University of Bonn, Bonn, Germany
- Prof. Beck-Sickinger A., University of Leipzig, Leipzig, Germany
- Dr. Bonaventure P., Johnson & Johnson Pharmaceutical Research & Development, USA
- Prof. Capogna M., Aarhus University, Copenhagen, Denmark
- Dr. Ehrlich I., University of Tübingen, Tübingen, Germany
- Prof. Heilbronn R., Dept. Virology, Campus Benjamin Franklin, Charité - Medical School, Berlin, Germany
- Prof. Herzog H., Garvan Institute of Medical Research, Australia
- Prof. Lüthi A., Friedrich Miescher Institute, Basel, Switzerland
- Prof. Pape H.C., Westfälische Wilhelms-Universität, Münster, Germany

Medical Statistics and Informatics



Head of Division (interim):
ao. Univ.-Prof. Dr. Hanno Ulmer

Contact:

Schöpfstraße 41/1
6020 Innsbruck

Hanno.Ulmer@i-med.ac.at
Phone: +43 512 9003 70900
Fax: +43 512 9003 73922
www.i-med.ac.at/msig/

Research Branch (Östat Classification)

305907, 305905, 305904,
303026, 303025

Keywords

Medical statistics, biostatistics, statistical methods, epidemiology, medical informatics, medical documentation, clinical trials, registries, Risk Prediction, Prevention

Research Focus

Cardiovascular and Cancer Epidemiology

In cardiovascular and cancer epidemiology, we investigate metabolic and lifestyle factors as potential risk factors for disease incidence and mortality with a special focus on sex/gender related differences.

Statistical and Epidemiological Methods

The focus of the division lies in the development and application of statistical and epidemiological methods for modelling biomedical associations in the framework of causal inference.

Medical Informatics and Documentation

Medical informatics, which is a multidisciplinary research field, targets the use of information technology in order to improve health care.

Biobanking and BioMolecular Resources Research Infrastructure (BBMRI.MUI)

BBMRI.MUI aims to establish a state-of-the-art biobanking infrastructure at the Medical University of Innsbruck and to increase close cooperation between, and harmonization of, local, national and international biobanks.

General Facts

The Division of Medical Statistics and Informatics provides a major contribution to the teaching of medical students. Besides offering obligatory lectures in semesters 1, 5 and 8, we focus on teaching diploma and PhD students. Students who are working on their diploma and PhD theses are advised on the use of appropriate statistical methods.

Additionally, we provide statistical consultations to all researchers of MUI with a focus on clinical studies. We support clinical re-

searchers in all aspects of statistical study planning, protocol writing, applications for ethical review, data management, statistical analysis and publication. We provide expertise regarding the usage of statistical (R, SAS, Stata, SPSS, etc.) and data management software (REDCap). Lalit Kaltenbach has developed an e-CRF system for the international, multicentre LEVOREP trial.

Other multi-centre trials with major participation of our division are the EU-funded Gannet53 randomized controlled trial, as well as other studies such as the BADDHY, PLATA, VITRIS, AFREEZE, ForaC and FlinTIC trials. Marina Popovscaia and Hanno Ulmer are trial statisticians of the international, multicenter phase I and phase II Gannet53 ovarian cancer treatment studies.

The division with Lalit Kaltenbach as responsible IT manager runs five Austria-wide registries: The HIR registry, the PCI registry, the IIK registry, the Ablation registry, and the Parkinson registry. The Austrian societies of Cardiology and Neurology are partners in these projects.

The statistical consulting and the participation in these projects are fundamental for the strong publication record of the division. In relation to the number of employees, the division has a top rank within MUI in recent years regarding total number of publications. In 2015 to 2016, a total of 86 original research papers have been published by researchers of the division (mostly co-authorships). In order to support researchers submitting their PhD and habilitation theses, Joachim Masser developed the SCORE program. It enables the administration of the personal publication record of MUI researchers, including impact factors, citations and journal rankings.

Michael Edlinger (treasurer) and Hanno Ulmer (founding president) have established the Austrian Society of Epidemiology. The society has gained 80 members during the first two years and has been scientifically lively with a wide range of activities including symposia with Hirsch-index > 100 researchers Rick Grobbee, Jaako Tuomilehto and Evout Steyerberg. For further details see <http://www.oegepi.at/>

Research

Cancer Epidemiology

Hanno Ulmer

In cancer epidemiology, we investigate metabolic and lifestyle factors as potential risk factors for cancer incidence and mortality. Metabolic syndrome is a cluster of factors characterized by obesity, hypertension, dyslipidemia and high blood glucose. The

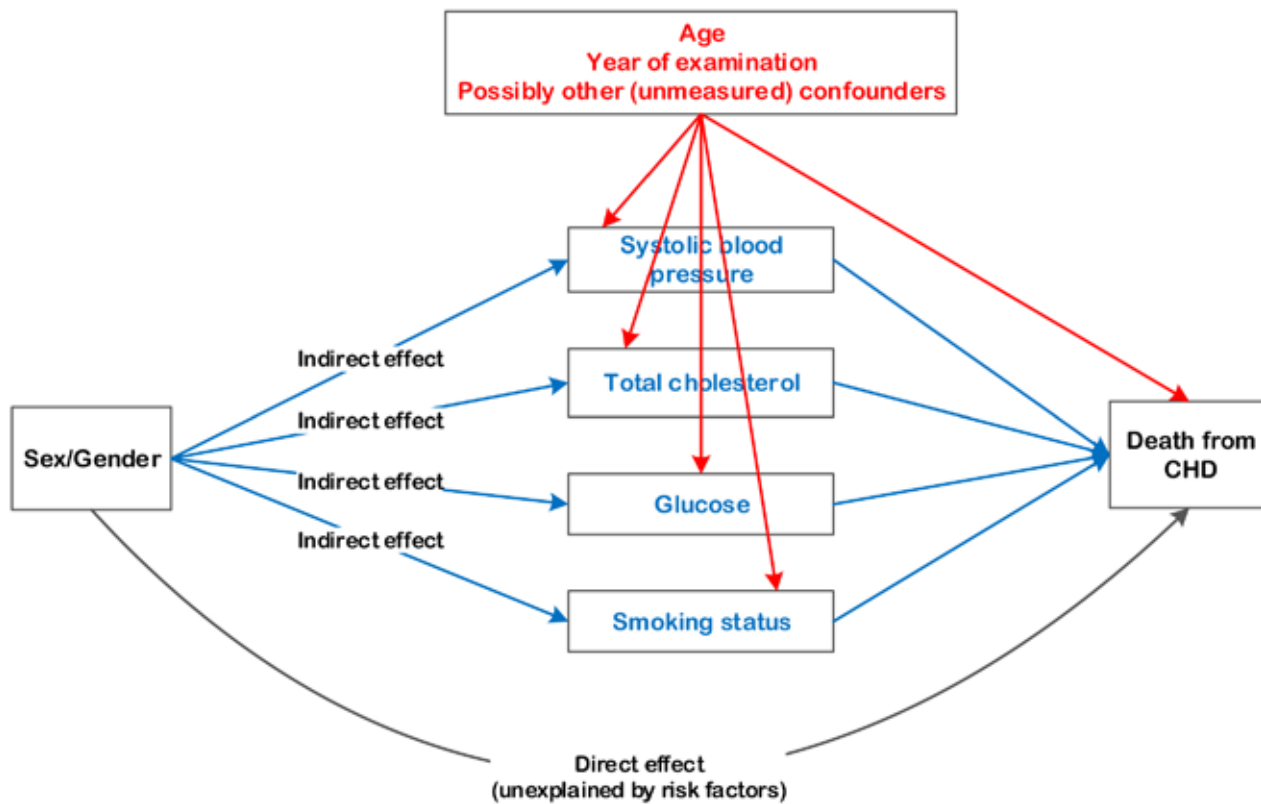

Fig. 1. Path diagram of the relation between sex (exposure), cardiovascular risk factors (mediators), and death from CHD (outcome) in presence of measured (age and year of examination) and unmeasured confounding. CHD = coronary heart disease.

prevalence of metabolic syndrome is rising worldwide. Individuals with metabolic syndrome have a higher risk of cardiovascular diseases and diabetes, but less is known about the association with cancer.

We participated in the Me-Can project, containing a large database with health examination data from about 570,000 individuals from Sweden, Norway and Austria. Measurements such as height, weight, blood pressure, blood glucose, triglycerides and total cholesterol were recorded between 1972 and 2004. Individuals in the database have been followed until their death, emigration or the end of follow-up, according to the principles of epidemiological cohort studies. To obtain cause of death and cancer incidence information, the database was linked to cancer registries in each country. The division is a key partner in the Me-Can project.

More recently, we have set up a case-control study to investigate the association of aluminium exposure and breast cancer. Caroline Linhart is working on this study in cooperation with MUI scientists from the Divisions of Gynaecology, Plastic Surgery and Biochemistry at MUI.

Cardiovascular Epidemiology and Risk factors

Hanno Ulmer

Using data from the population-based Vorarlberg health examination database (VHM&PP), we have been investigating the role of metabolic risk factors such as obesity, blood pressure, blood lipids, blood sugar, gamma-glutamyltransferase or uric acid in cardiovascular disease since 2003. The 2015/2016 publications, in this long tradition, focus on causal relationships between sex/gender, risk factors and coronary heart disease as well as overweight/obesity, risk factors and coronary heart disease. Josef Fritz applied state-of-the-art statistical mediation analysis techniques in order to analyze these relationships from a completely new perspective. In one of the papers, a clear causal explanation is given for the substantial age-dependent differences regarding mortality from coronary heart disease between men and women.

Together with researchers from the Division of Cardiology at MUI, Michael Edlinger is involved in a large clinical cohort study (CARDIIGAN) working on a prediction score for patients undergoing coronary angiography.

Statistical and Epidemiological Methods

Hanno Ulmer

Whereas, over the years, the division had a strong research record in classification and regression methods we are now setting a new focus in the field of causal inference, developing and applying mediation analysis techniques for epidemiologic research problems. By taking into account potential outcomes, so called counterfactuals, these techniques try to uncover the underlying mechanisms and clarify why and how an exposure brings about the outcome of interest. Josef Fritz is currently applying such methods to investigate the contribution of cardiovascular risk factors to the gender gap in mortality from coronary heart disease.

Medical Informatics and Documentation

Georg Göbel

In the division of Medical Statistics and Informatics, we have a strong focus on the use of semantic web technology in order to integrate data repositories and to support medical documentation. Formal, semantically enriched knowledge representation by means of ontologies provides a powerful

solution to facilitate semantic interoperability and knowledge sharing within the scope of e-health, medical documentation, or biobanking. An ontology represents classes of entities of the real world and focuses on the definition of concepts and relations between them. They offer a good solution for addressing the challenge of machine-readable concepts in order to support health care providers and researchers with their daily work.

Sabrina Neururer focuses on ontologized versions of classification systems for health care, especially the formalization of the Austrian procedure catalogue (Österreichischer Leistungskatalog) for health procedure coding. For this, a four-step approach, consisting of a comparative analysis, a definition analysis, a typological analysis, and the ontology implementation was developed. It provides a novel framework to semantically enrich procedure classifications. This approach published bei Neururer et al. [5] is currently re-used and extended in order to serve further research purposes, such as the semantical enrichment of any free-text information. Project proposals focusing on this refinement are currently under review.

The research focus of Philipp Hofer is on the usage of IT-based semantic techniques and (bio-) medical ontologies for biobank data representation. Ontologies are machine-readable and provide a unified, semantic description of sample collections and related data, allowing data integration across heterogeneous biobank catalogues and information systems. For this, he proposed an IT-based, semi-automated concept recommendation within a regional biobank catalog to support and encourage biobank custodians to use ontology concepts and coding standards rather than free text for describing their sample collections.

Biobanking and BioMolecular Resources Research Infrastructure (BBMRI.at)

Georg Göbel

BBMRI.at, an Austrian project, aims to develop a cutting-edge biobanking infrastructure for Austria in order to increase cooperation and harmonization among biobanks and towards industry. Since 2014, the local research team has worked on establishing common guidelines for the collection of human biosamples and on data management

in order to implement a university-wide state-of-the-art biobanking infrastructure at the Medical University of Innsbruck. The project is implemented in strong cooperation with local hospital management Tiro Kliniken. Reference processes based on the CEN Technical Specification for Molecular in vitro diagnostic examinations are currently under development within an inter-institutional working group. They aim to specify pre-examination processes for several different material types such as snap-frozen or FFPE tissue, venous whole blood, serum, plasma, and urine.

Currently, several independent decentralized collections of human biomaterials are located at different MUI divisions. Based on the approval of the local ethics committee, most of these separate sample collections are linked to pseudonymized, detailed clinical data. The project aims at integrating archived biospecimens with clinical and molecular data in a collaborative environment that emphasizes scientific insights, while ensuring security and compliance. An upcoming issue will be the digitalization of FFPE slides. In addition a comprehensive biobank management system will be launched

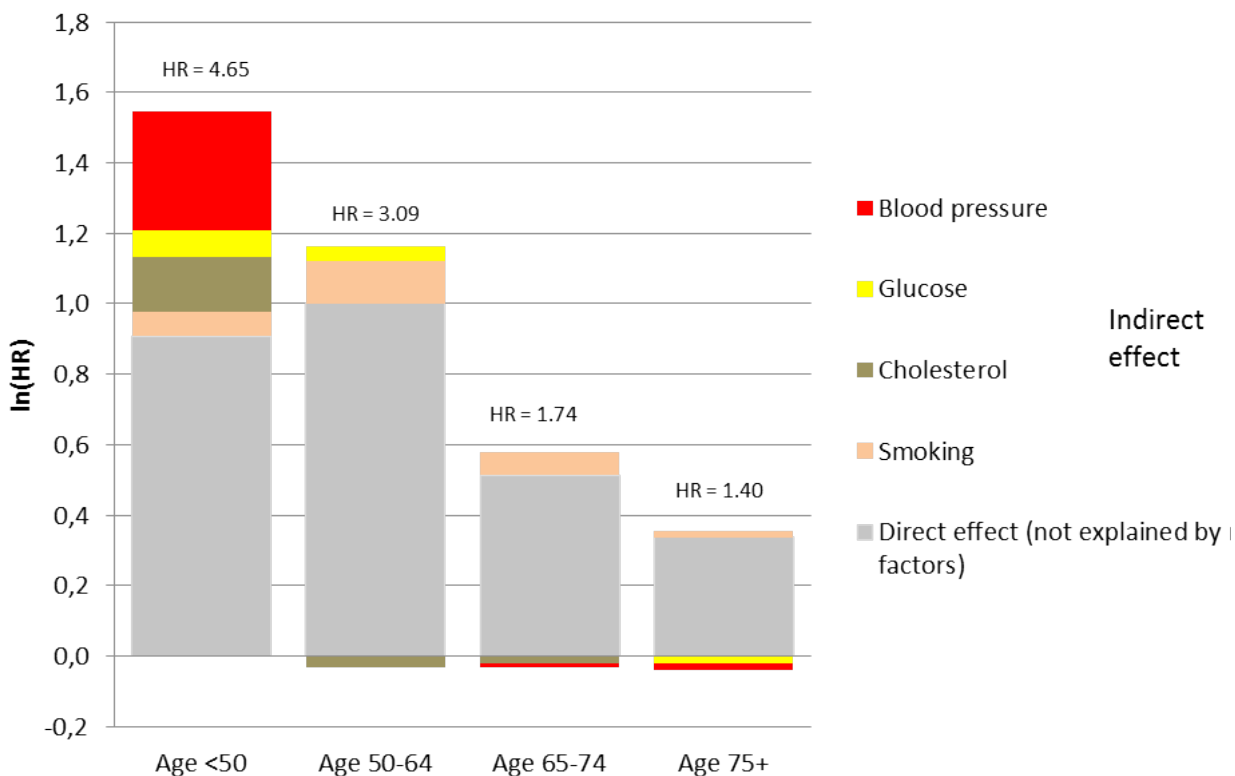

Fig. 2: Direct versus indirect effects of sex on CHD mortality by age group. The direct effect of sex and the indirect ones mediated through the risk factors are displayed as proportions of the estimated age-specific HRs on a logarithmic scale. Values below 0 indicate proportions mediated in favour of men. CHD = coronary heart disease; HR = hazard ratio.

in order to support researchers with collection and sample and quality management tasks. The software will enable users to integrate patient materials, clinical, specimen, genetic and molecular assay data, in order to deliver a holistic, unified view, and facilitates data exploration and hypotheses driven research without extra programming or IT support. Multi-level user access control ensures that all collaborators can work effectively while ensuring compliance with patient consent and maintaining regulatory guidelines.

Selected Publications

Mediation analysis of the relationship between sex, cardiovascular risk factors and mortality from coronary heart disease: Findings from the population-based VHM&PP cohort

Fritz, Josef, Edlinger, Michael, Kelleher, Cecily, Strohmaier, Susanne, Nagel, Gabriele, Concin, Hans, Ruttman, Elfriede, Hochleitner, Margarethe, Ulmer, Hanno, *ATHEROSCLEROSIS*: 2015; 243: S. 86-92

A strong interaction between age and overweight/obesity on the risk of coronary heart disease in the context of metabolic mediation.

Fritz J, Strohmaier S, Nagel G, Concin H, Ulmer H, *EPIDEMIOLOGY*: 2016; 27(3): S. 13-4

Metabolic risk score and cancer risk: pooled analysis of seven cohorts

Stocks, Tanja, Bjorge, Tone, Ulmer, Hanno, Manjer, Jonas, Haggstrom, Christel, Nagel, Gabriele, Engeland, Anders, Johansen, Dorthe, Hallmans, Goran, Selmer, Randi, Concin, Hans, Tretli, Steinar, Jonsson, Hakan, Stattin, Par, *INTERNATIONAL JOURNAL OF EPIDEMIOLOGY*: 2015; 44: S. 1353-1387

Semi-automated evaluation of biomedical ontologies for the biobanking domain based on competency questions

Hofer, Philipp; Neururer, Sabrina; Hauffe, Helga; Insam, Thomas; Zeilner, Anette; Göbel, Georg, *STUDIES IN HEALTH TECHNOLOGY AND INFORMATICS*: 2015; 212; S. 65-72

Collaborations

- Odd Aalen, University of Oslo, Oslo, Norway
- Tone Bjørge, Bergen University, Bergen, Norway
- Larry Brant, National Institute on Aging, Baltimore MD, USA
- Hans Concin, Arbeitskreis für Vorsorge- und Sozialmedizin, Bregenz, Austria
- John Danesh, University of Cambridge, Cambridge, UK
- Rick Grobbee, University Medical Centre Utrecht, Utrecht, the Netherlands
- Leo Held, University of Zurich, Zurich, Switzerland
- Cecily Kelleher, University College Dublin, Dublin, Ireland
- Yuan Lu, Harvard University, Cambridge MA, USA
- Anna Lukanova, German Cancer Research Centre, Heidelberg, Germany
- Jonas Manjer, Lund University, Malmö, Sweden
- Gabriele Nagel, University of Ulm, Ulm, Germany,
- Petra Peeters, Imperial College, London, UK
- Ruth Pfeiffer, National Cancer Institute, Bethesda MD, USA
- Pär Stattin, Umeå University, Umeå, Sweden
- Ewout Steyerberg, Erasmus MC University Medical Centre Rotterdam, Rotterdam, the Netherlands
- Reinhild Strauss, Medical University of Vienna, Vienna, Austria
- Jaakko Tuomilehto, University of Helsinki, Helsinki, Finland
- Christopher Wild, International Agency on Research of Cancer, Lyon, France
- Kurt Zatloukal, Medizinische Universität Graz, Austria

General Pathology



Head of Division (interim):
ao. Univ.-Prof.ⁱⁿ Dr.ⁱⁿ Bettina Zelger

Contact:
Müllerstraße 44
6020 Innsbruck

Bettina.Zelger@i-med.ac.at
Phone: +43 512 9003 71301
Fax: +43 512 9003 73301
www.i-med.ac.at/pathologie

Research Branch (ÖSTAT Classification)

301301, 301108, 301103, 302013

Keywords

Oncology, uropathology, haematopathology, gastrointestinal pathology, oropharyngeal pathology, pathology of infections, immunology, transplantation, biobanking, morphomics, digital pathology

Research Focus

- Oncology
- Infectiology, immunology and transplantation
- Biobanking, morphomics, digital pathology

General Facts

The Division of General Pathology focusses on diagnostic clinical pathology and was responsible for the routine pathological diagnosis of biopsies and surgical specimens obtained from most of the Clinical Departments of the Medical University of Innsbruck with an emphasis on oncology, especially of the lymphatic tissue, the urogenital tract and oropharyngeal tumors. A

biobank consisting of formalin-fixed paraffin-embedded material (FFPE) is located at our division thus making us an important connecting link between basic science and clinical research. This translational research is reflected by a close cooperation with clinicians and researchers in the fields of oncology, surgery, radiology, nuclear medicine, head & neck as well as cranio-maxillofacial surgery, dermatology and other departments.

Research

Oncology

Main topics are the diagnosis of rare tumour entities, tumour biology and mechanisms of treatment resistance, evaluation of biomarkers to predict individual risk and prog-

nosis, support diagnosis and assistance in treatment allocation as well as identification of potential therapeutic targets using molecular pathological methods. Current projects deal with the early detection of lung cancer and the role of molecular pathology for therapy in lung cancer patients.

The research groups for uropathology, haematopathology and cranial-maxillofacial surgery represent a particular field of interest at our division and are therefore highlighted separately.

1) Uropathology

The main topic in the field of uropathology is prostate cancer focusing on tumour biology, mechanisms of treatment resistance, evaluation of biomarkers for diagnosis, risk

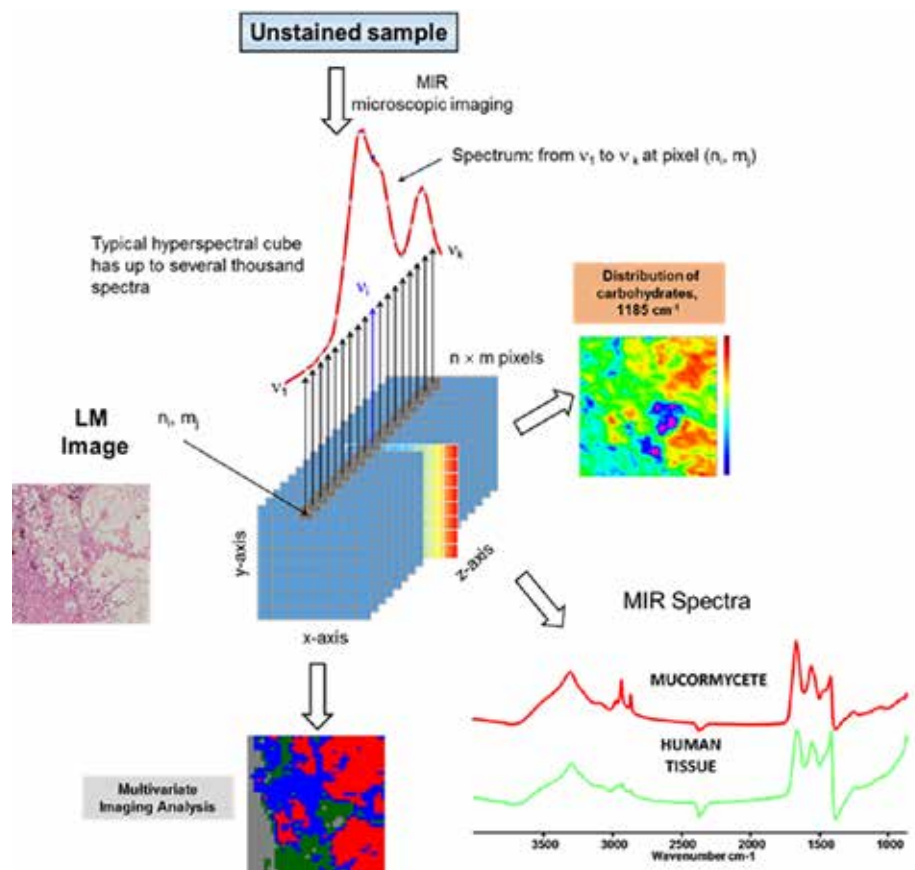

Fig. 1: Schematic illustration of a model of hyperspectral images and the morphological integrity after IR imaging measurements of mucormycosis in a human tissue section. A single acquisition of an unstained sample records thousands of images across numerous wavelengths, resulting in an image stack forming a three-dimensional (3D) image data cube. The challenges to analyze IR imaging data are that: (a) the obtained image data cube may be viewed as spatially located spectra, with the processing tools of classical spectroscopy being applied to single spectra; (b) the data may be viewed as images, with image-processing tools being used to extract higher-quality spatial information. Thus, the combination of IR imaging, signal and image processing, and histomorphological investigations makes IR imaging a multidisciplinary method.

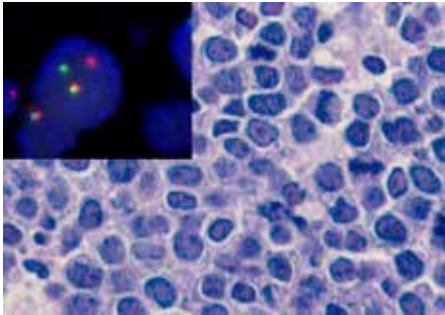

Fig. 2: Lymph node infiltration by an aggressive B-cell-lymphoma (H&E; 40x) harbouring a C-MYC rearrangement (see inset: the fusion signal represents an intact C-MYC, the single orange and green signal indicates a rearrangement - dual color break apart probe for C-MYC)

prognosis and therapy allocation as well as potential therapeutic targets. Furthermore the function of the androgen receptor and the role of stem cells, cytokines and inflammation in tumour progression and treatment resistance are evaluated in close cooperation with the Department of Urology. Another field of interest is bladder cancer, currently concentrating on tumour immunology and especially the role of the PD1/PDL1 axis in advanced and metastasized bladder cancer. Further projects concentrate on biomarkers for risk, prognosis and resistance to BCG-therapy as well as the prevalence of HPV infection in superficial bladder cancer.

2) Haematopathology

The main field of interest is the pathology of malignant lymphomas, focusing on autophagy and the immune microenvironment including the PD1/PDL1 axis in B-cell-neoplasias (multiple myeloma, follicular lymphoma) as well as the morphology, immune phenotype and molecular pathology (MYD88 and CXCR4 mutations) of lymphoplasmacytic/plasmacytoid lymphomas. A current project deals with aggressive B-cell-lymphomas including immune microenvironment, potential prognostic biomarkers, such as C-MYC translocations and therapeutic targets such as PD1 and PDL1. In addition, a wide number of clinical studies are provided with tumour samples from our biobank of FFPE specimens.

3) Cranio-Maxillofacial Pathology

This project aims at the application and integration of clinical, molecular pathological, molecular imaging (MALDI-IMS, FTIR imaging and μ CT), bioinformatics and protein identification technologies to identify mo-

lecular signatures allowing the stratification of patients who are susceptible to curative treatment of oral squamous cell carcinoma. Patient samples that have been and are still being collected at the Department for Cranio-Maxillo-Facial and Oral Surgery and at the Department of Pathology (biobank) will be systematically collected, dissected, and prepared to be accessible for this study.

Infectiology, Immunology and Transplantation

The main topics include morphology and immune phenotype of the inflammatory infiltrate of composite allograft transplantations and limb transplantation in animal experiments in close cooperation with the Department of Surgery, Medical University of Innsbruck.

Further fields of attention are the immunology and new therapeutic approaches in chronic inflammatory bowel disease in close cooperation with the Department of Endocrinology, Gastroenterology and Metabolic Diseases and the morphology of cutaneous vasculitis in cooperation with the Department of Dermatology and Venerology. Another ongoing project deals with the evaluation of new methods of detection of mycoses from blood and tissue using PCR based methods and molecular imaging techniques (mid-infrared microscopic) in cooperation with the Department of Hygiene, Microbiology and Social Medicine as well as the Institute of Forensic Medicine.

Biobanking, Morphomics, Digital Pathology

Our department operates on a large biobank of FFPE-specimens. In addition frozen tissue (FT) from urological cancers (prostate, bladder, kidney) as well as other cancer types (breast, colon) are stored for research purposes. DNA-Extraction of FFPE and FT is offered as are further molecular pathological analyses. Equipment also includes a scanning unit for slide evaluation. To further strengthen our morphomics unit we participated in the "HRSM-application 2016" in close cooperation with the Medical Universities of Vienna and Graz and the University of Veterinary Medicine Vienna, which was positively evaluated.

Selected Publications

Vasculitic wheel - an algorithmic approach to cutaneous vasculitides

Ratzinger, Gudrun, Zelger, Bettina Gudrun, Carlson, J. Andrew, Burgdorf, Walter, Zelger, Bernhard, JOURNAL DER DEUTSCHEN DERMATOLOGISCHEN GESELLSCHAFT: 2015; 13: S. 1092-1117

Pulmonary mucinous adenocarcinomas: architectural patterns in correlation with genetic changes, prognosis and survival

Geles, Abidin, Gruber-Moesenbacher, Ulrike, Quehenberger, Franz, Manzl, Claudia, Al Effah, Mohamed, Grygar, Elisabeth, Juettner-Smolle, Freyja, Popper, Helmut H., VIRCHOWS ARCHIV: 2015; 467: S. 675-686

Low Beclin-1 expression predicts improved overall survival in patients treated with immunomodulatory drugs for multiple myeloma and identifies autophagy inhibition as a promising potentially druggable new therapeutic target: an analysis from The Austrian Myeloma Registry (AMR)

Willenbacher, Wolfgang, Thangavadeivel, Shanmugapriya, Greil, Richard, Willenbacher, Ella, Weger, Roman, Manzl, Claudia, Joehrer, Karin, Brunner, Andrea, LEUKEMIA & LYMPHOMA: 2016; 57: S. 2330-2341

Tumor-infiltrating immune cell subpopulations influence the oncologic outcome after intravesical bacillus calmette-guèrin therapy in bladder cancer

Pichler, Renate, Fritz, Josef, Zavadi, Claudia, Schaefer, Georg, Culig, Zoran, Brunner, Andrea, ONCOTARGET: 2016; 7: S. 39916-39930

Distinct galactofuranose antigens in the cell wall and culture supernatants as a means to differentiate Fusarium from Aspergillus species

Wiedemann, Annegret, Kakoschke, Tamara Katharina, Speth, Cornelia, Rambach, Guenter, Ensinger, Christian, Jensen, Henrik Eivang, Ebel, Frank, INTERNATIONAL JOURNAL OF MEDICAL MICROBIOLOGY: 2016; 306: S. 381-390

Selected Funding

- The pattern of immune cell infiltration in DLBCL, NOS: Detecting differences between molecular lymphoma subtypes as a target for rational treatment allocation; Firma Celgene; Assoz. Prof. PD Dr. Andrea Brunner-Véber (Pathology)/Dr. Ella Willenbacher (Hematology)
- Novel biomarkers in predicting response to intravesical Bacillus Calmette-Guèrin (BCG) therapy in high-risk, non-muscle invasive bladder cancer (NMIBC); Medizinischer Forschungsfonds Tirol (MFF); Dr. Renate Pichler (Urology)/Assoz. Prof. PD Dr. Andrea Brunner-Véber (Pathology)
- HRSM - Kooperationsausschreibung 2016 Teilbereich Forschung EK; Bundesministerium für Wissenschaft und Forschung; Ao. Univ. Prof. Dr. Bettina Zelger/Assoz. Prof. PD Dr. Georg Göbel/Dr. Georg Schäfer/MMag. Dr. Johannes Pallua PhD

Collaborations

- Prof. Dr. Martina Prelog, Department of Pediatrics, University of Würzburg, Würzburg, Germany
- Kooperation mit den Medizinischen Universitäten Wien und Graz, sowie der Veterinärmedizinischen Universität Wien im Rahmen des Hochschulrauminfrastrukturtrages (HRSM) 2016

Legal Medicine



Head of Institute:
o. Univ.-Prof. Dr. Richard Scheithauer

Contact:
Müllerstraße 44
6020 Innsbruck

gmi@i-med.ac.at
Phone: +43 512 9003 70600
Fax: +43 512 9003 73600
www.gmi.eu

Research Branch (ÖSTAT Classification)

301206, 301902, 106006,
301110, 106041

Keywords

Forensic genetics, genetic identification, next generation sequencing, cell line identification, forensic DNA phenotyping, disaster victim identification, forensic toxicology, drug screening, therapeutic monitoring, metabolomics

Research Focus

The Institute of Legal Medicine (GMI) at the Medical University of Innsbruck harbours the Austrian Central DNA Laboratory that was established in 1997. It represents Austria in the European DNA Profiling Group (EDNAP), the Network of Forensic Science Institutes (ENFSI), and the Interpol Monitoring Expert Group (MEG). The GMI has a strong focus on technology-based projects involving electrophoresis, real-time PCR, mass spectrometry, and massive parallel sequencing (MPS) strategies. The GMI is repeatedly consigned to handle international casework requests, some of which received international media attention, such as the

identification of the 2004 South Asian Tsunami victims (Sri Lanka), the missing children of the Russian Tsar family Romanov, the 1973 victims of the regime in Chile, the 2014 missing students from Ayotzina-pa, Mexico, and diverse international crime cases.

The GMI harbours the mitochondrial (mt) DNA database EMPOP (<http://empop.online/>) that over the years has become the primer reference for forensic mtDNA databasing and quality control of mtDNA data. The GMI also hosts the autosomal STR database STRidER that provides freely-available, quality-controlled STR allele frequencies to the scientific community (<http://strider.online/>). Furthermore, the GMI has demonstrated experience in assay design and development for the NGS analysis by first publishing mitochondrial DNA NGS applications on the PGM (Parson *et al.* 2013) and first PCR multiplex assays for mitogenome NGS of degraded forensic samples (Parson *et al.* 2015) as well as development and application of large SNP multiplexes for human identification (Mayr-Eduardoff *et al.* 2015) and ancestry informative analysis (Mayr-Eduardoff *et al.* 2016). The GMI is the host of the Core Facility Metabolomics.

Research

Paradigm Change? Moving Forensic Genetics to Highly Sensitive and More Discriminatory Analysis by Next Generation Sequencing (NGS)

Walther Parson

The institute plays an international key role in addressing relevant issues in Forensic Human Identification using Next Generation Sequencing techniques.

Increasing the Discrimination Power of Forensic Mitochondrial DNA Analysis by Mitogenome Sequencing

Walther Parson

The institute is leading international research to maximize the forensically relevant information content from mitochondrial DNA sequencing from unknown samples (crime scenes and human identification) using Next generation Sequencing technologies.

Forensic DNA Phenotyping: Providing Evidentiary Leads by Predicting Externally Visible Characteristics and Bio-Geographical Origin by DNA Analysis

Walther Parson

Unknown perpetrators of crime cannot be identified with the current forensic use of DNA without a reference samples. We over-

come this major limitation by developing prototype tools for predicting appearance, age, and ancestry from DNA traces. This allows the construction of composite sketches of unknown trace donors directly from their traces left behind at crime scenes.

Core Facility Metabolomics

Herbert Oberacher

The mission of the Core Facility Metabolomics is to serve as an enabling resource for research and development programs at the Medical University of Innsbruck. We aim to provide expertise and state-of-the-art technologies for the qualitative and quantitative analysis of small bioorganic molecules. Common targets are drugs, pharmaceuticals, endogenous compounds, and metabolites thereof included in all kinds of biological samples (e.g. biofluids, cells, tissues).

Systematic Toxicological Analysis (STA)

Herbert Oberacher

STA is defined as the application of an adequate analytical strategy for the detection and identification of as many as possible potentially toxic compounds and their metabolites in biological samples. It is an integral part of the medicolegal examination of drug consume and poisoning. To maximize the forensically relevant information obtained from casework samples, we are developing new and advanced workflows for STA.

Drug Checking

Herbert Oberacher

Drug checking is a harm reduction service that helps users avoid ingesting unknown and potentially dangerous substances and adulterants found in street drugs. Furthermore, drug checking services assist in identifying trends in illicit drug markets. We support the local drug checking initiative run by "Drogenarbeit Z6", and the Ministry of Health with our expertise in drug analysis. Furthermore, to facilitate and accelerate the compound identification process, we are developing new and advanced tools such as mass spectral libraries.

Wastewater Analysis

Herbert Oberacher

Wastewater analysis is a rapidly developing scientific discipline with the potential for monitoring real-time data on geographical and temporal trends in illicit drug use. It involves sampling a source of wastewater, such as a sewage influent to a wastewater treatment plant. Monitoring the effluent of wastewater treatment plants is of importance in environmental research. Comprehensive analysis provides information on



Fig. 1: Eric Pokorak (Unit Chief, Mitochondrial DNA Unit, FBI) & Douglas Hares (Custodian of the US National DNA Database, FBI) visit the Institute of Legal Medicine (Prof. Richard Scheithauer, Prof. Walther Parson) for collaboration on mtDNA interpretation.

the fate of potential surface and ground water pollutants. To maximize the information obtained from water samples, we are developing new and advanced workflows for the qualitative and quantitative analysis of drugs and their transformation products in wastewater.

Selected Publications

Recommendations of the DNA Commission of the International Society for Forensic Genetics (ISFG) on quality control of autosomal Short Tandem Repeat allele frequency databasing (STRiDER)

Bodner, Martin, Bastisch, Ingo, Butler, John M., Fimmers, Rolf, Gill, Peter, Gusmao, Leonor, Morling, Niels, Phillips, Christopher, Prinz, Mechthild, Schneider, Peter M., Parson, Walther, FORENSIC SCIENCE INTERNATIONAL-GENETICS: 2016; 24: S. 97-102

Massively parallel sequencing of forensic STRs: Considerations of the DNA commission of the International Society for Forensic Genetics (ISFG) on minimal nomenclature requirements

Parson, Walther, Ballard, David, Budowle, Bruce, Butler, John M., Gettings, Katherine B., Gill, Peter, Gusmao, Leonor, Hares, Douglas R., Irwin, Jodi A., King, Jonathan L., de Knijff, Peter, Morling, Niels, Prinz, Mechthild, Schneider, Peter M., Van Neste, Christophe, Willuweit, Sascha, Phillips, Christopher, FORENSIC SCIENCE INTERNATIONAL-GENETICS: 2016; 22: S. 54-63

D5S2500 is an ambiguously characterized STR: Identification and description of forensic microsatellites in the genomics age

Phillips, C., Parson, W., Amigo, J., King, J. L., Coble, M. D., Steffen, C. R., Vallone, P. M., Gettings, K. B., Butler, J. M., Budowle, B., FORENSIC SCIENCE INTERNATIONAL-GENETICS: 2016; 23: S. 19-24

Helena, the hidden beauty: Resolving the most common West Eurasian mtDNA control region haplotype by massively parallel sequencing an Italian population sample
Bodner, Martin, Iuvano, Alessandra, Strobl, Christina, Nagl, Simone, Huber, Gabriela, Pelotti, Susi, Pettener, Davide, Luiselli, Donata, Parson, Walther, FORENSIC SCIENCE INTERNATIONAL-GENETICS: 2015; 15: S. 21-26

Mitochondrial DNA heteroplasmy in the emerging field of massively parallel sequencing

Just, Rebecca S., Irwin, Jodi A., Parson, Walther, FORENSIC SCIENCE INTERNATIONAL-GENETICS: 2015; 18: S. 131-139

Full mtGenome reference data: Development and characterization of 588 forensic-quality haplotypes representing three US populations

Just, Rebecca S., Scheible, Melissa K., Fast, Spence A., Sturk-Andreaggi, Kimberly, Roeck, Alexander W., Bush, Jocelyn M., Higginbotham, Jennifer L., Peck, Michelle A., Ring, Joseph D., Huber, Gabriela E., Xavier, Catarina, Strobl, Christina, Lyons, Elizabeth A., Diegoli, Toni M., Bodner, Martin, Fendt, Liane, Kralj, Petra, Nagl, Simone, Niederwieser, Daniela, Zimmermann, Bettina, Parson, Walther, Irwin, Jodi A., FORENSIC SCIENCE INTERNATIONAL-GENETICS: 2015; 14: S. 141-155

Evidence for frequent and tissue-specific sequence heteroplasmy in human mitochondrial DNA

Naue, Jana, Horer, Steffen, Sanger, Timo, Strobl, Christina, Hatzer-Grubwieser, Petra, Parson, Walther, Lutz-Bonengel, Sabine, MITOCHONDRION: 2015; 20: S. 82-94

Massively parallel sequencing of complete mitochondrial genomes from hair shaft samples

Parson, Walther, Huber, Gabriela, Moreno, Lilliana, Madel, Maria-Bernadette, Brandhagen, Michael D., Nagl, Simone, Xavier, Catarina, Eduardoff, Mayra, Callaghan, Thomas C., Irwin, Jodi A., FORENSIC SCIENCE INTERNATIONAL-GENETICS: 2015; 15: S. 8-15

Hairy matters: MtDNA quantity and sequence variation along and among human head hairs

Desmyter, Stijn, Bodner, Martin, Huber, Gabriela, Dognaux, Sophie, Berger, Cordula, Noel, Fabrice, Parson, Walther, FORENSIC SCIENCE INTERNATIONAL-GENETICS: 2016; 25: S. 1-9

Ancient mtDNA sequences from the First Australians revisited

Heupink, Tim H., Subramanian, Sankar, Wright, Joanne L., Endicott, Phillip, Westaway, Michael, Carrington, Huynen, Leon, Parson, Walther, Millar, Craig D., Willerslev, Eske, Lambert, David M., PROCEEDINGS OF THE NATIONAL ACADEMY OF SCIENCES OF THE UNITED STATES OF AMERICA: 2016; 113: S. 6892-6897

Inter-laboratory evaluation of SNP-based forensic identification by massively parallel sequencing using the Ion PGM (TM)

Eduardoff, M., Santos, C., de la Puente, M., Gross, T. E., Fondevila, M., Strobl, C., Sobrino, B., Ballard, D., Schneider, P. M., Carracedo, A., Lareu, M. V., Parson, W., Phillips, C., FORENSIC SCIENCE INTERNATIONAL-GENETICS: 2015; 17: S. 110-121

Evaluation of DNA Variants Associated with Androgenetic Alopecia and Their Potential to Predict Male Pattern Baldness

Marcinska, Magdalena, Pospiech, Ewelina, Abidi, Sarah, Andersen, Jeppe Dyrberg, van den Berge, Margreet, Carracedo, Angel, Eduardoff, Mayra, Marczakiewicz-Lustig, Anna, Morling, Niels, Sijen, Titia, Skowron, Malgorzata, Soechtig, Jens, Syndercombe-Court, Denise, Weiler, Natalie, Schneider, Peter M., Ballard, David, Borsting, Claus, Parson, Walther, Phillips, Chris, Branicki, Wojciech, EUROFORGEN-NOE Consortium, PLOS ONE: 2015; 10: S. e0127852

Evaluation of the predictive capacity of DNA variants associated with straight hair in Europeans

Pospiech, Ewelina, Karlowska-Pik, Joanna, Marcinska, Magdalena, Abidi, Sarah, Andersen, Jeppe Dyrberg, van den Berge, Margreet, Carracedo, Angel, Eduardoff, Mayra, Freire-Aradas, Ana, Morling, Niels, Sijen, Titia, Skowron, Malgorzata, Soechtig, Jens, Syndercombe-Court, Denise, Weiler, Natalie, Schneider, Peter M., Ballard, David, Borsting, Claus, Parson, Walther, Phillips, Chris, Branicki, Wojciech, EUROFORGEN-NOE Consortium, FORENSIC SCIENCE INTERNATIONAL-GENETICS: 2015; 19: S. 280-288

Forensic ancestry analysis with two capillary electrophoresis ancestry informative marker (AIM) panels: Results of a collaborative EDNAP exercise

Santos, C., Fondevila, M., Ballard, D., Banemann, R., Bento, A. M., Borsting, C., Branicki, W., Brisighelli, F., Burrington, M., Capal, T., Chaitanya, L., Daniel, R., Decrocy, V., England, R., Gettings, K. B., Gross, T. E., Haas, C., Harteveld, J., Hoff-Olsen, P., Hoffmann, A., Kayser, M., Kohler, P., Linares, A., Mayr-Eduardoff, M., McGovern, C., Morling, N., O'Donnell, G., Parson, W., Pascali, V. L., Porto, M. J., Roeth, A., Schneider, P. M., Sijen, T., Stenzl, V., Court, D. Syndercombe, Templeton, J. E., Turanska, M., Vallone, P. M., van Oorschot, R. A. H., Zatkalikova, L., Carracedo, A., Phillips, C., EUROFORGEN-NOE Consortium, FORENSIC SCIENCE INTERNATIONAL-GENETICS: 2015; 19: S. 56-67

Current status of non-targeted liquid chromatography-tandem mass spectrometry in forensic toxicology

Oberacher, Herbert, Arnhard, Kathrin, TRAC-TRENDS IN ANALYTICAL CHEMISTRY: 2016; 84: S. 94-105.

Compound identification in forensic toxicological analysis with untargeted LC-MS-based techniques

Oberacher, Herbert, Arnhard, Kathrin, BIOANALYSIS: 2015; 7: S. 2825-2840

Analytical Validation of a Portable Mass Spectrometer Featuring Interchangeable, Ambient Ionization Sources for High Throughput Forensic Evidence Screening

Lawton, Zachary E., Traub, Angelica, Fatigante, William L., Mancias, Jose, O'Leary, Adam E., Hall, Seth E., Wieland, Jamie R., Oberacher, Herbert, Gizzi, Michael C., Mulligan, Christopher C., JOURNAL OF THE AMERICAN SOCIETY FOR MASS SPECTROMETRY: 2016; Epub ahead of print: S.

Combining a portable, tandem mass spectrometer with automated library searching - an important step towards streamlined, on-site identification of forensic evidence

O'Leary, Adam E., Oberacher, Herbert, Hall, Seth E., Mulligan, Christopher C., ANALYTICAL METHODS: 2015; 7: S. 3331-3339

Successful adaption of a forensic toxicological screening workflow employing nontargeted liquid chromatography-tandem mass spectrometry to water analysis

Steger, Julia, Arnhard, Kathrin, Haslacher, Sandra, Geiger, Klemens, Singer, Klaus, Schlapp, Michael, Pitteri, Florian, Oberacher, Herbert, ELECTROPHORESIS: 2016; 37: S. 1085-1094

Selected Funding

European project:
DNASEQEX - DNA-STR Massive Sequencing & International Information Exchange, funded by the European Commission, Coordinator: National Institute of Toxicology and Forensic Sciences - Madrid (I. A. Alonso), GA No. HOME/2014/ISFP/AG/LAWX/ 400007135, 2016-2018. MUI is coordinating technological platforms

Collaborations

- Institute of Mathematics, University Innsbruck, Innsbruck, Austria
- Institut Geschichtswissenschaften / Europäische Ethnologie, University Innsbruck, Innsbruck, Austria
- Zentralinstitut für Bluttransfusion und Immunologische Abteilung, Tirol Kliniken, Innsbruck, Austria
- Armed Forces DNA Identification Laboratory, Rockville, USA
- Bundeskriminalamt Wiesbaden, Wiesbaden, Germany
- Institut für Veterinärpathologie, University Giessen, Giessen, Germany
- Department of Internal Medicine, Innsbruck Medical University, Innsbruck, Austria
- Department of Gynecology and Obstetrics, Innsbruck Medical University, Innsbruck, Austria
- Department of Neurology, Innsbruck Medical University, Innsbruck, Austria

Core Facilities

- Metabolomics



Clinical Research Units

Visceral, Transplant and Thoracic Surgery



Director:
**Univ.-Prof. Dr. Dietmar
Öfner-Velano, MAS, MSc, F.A.C.S.**

Contact:
Anichstraße 35
6020 Innsbruck

Dietmar.Oefner@i-med.ac.at
Phone: +43 512 504 22600
Fax: +43 512 504 22602
www.chirurgie-innsbruck.at



**Head of Daniel Swarovski Research
Laboratory:**
Univ.-Prof. Dr. Jakob Troppmair

Contact:
Innrain 66/6th floor
6020 Innsbruck

Jakob.Troppmair@i-med.ac.at
Phone: +43 512 504 27819
Fax: +43 512 504 24625
www.i-med.ac.at/tx-research

Research Branch (ÖSTAT Classification)

301306, 301902, 301904,
302056, 302083

Keywords

Metastatic surgery, ischemia-reperfusion injury, sepsis, transplantation biology, molecular oncology, intracellular signalling, mitochondria, reactive oxygen species (ROS), translational research

Research Focus

Oncology - Metastatic Disease

- Clinical studies on surgical oncology including both retrospective single centre studies and prospective international studies, according to the affected organs
- Clinical and experimental studies on peritoneal carcinomatosis and metastatic disease

Ischemia-Reperfusion Injury in Organ Transplantation

One main focus of our research is to gain a better understanding of the pathophysiological mechanisms underlying ischemia-reperfusion (I/R) injury. I/R injury represents a threat to which all transplanted organs are subjected in the process of transplantation and which is known to crucially influence graft and patient long-term survival. Identification of the mechanisms involved would not only help to better understand this process but also to identify new treatment targets.

Sepsis

Treatment of abdominal sepsis with open abdomen treatment and negative pressure.

Daniel Swarovski Research Laboratory

Research within the DSL complements state of the art clinical work with basic and translational scientific projects in the areas of transplantation biology, molecular oncology and wound healing/tissue regeneration. Common to all of them is the involvement of intracellular signalling pathways, reactive oxygen species (ROS) and the mitochondria in the development of these pathological conditions but also as possible targets for therapeutic intervention.

General Facts

The Department of Visceral, Transplant and Thoracic Surgery maintains not only an internationally-established high volume transplant program with transplantation of all solid organs (kidney, liver, pancreas, small bowel, cluster and, in cooperation with the Department of Cardiac Surgery, heart and lung), as well as vascularised composite allografts, but also covers as a Central Hospital with tertiary patient care the entire field of general, visceral and thoracic surgery in adults and children. Translational research takes place at the Department of Visceral, Transplant, and Thoracic Surgery with its associated Daniel Swarovski Research Laboratory. Work is proceeding along three main axes, which cover the fields of main interest in transplantation, surgical oncology and infectiology, namely ischemia-reperfusion injury, sepsis and



Fig. 1: Gastric cancer with peritoneal carcinomatosis

metastatic disease. In parallel to patient care with an extended quality assurance program and risk management, the Daniel Swarovski Research Laboratory (DSL) represents a high-end research unit which creates a perfect symbiosis between clinicians and basic scientists. In a “bed to bench and back” approach: complex treatment regimens and clinical trials can be further enhanced by molecular in-depth analysis. Furthermore, the research line is supplemented by the development of proof of concept trials employing a large variety of micro-surgically most-challenging organ and limb transplantation models in small as well as large animals. Together with Prof. Jakob Troppmair as head of the DSL research laboratory, senior staff surgeons and/or senior surgical residents investigate infectious, oncological and transplantation-related topics in cell culture, small animal models and specimens from clinical trials in collaboration with regional and international research colleagues. Within a project, group leaders usually mentor diploma students, who get the unique opportunity to develop not only basic science but also (micro)surgical skills.

Research

Research Focus Oncology - Metastatic Disease

Leader: Ass.-Prof. Priv.-Doz. Dr. Alexander Perathoner, Ass.-Prof. Priv.-Doz. Dr. Florian Augustin, Dr. Pamela Kogler

Oncological science is one of the most important and dynamic areas of surgical science. The Department of Visceral, Transplant and Thoracic Surgery is able to offer complete surgical management of the whole spectrum of surgical malignancies from very frequent tumours such as colon cancer to very rare tumours such as peritoneal malignancies. Therefore, oncological research at the Department of Visceral, Transplant and Thoracic Surgery is also characterised by a broad field of variegated research topics according to the different affected organs (e.g. thyroid cancer, gastric cancer, lung cancer). Surgical science is typically dominated by clinical research: all patients with a malignant disease are registered in databases (e.g. Austrian HIPEC Registry) to allow periodic retrospective and prospective analyses. The ongoing surveillance of oncological patients also enables the Department to participate in important national (e.g. ABCSG 16/SALSA Study and ABCSG 26/SOLE Study on extended endocrine therapy in breast cancer patients) and international studies

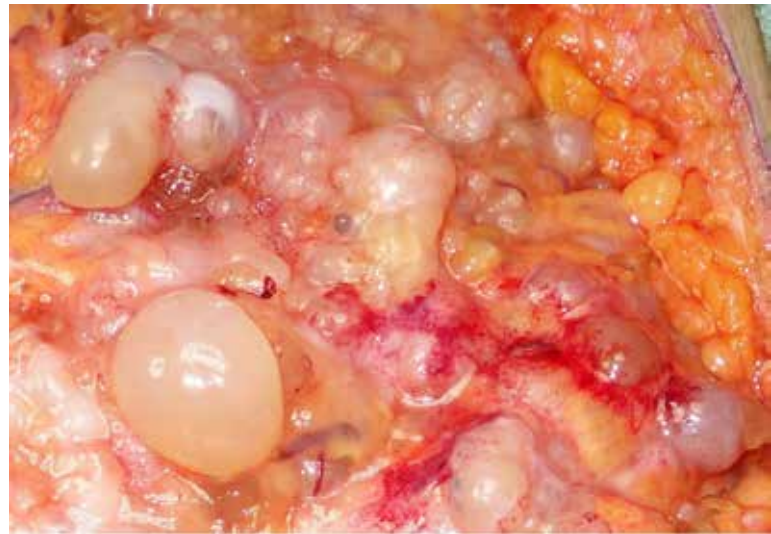

Fig. 2: Mucinous neoplasia of the peritoneum (*Pseudomyxoma peritonei*)

(e.g. international multicentre study on surgical morbidity in lung cancer patients with VATS-lobectomy).

The clinical research includes diagnostic tools (e.g. the diagnostic value of ultrasound in thyroid cancer) as well as new treatment options (e.g. hyperthermic intraperitoneal chemotherapy in patients with peritoneal carcinomatosis). Of course, experimental projects also play a very important role in oncological research at the Department of Visceral, Transplant and Thoracic Surgery: scientists in our own laboratories or in cooperating laboratories work on various projects, including studies on transcription factors (e.g. STAT-1 in gastric cancer and colorectal cancer), adhesion molecules (e.g. CD44v6 in patients with non-small cell lung cancer), cytokines (e.g. in peritoneal carcinomatosis) and numerous other proteins (e.g. lipocalin 2 in colon cancer patients).

Given that the treatment of patients with metastatic disease has changed significantly in the last years due to the development of multimodal therapies, the Department of Visceral, Transplant and Thoracic Surgery intends to establish this topic as a new focus in surgical oncological science. The aim of the Metastasis Research Group in the future will be to combine clinical and experimental scientific projects in order to improve understanding of metastatic disease and treatment of patients with metastases. The following list of different exemplary clinical and experimental studies displays the broad spectrum of oncological research at the Department of Visceral, Transplant and Thoracic Surgery according to the pri-

mary affected organs:

ABCSG Study 16/SALSA: Prospective, randomised, open-label, multi-centre, phase-II-study evaluating the effect of a secondary adjuvant endocrine therapy with anastrozole for 2 years vs. 5 years in patients with hormone-receptor-positive breast cancer after 5 years prior adjuvant endocrine therapy. (Research Group Breast Cancer)

Study on volatile organic compounds in non-small cell lung cancer tumour tissue, aiming to define tumour markers for monitoring of therapy and for early detection of recurrent disease. (Research Group Lung Cancer)

LM-02 Trial: A perioperative, single-arm, multicentre, phase-II academic trial to investigate the efficacy and safety of panitumumab in combination with irinotecan/5-fluorouracil/leucovorin (FOLFIRI) in patients with previously untreated, RAS-wild-type, potentially resectable colorectal cancer liver metastases. (Research Group Colorectal Cancer)

ASAMET Trial: A randomised, phase II, double-blind, placebo-controlled, multicentre, 2x2 factorial design biomarker tertiary prevention trial of low dose aspirin and metformin in stage I-III colorectal cancer patients. (Research Group Colorectal Cancer)

Single centre prospective analysis of cancer-associated cytokines in serum and peritoneal fluid of patients undergoing cytoreductive surgery (CRS) and hyperthermic intraperitoneal chemotherapy (HIPEC) for peritoneal surface malignancies as a potential tool for perioperative therapy moni-

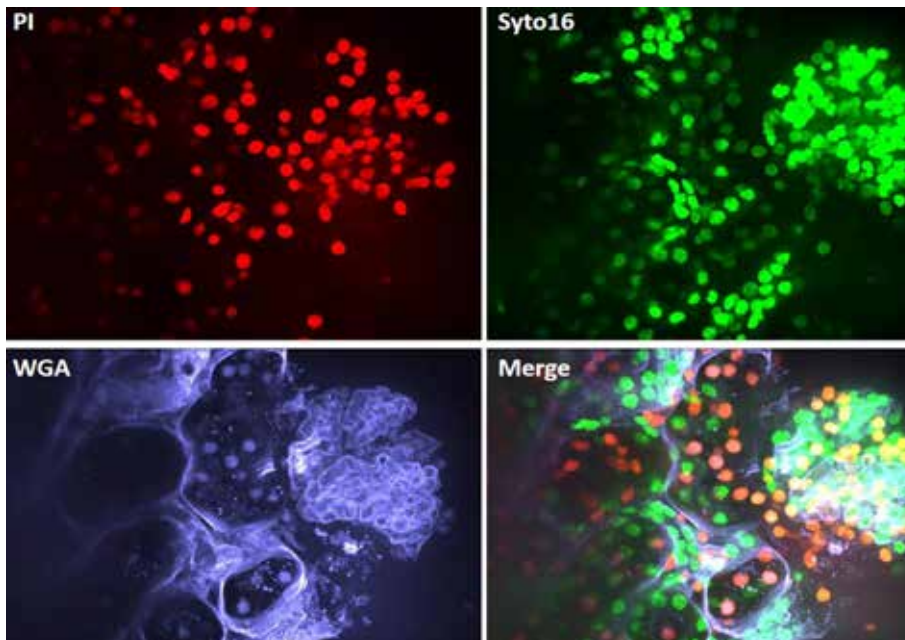

Fig. 3: Real-time live confocal imaging of the cortical region of a glomerulus of a kidney. Following left renal ischemia and reperfusion fine needle biopsies of murine kidneys were taken and incubated with the live stains Syto 16 (green), propidium iodide (PI; red) and wheat germ agglutinin (WGA, blue), thereby staining all the nuclei, the nuclei of the dead cells and the tissue morphology. Images were acquired with a 40x water immersion objective. One representative example is shown consisting of a z-stack of 25 planes with a spacing of 1 μ m.

toring. (Research Group Peritoneal Carcinomatosis)

Research Focus Ischemia-Reperfusion Injury

Leader: ao. Univ.-Prof. Dr. Stefan Schneeberger, Assoz.-Prof. Priv.-Doz. Dr. Manuel Maglione, Ass.-Prof. Dr. Rupert Oberhuber

Solid organ transplantation has become the routine therapy for end-stage organ failure and advancements in surgery, preservation techniques, immunosuppressive and anti-infection therapy have helped to reach a 90% graft survival rate in liver, kidney and pancreas transplantation.

Currently, not only organ shortage and late allograft loss but also the complex and consuming logistics represent remaining major hurdles to further enhancing the success of solid organ transplantation. Limiting ischemia/reperfusion (I/R) injury may help to increase the organ pool, limit short and long term graft damage and ease the burden of the emergency of the transplant procedure. Hence the focus of both clinical and experimental research efforts at our institution is to gain a better understanding and to find a way to prevent and ameliorate I/R injury. Clinical trials and in vitro studies are accompanied by rodent models for organ

transplantation. The assessment of tissue damage is performed by morphological analysis including live confocal fluorescence microscopy, histopathology and immunohistochemistry, electron microscopy, and biomolecular methods including western blots, enzyme activity assays, RTqPCR, proteomics and gene chip analysis.

While the phenotype of I/R injury has been quite well established in solid organ transplantation, no such detailed analysis is available for transplantation of vascularised composite tissue allografts such as the hand or the face. While this field is relatively new, in the past 15 years vascularised composite tissue allotransplantation (VCA) has become a rapidly advancing field with more than 100 hand/forearm transplantations and 20 face transplantations carried out in transplant centres all over the world. We have recently established the first in-depth analysis of the tissue damage induced by I/R injury in rodent models. Employing electron microscopy, confocal microscopy and molecular analysis of tissue-infiltrating inflammatory cells and markers for tissue damage, we have identified the injury to individual tissues as well as the architecture of the graft. Furthermore, we have tested established as well as novel preservation

solutions for their effect on preventing I/R injury on individual tissues of a vascularised composite isograft. In summary, limiting cold ischemia time below 6 hours was observed to be the most significant factor to reduce tissue damage in VCA. Our data indicate that preservation solutions in general seem to have little impact to avoid tissue damage in a vascularised composite allograft. Interestingly, histomorphologic signs of regeneration were also observed in skeletal muscle, the tissue being affected most of all in a vascularised composite graft. These observations give rise that ischemic tissue (muscle) damage in VCA might be reversible to a certain extent. However, novel strategies to attenuate IR injury in VCA are urgently needed.

In this context, the analysis of the immunomodulatory properties of tetrahydrobiopterin, a naturally occurring potent antioxidative agent structurally related to the vitamin's folate and riboflavin is entertained in a dedicated research track. In addition to its antioxidative properties, tetrahydrobiopterin is also known as an essential co-factor for a set of 8 different enzymes, including the three nitric oxide synthase (NOS) isoforms (neuronal, endothelial, and inducible). We could show in a pancreas transplantation model in mice that treating the donor with exogenous tetrahydrobiopterin could effectively prevent lethal I/R injury in the transplanted recipient [1,2].

In a clinically more relevant model, the same treatment regimen was also able to prevent lethal I/R injury in a brain death mouse model. Recently, we could demonstrate in an aortic transplantation model the crucial role of severe I/R injury in inducing transplant vasculopathy and the role of tetrahydrobiopterin in preventing it. The two constitutive nitric oxide synthase isoforms (endothelial and neuronal) were identified as the target for tetrahydrobiopterin treatment in the prevention of both I/R injury and the subsequent transplant vasculopathy. Based on the observation that tetrahydrobiopterin prevents acute rejection in a heart transplantation model independently of nitric oxide synthase activity, the focus of future studies will also be on a possible immunomodulatory role of other tetrahydrobiopterin-dependent enzymes. Current projects in this field focus on (1) simvastatin, which is hypothesised to prevent I/R injury and transplant vasculopathy by a tetrahydrobiopterin-mediated process, and on the immunomodulatory role of the

tetrahydrobiopterin-dependent enzyme tryptophan hydroxylase (TPH-1).

1. Cardini B, Watschinger K, Hermann M, Obrist P, Oberhuber R, Brandacher G, et al. Crucial Role for Neuronal Nitric Oxide Synthase in Early Microcirculatory Derangement and Recipient Survival following Murine Pancreas Transplantation. *PLoS One*. 2014;9(11):e112570. doi: 10.1371/journal.pone.0112570. PubMed PMID: 25389974; PubMed Central PMCID: PMC4229216.

2. Prevention of lethal murine pancreas ischemia reperfusion injury is specific for tetrahydrobiopterin. Maglione M, Cardini B, Oberhuber R, Watschinger K, Jenny M, Gostner J, et al. *Transpl Int*. 2012;25(10):1084-95. doi: 10.1111/j.1432-2277.2012.01530.x. PubMed PMID: 22805419.

3. Treatment with tetrahydrobiopterin overcomes brain death-associated injury in a murine model of pancreas transplantation Oberhuber R, Ritschl P, Fabritius C, Nguyen AV, Hermann M, Obrist P, Werner ER, Maglione M, Flörchinger B, Ebner S, Resch T, Pratschke J, Kotsch K. *Am J Transplant*. 2015 Nov;15(11):2865-76. doi: 10.1111/ajt.13364

4. Oberhuber R, Riede G, Cardini B, Bernhard D, Messner B, Watschinger K, et al. Impaired Endothelial Nitric Oxide Synthase Homodimer Formation Triggers Development of Transplant Vasculopathy - Insights from a Murine Aortic Transplantation Model. Oberhuber R, Riede G, Cardini B, Bernhard D, Messner B, Watschinger K, et al. *Sci Rep*. 2016;6:37917. Epub 2016/11/24. doi: 10.1038/srep37917. PubMed PMID: 27883078; PubMed Central PMCID: PMC45121662.

5. Brandacher G, Maglione M, Schneeberger S, Obrist P, Thoeni G, Wrulich OA, et al. Tetrahydrobiopterin compounds prolong allograft survival independently of their effect on nitric oxide synthase activity. *Transplantation*. 2006;81(4):583-9. PubMed PMID: 4.

In order to address the suitability of organs for transplantation from older donors and extended criteria donors (ECD) assessment of kidney and liver graft cell viability and inflammation during organ preservation is to have prognostic value in addition and beyond the established clinical parameters. Expression of cytokines, e.g. (CXCL-1, tu-

mor necrosis factor- α , interleukin [IL]-1 β , IL-6, IL-10, IFN γ , IL-4, IL-2, Rantes (CCL5), Mip1a (CCL3), IP10 (CXCL-10), TGF β , MCP1(CCL2)) is performed employing real-time polymerase chain reaction (PCR). All nuclei are stained with Syto 16. To discriminate between live and dead cells propidium iodide (PI) staining. In order to visualise tissue morphology wheat germ agglutinin (WGA) will be added as a third stain. Cytokine expression and confocal microscopy readouts may eventually help to the true quality and suitability of organs for transplantation.

Our aim is to establish a rapid assessment tool of donor liver quality and investigate its predictive value for the clinical use. Based on our experimental data we propose a prospective clinical trial combining live confocal real-time analysis, cytokine expression profiling, as a new clinical tool for the assessment of graft quality in deceased donor liver transplantation.

In summary, significant progress in the immediate diagnosis of organ quality and I/R injury has been achieved and is currently implemented in clinical trials. Since the technological innovation of machine perfusion is being introduced at our centre, further and significant advancements can be expected. This development, combined with the prospect to develop a meaningful prophylaxis and treatment of I/R injury may result in significant amelioration of organ damage in the process of transplantation but also allow for significant prolongation of organ preservation, thereby lifting the burden of high-urgency surgical procedures.

Research Focus Sepsis

Leader: Priv.-Doz. Dr. Reinhold Kafka-Ritsch
The research on abdominal sepsis is integrated into the clinical routine of the department; the main focus is on the development of new strategies for the treatment of abdominal sepsis. The ongoing prospective randomised study is administered by our study coordination office.

Abdominal sepsis with generalised peritonitis is a life-threatening condition requiring immediate surgical intervention. Despite intervention, a high percentage of these patients develop severe septic shock with multi-organ dysfunction. At the time of emergency laparotomy, patient recovery is uncertain and stabilisation of the patient in the intensive care unit is recommended. We have developed a damage control concept using abdominal vacuum therapy to treat patients' abdominal sepsis. The primary aim

of this concept is to enhance recovery and allow bowel reconstruction in a second-look operation.

At present we are performing a prospective randomised study on the surgical treatment of patients with colonic perforation and peritonitis, treating with a damage control strategy and application of abdominal vacuum therapy.

In collaboration with the World society of emergency surgery (WSES) indication and strategies for open abdomen treatment with negative pressure in abdominal sepsis and a strategy for optimal antimicrobial therapy were elaborated and published:

- Antimicrobials: a global alliance for optimising their rational use in intra-abdominal infections (AGORA). Sartelli M et al. *World J Emerg Surg*. (2016)
- The role of the open abdomen procedure in managing severe abdominal sepsis: WSES position paper. Sartelli M et al. *World J Emerg Surg*. (2015)

As ERAS concepts have changed in favour of preoperative bowel preparation and oral antibiotics, a new focus will be addressed on the feasibility and side effects of bowel preparation and preoperative oral antibiotics, e.g. selection of resistant bacteria, change in the microbial flora, the microbiome and postoperative intestinal function.

Daniel Swarovski Research Laboratory

The Daniel Swarovski Research Laboratory (DSL) associated with the Department of Visceral, Transplant and Thoracic Surgery (VTT, Director: Univ.Prof. Dr. med. Dietmar Öfner-Velano) was established to add to the challenging and successful solid organ transplantation program initiated by Prof. Raimund Margreiter, an equally ambitious research focus. Both basic researchers and clinical research groups carry out scientific projects at the DSL, which provides a broad range of methodological platforms in the areas of molecular and cellular biology, imaging, immune phenotyping and small animal surgery.

Apart from the group of Jakob Troppmair, the DSL harbours groups headed by clinical fellows, in particular a.o. Univ. Prof. Dr. Stefan Schneeberger and Assoz. Prof. PD Dr. Manuel Maglione, who carry out research projects in the area of IRI and composite tissue allotransplantation (CTA) in close collaboration with the other members of the lab. Moreover, the group of a.o. Univ. Prof. Dr. Erich Gnaiger focuses on the develop-

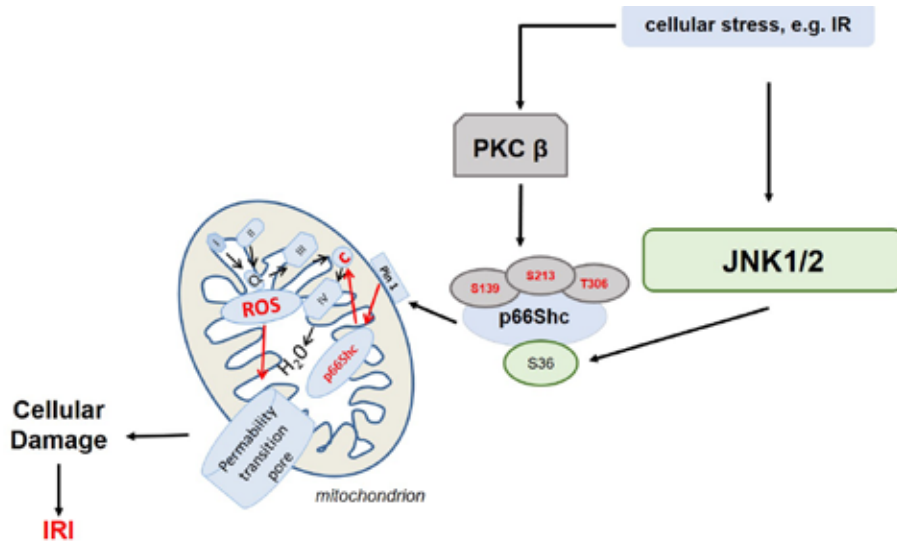

Fig. 3: Scheme of pathways regulating p66Shc activation based on our recent findings. Our data also suggest that phosphorylation of S36 by JNK1/2 primes p66Shc for subsequent phosphorylation by PKCβ

ment and implementation of methods for the high-resolution respirometry and is an important collaboration partner in many national and international research projects.

Preventing ischemia-reperfusion injury (IRI)

Cessation of blood flow during the transplantation of solid organs (ischemia) and subsequent reperfusion are potent triggers for the impairment of organ function. Paradoxically it is the burst in the production of reactive oxygen species (ROS) during early reperfusion, which triggers inflammatory processes and the activation of the innate immune system and thus is most critical for the development of IRI. Clinically, antioxidants have proven inefficient in the prevention or treatment of IRI. To this end, we have begun to study means to control excessive ROS production during early reperfusion. We initially identified signalling pathways activated at the earliest time points during reperfusion and then addressed their contribution to the development of IRI with a particular focus on ROS production, using in vitro and in vivo (organ clamping, organ transplantation in rodents) approaches. Another important question relates to the source of ROS.

In the past, mitochondrial and non-mitochondrial sources (in particular NADPH-dependent oxidases, NOX) have been implicated, mainly through genetic studies, in the development of IRI. To this end, we have begun to focus our research on the ox-

idoreductase p66Shc. p66Shc ablation has been shown to prevent many disease conditions linked to oxidative stress, including IRI, while not negatively affecting normal development or postnatal life. p66Shc is normally located in the cytoplasm and activation is thought to require phosphorylation on serine 36 by PKCβ, which is essential for mitochondrial import and oxidation of cytochrome c resulting in the production of H₂O₂. Our initial experiments suggested that phosphorylation regulation of p66Shc activation is far more complex and that PKCβ is not the kinase involved in S36 phosphorylation. A particular focus was on mitogen-activated protein kinases (MAPKs). This group of kinases gets activated during early reperfusion and we have already shown previously that signalling through RAF-MEK-ERK prevented excessive ROS production, mitochondrial Ca²⁺ overload and cell death. A pro-oxidant function we could demonstrate for signalling through p38-MK2. Since no inhibitors of p66Shc are currently available, we reasoned that understanding the complex regulation of p66Shc activation will provide targets for therapeutic interference with the development of oxidative damage.

Preventing malignant Transformation by oncogenic BRAF

Recent decades have seen a rapid development in the understanding of the genetic alterations contributing to tumour formation and of the pathways and processes regulated by them. Many oncogenes and tumour

suppressor genes have been identified and catalytically active compounds have been targeted by small molecular weight compounds. Success has been varying and development of resistance continues to be a problem. Alternative target are currently sought in the metabolic alterations, which allow tumour cells to adapt to increasing and changing needs. Driving forces behind the metabolic switch are changes in the tumour microenvironment, oncogenic signalling pathways and mutations affecting intrinsic compounds of metabolic pathways. Less researched are changes in the production of ROS, which usually appears to be increased in tumours, while there may also be exemptions, e.g. melanoma. Conceptually, the current understanding is that despite the high ROS phenotype of tumours, they still are exquisitely sensitive to a further increase of ROS, which is triggered by many drugs used in cancer treatment, for example. Also, lowering ROS levels in tumours may negatively affect tumour survival. Our ongoing research aims at understanding how oncogenic signalling pathways regulate ROS levels in tumours and how this knowledge may be exploited to design therapeutic approaches for the modulation of intracellular ROS levels to induce tumour cell death. The focus is on mechanisms, which we also study in the setting of IRI. In particular, p66Shc is overexpressed in many tumors and has been shown to be necessary for the drug-induced killing of prostate cancer cells.

Regulation of Tumour Growth by Protein-Protein interactions

Cell signalling pathways comprise of additional proteins as well as the core signalling molecules, which are essential for proper signal propagation and signal delivery. In the search for alternative approaches to overcome treatment resistance to kinase inhibitors, targeting the interaction of signalling proteins with their scaffold proteins, for example, may provide novel therapeutic approaches. In our work we are targeting the interaction of RAF kinases with the proteins RKIP and BAG-1. RKIP may negatively interfere with the signal propagation from RAF kinases to their downstream target MEK1/2. Not surprisingly therefore RKIP is frequently lost in tumours. In a longstanding collaboration with Assoz.-Prof. Priv.-Doz. Dr. Armin Zebisch and Univ. Prof. Dr. Heinz Sill from the Medical University of Graz, we have begun to analyse the contribution of RKIP to malignant transformation and have recently addressed the role of miRNAs in the regulation of RKIP expression. We have

previously identified BAG-1 as the binding partner of RAF kinases, which may be involved in cell survival.

Recent Major Achievements

Identification of signalling pathways regulating p66Shc activation: In our work, we identified key phosphorylation steps and kinases involved in the activation of p66Shc providing the basis for future therapeutic testing in animal models. PKC β had already been implicated in the phosphorylation of serine 36 on p66Shc, which is necessary for mitochondrial import and pro-oxidant function. Re-evaluation of these findings could confirm the requirement for PKC β but not for the phosphorylation of S36. In our work, we identified the kinases responsible for S36 phosphorylation and mapped the sites targeted by PKC β . Use of these sites for the regulation of p66Shc activation was confirmed by genetic means and MS.

Regulation of oncogenic RAF signaling by interacting proteins: RKIP has been positioned between RAF and MEK and RKIP loss, which is frequently observed in tumours and may contribute to the hyper-activation of ERK1/2. The reasons for RKIP loss are largely unknown. In recent collaborative work, we have identified miR-23a as a negative regulator of RKIP expression in AML and have provided data that suggest the importance of this observation beyond this tumour entity.

Selected Publications

Impaired Endothelial Nitric Oxide Synthase Homodimer Formation Triggers Development of Transplant Vasculopathy - Insights from a Murine Aortic Transplantation Model

Oberhuber, Rupert, Riede, Gregor, Cardini, Benno, Bernhard, David, Messner, Barbara, Watschinger, Katrin, Steger, Christina, Brandacher, Gerald, Pratschke, Johann, Golderer, Georg, Werner, Ernst R., Maglione, Manuel, SCIENTIFIC REPORTS: 2016; 6: S. 37917

cJUN N-terminal kinase (JNK) phosphorylation of serine 36 is critical for p66Shc activation

Khalid, Sana, Drasche, Astrid, Thurner, Marco, Hermann, Martin, Ashraf, Muhammad Imtiaz, Fresser, Friedrich, Baier, Gottfried, Kremser, Leopold, Lindner, Herbert, Troppmair, Jakob, SCIENTIFIC REPORTS: 2016; 6: S. 20930

Treatment With Tetrahydrobiopterin Overcomes Brain Death-Associated Injury in a Murine Model of Pancreas Transplantation

Oberhuber, R., Ritschl, P., Fabritius, C., Nguyen, A. -V., Hermann, M., Obrist, P., Werner, E. R., Maglione, M., Floerchinger, B., Ebner, S., Resch, T., Pratschke, J., Kotsch, K., AMERICAN JOURNAL OF TRANSPLANTATION: 2015; 15: S. 2865-2876

CD11c(+) Dendritic Cells Accelerate the Rejection of Older Cardiac Transplants via Interleukin-17A

Oberhuber, Rupert, Heinbokel, Timm, Biefer, Hector Rodriguez Cetina, Boenisch, Olaf, Hock, Karin, Bronson, Roderick T., Wilhelm, Markus J., Iwakura, Yoichiro, Edtinger, Karoline, Uehara, Hirofumi, Quante, Markus, Voskuil, Floris, Krenzien, Felix, Slegtenhorst, Bendix, Abdi, Reza, Pratschke, Johann, Elkhali, Abdallah, Tullius, Stefan G., CIRCULATION: 2015; 132: S. 122-131

Receptor for hyaluronic acid-mediated motility (RHAMM, CD168) expression is prognostically important in both nodal negative and nodal positive large cell lung cancer

Augustin, Florian, Fiegl, Michael, Schmid, Thomas, Pomme, Geoffrey, Sterlacci, William, Tzankov, Alexander, JOURNAL OF CLINICAL PATHOLOGY: 2015; 68: S. 368-373

The role of lipocalin-2 in liver regeneration

Kienzl-Wagner, Katrin, Moschen, Alexander R., Geiger, Sabine, Bichler, Alexandra, Aigner, Felix, Brandacher, Gerald, Pratschke, Johann, Tilg, Herbert, LIVER INTERNATIONAL: 2015; 35: S. 1195-1202

Novel Insights into the PKC-dependent Regulation of the Oxidoreductase p66Shc

Haller, Martina, Khalid, Sana, Kremser, Leopold, Fresser, Friedrich, Furlan, Tobias, Hermann, Martin, Guenther, Julia, Drasche, Astrid, Leitges, Michael, Giorgio, Marco, Baier, Gottfried, Lindner, Herbert, Troppmair, Jakob, JOURNAL OF BIOLOGICAL CHEMISTRY: 2016; 291: S. 23557-23568

Increased Expression of miR-23a Mediates a Loss of Expression in the RAF Kinase Inhibitor Protein RKIP

Hatzl, Stefan, Geiger, Olivia, Kuepper, Maja Kim, Caraffini, Veronica, Seime, Till, Furlan, Tobias, Nussbaumer, Erika, Wieser, Rotraud, Pichler, Martin, Scheideler, Marcel, Nowek, Katarzyna, Jongen-Lavrencic, Mojca, Quehenberger, Franz, Woelfler, Albert, Troppmair, Jakob, Sill, Heinz, Zebisch, Armin, CANCER RESEARCH: 2016; 76: S. 3644-3654

A combination of trastuzumab and BAG-1 inhibition synergistically targets HER2 positive breast cancer cells

Papadakis, Emmanouil, Robson, Natalia, Yeomans, Alison, Bailey, Sarah, Laversin, Stephanie, Beers, Stephen, Sayan, A., Ashton-Key, Margaret, Schwaiger, Stefan, Stuppner, Hermann, Troppmair, Jakob, Packham, Graham, Cutress, Ramsey, ONCOTARGET: 2016; 7: S. 18851-18864

Selected Funding

- DK Molecular Cell Biology and Oncology (MCBO), FWF W1101

Collaborations

- Peter J. Friend, Rutger Ploegh, University of Oxford, Nuffield Department of Surgical Sciences, Oxford, UK
- Keith M., Channon University of Oxford, Division of Cardiovascular Medicine, Radcliffe Department of Medicine, Wellcome Trust Centre for Human Genetics, Oxford, UK
- Darius Mirza, University Hospitals Birmingham, Liver and Hepato-Pancreato-Biliary (HPB) Unit, Birmingham, UK
- Gerald Brandacher, Andrew WP Lee, Johns Hopkins Medical University, Department of Plastic Surgery, Baltimore, USA
- University of Pittsburgh Medical Center (UPMC), Division of Plastic and Reconstructive Surgery, Department of Surgery, Pittsburgh, USA
- Hans Schlitt, Universitätsklinikum Regensburg, Klinik und Poliklinik für Chirurgie, Regensburg, GER
- Kurt Werner Schmid, Universitätsklinikum Essen, Institut für Pathologie, Essen, GER
- Emmanuel Morelon, Hospices Civils de Lyon, Hospital Edouard Herriot - Transplantation, néphrologie et immunologie, Lyon, FR
- Emmanouil S. Papadakis, Graham Packham, Ramsey Cutress, Cancer Research UK Centre, Cancer Sciences Division, University of Southampton Faculty of Medicine, Southampton General Hospital, Southampton, United Kingdom
- Andrew Cato, Karlsruhe Institute of Technology, Institute of Photon and Synchrotron Radiation, Eggenstein-Leopoldsdshafen, Germany
- Armin Zebisch, Heinz Sill, Division of Hematology, Medical University of Graz, Graz, Austria
- Stefan Wiese, Faculty for Biology and Biotechnology, Group for Molecular Cell Biology, Ruhr University Bochum, Bochum, Germany
- Eduard Stefan, Institute of Biochemistry and Center for Molecular Biosciences, University of Innsbruck, Innsbruck, Austria

Cardiac Surgery



Director:
Univ.-Prof. Dr. Michael Grimm

Contact:
Anichstraße 35
6020 Innsbruck

Michael.Grimm@i-med.ac.at
Phone: +43 512 504 22501
Fax: +43 512 504 22502
www.i-med.ac.at/carelab

Research Branch (ÖSTAT Classifications)

304007, 302048, 302083,
302018, 302026

Keywords

Myocardial infarction, heart valve disease, angiogenesis, shockwave therapy, gene therapy

Research Focus

The aim of the cardiosurgical research laboratory is to perform highest quality experimental research with a clear focus on translational aspects. Our projects shall broaden the knowledge in pathophysiology of the heart in order to develop new treatment strategies. Such new treatments are investigated in the experimental setting in animal models and cell cultures - not for publication only, but with the clear intention to establish newly developed techniques in the clinical setting for the benefit of our cardiosurgical patients

General Facts

The University Clinic of cardiac surgery acts as a modern cardiosurgical unit with

focus on surgical outcome, quality control, and development of modern cardiosurgical strategies combined with patient well-being and advanced training of surgeons and surgical staff.

The research strategy of the University Clinic for Cardiac Surgery is split into two main concepts and generally covers central aspects of cardiovascular surgery, medicine, and biology. With application-oriented projects we seek i) to improve myocardial protection and regeneration after infarction, ii) to understand the pathophysiology of heart valve disease, and iii) to develop new tests allowing for the early diagnosis of and screening for thoracic aortic aneurysms in blood samples. Several of these studies are done in cooperation with companies. With basic science projects we seek to define fundamental molecular and cellular pathophysiological processes leading to cardiovascular diseases, allowing for a later application in diagnosis, prevention and treatment of patients. Techniques cover areas of analytical chemistry, molecular and cellular biology, primary human cell culture, tissue and organ culture studies, as well as patient-based studies.

Research

Myocardial Regeneration by Shockwave Therapy

The main aim of our research in this field is to regenerate infarcted myocardium, respectively the hibernating myocardium. We use LAD ligation models—chronic, acute and ischemia/reperfusion—in different species. Besides regeneration we work on the induction of angiogenesis as well as vasculogenesis.

In addition to our *in-vivo* models we use several *in-vitro* assays, such as the transwell migration assay and as an *ex-vivo* model the aortic ring assay.

Shockwaves are sound-pressure waves that occur in nature whenever there is a sudden release of energy, e.g. as thunder when lightning. In medicine they are used for more than 30 years in lithotripsy to disintegrate kidney stones.

More recently they were found to have regenerative effects at low energy levels. Therefore shockwaves are already routinely used in orthopaedics and traumatology for tendon pathologies, bone non-unions or wound healing disturbances. Without harming cells or causing any other damage, low

energy shockwaves modulate inflammation and thereby create the environment for regeneration. In ischemic myocardium this mainly means neovascularization (new blood vessel formation). Both, angiogenesis (sprouting of existing vessels) as well as vasculogenesis (*de novo* vessel formation by recruitment of endothelial progenitor cells) can be found.

During the last years we developed shockwave therapy for application directly to the myocardium and have been able to show promising results by means of functional heart improvement. Our current research aims to fully elucidate the working mechanism in order to support broad clinical use of shockwave therapy for patients suffering from myocardial infarction.

Innate Immunity Toll-like receptors (TLR) represent a highly conserved part of the innate immune system. They have been described to play numerous roles in physiological and pathological mechanisms. TLR3 and TLR4 closely interact with each other as they share a common signalling pathway via TRIF (TIR-domain-containing adapter-inducing interferon- β). Our aim is to elucidate the role of these two receptors in the heart. Toll-like receptor 3 binds double-stranded RNA or nucleic acids in general, being thereby responsible to recognize viral infections. TLR4 usually detects lipopolysaccharides from Gram-negative bacteria. Recently, we found that TLR3 signalling induces regeneration to myocardium as well as acting protective in spinal cord ischemia. In parallel to this effect, TLR4 gets down-regulated.

Discovering the Pathophysiology of Heart Valve Calcification

Calcific aortic valve is the most prevalent heart valve pathology in the developed

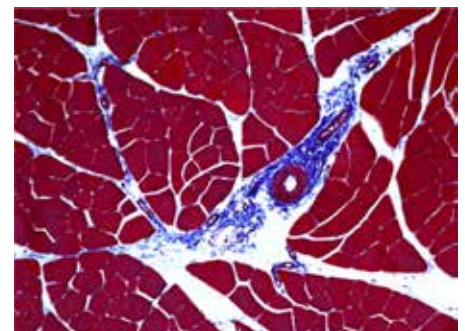

Fig 1: Angiogenesis - vessel sprouting within the heart muscle in an ischemic border zone induced by direct cardiac shockwave therapy in a mouse LAD ligation model.

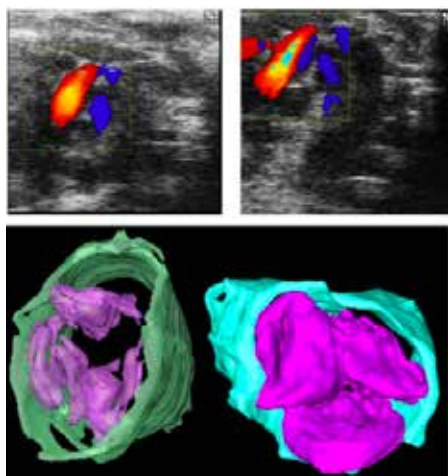

Fig. 2: Echocardiography with the Visualsonics Vevo 1100 (corefacility) of mouse aortic valves (upper pictures) and 3D modeling of aortic valve leaflets from microCT pictures.

world and is concomitant with devastating consequences. A progressive stenosis of the aortic orifice impedes regular blood flow during systole causing increased workload for the left ventricle. Progression of the disease can result in heart failure. The pathology starts as aortic valve sclerosis, a state in which the leaflets are thickened without significant stenosis.

This stage precedes aortic valve stenosis, where measurable obstruction of the outflow tract and significant gradients above are observed. Described risk factors for calcific aortic valve disease include older age, male sex, hypertension, smoking, hypercholesterolemia and diabetes.

On a cellular level it has been shown that valvular interstitial cells, the predominant cell type in heart valves, can switch to an osteoblastic phenotype upon triggers like inflammation, oxidative stress, renin-angiotensin signalling and cause progressive calcification. In a healthy valve, this cell type is responsible for maintain the homeostasis of the valve. However, it is poorly understood which factors contribute to the phenotype switch of valvular interstitial cells. Better knowledge of the calcification process could reveal new targets for the detection of early stage valve disease and for therapeutic intervention. Our group aims to identify novel pathomechanisms of calcific aortic valve disease. We therefore established numerous *in vitro* models using cells isolated from human aortic valves obtained from cardio-surgical patients to mimic calcification. In addition, we have established various murine *in vivo* models of valve disease.

Thereby, we analyze the role of biomechanics in the development of aortic valve disease. Biomechanical strain and stress were shown to play a major role in the development of calcific aortic valve disease, as the disease starts where the mechanical strain is highest. Patients who show increased strain upon the aortic valve due to bicuspid valves or hypertension have a significantly higher risk for the development of calcific aortic valve disease.

However, it remains unknown how the mechanical stimulus is translated into a pro-calcific response. In addition, our lab works aims to elucidate the interaction between innate immunity and calcific aortic valve disease. It is becoming more and more evident that the innate immune system and its pattern recognition receptors play a major role in the pathogenesis of various cardiovascular pathologies. However, its role in the development and progression of calcific aortic valve disease remains largely unknown.

Discovering the Pathophysiology of Aortic Aneurysm Formation

Aortic diseases include a plethora of pathologies that can affect people across all age groups. This is ranging from genetic disorders (e.g. Marfan Syndrome, congenital abnormalities) which are more commonly seen in younger individuals, to aortic aneurysms and aortic dissections, which usually affect aged patients. Depending on the severity of the disease, most of the patients suffering from this aortic pathology will need surgical repair. Moreover, aortic pathologies such as aortic dissection or traumatic aortic injury often are acute life-threatening conditions that need immediate surgical repair. Very little is known about the mechanisms that lead to the development of aortic aneurysms or dissections. Known risk factors

include smoking, hypertension and atherosclerosis. Despite this knowledge, it is very difficult to predict which patients are more likely to develop an aortic aneurysm, as formerly given risk factors are very common within a population.

Therefore, we investigate possible pathomechanisms behind aortic aneurysms and dissections in order to develop superior diagnostic tools and treatment options to further improve patient care. For this type of research we mainly use animal models from different mouse knock-out strains and collect samples from our cardio-surgical patients in order to investigate tissue and cellular aspects of the pathology.

Selected Publications

Toll-like receptor 3 signalling mediates angiogenic response upon shock wave treatment of ischaemic muscle.
Holfeld J, Tepeköylü C, Reissig C, Lobenwein D, Scheller B, Kirchmair E, Kozaryn R, Albrecht-Schgoer K, Krapf C, Zins K, Urbschat A, Zacharowski K, Grimm M, Kirchmair R, Paulus P. *CARDIOVASCULAR RESEARCH*: 2016 Feb 1;109(2):331-43. doi: 10.1093/cvr/cwv272.

Shock Wave Treatment Protects From Neuronal Degeneration via a Toll-Like Receptor 3 Dependent Mechanism: Implications of a First-Ever Causal Treatment for Ischemic Spinal Cord Injury.
Lobenwein D, Tepeköylü C, Kozaryn R, Pechriggl EJ, Bitsche M, Graber M, Fritsch H, Semsroth S, Stefanova N, Paulus P, Czerny M, Grimm M, Holfeld J. *JOURNAL OF THE AMERICAN HEART ASSOCIATION*: 2015 Oct 27;4(10):e002440. doi: 10.1161/JAHA.115.002440.

Alteration of inflammatory response by shock wave therapy leads to reduced calcification of decellularized aortic xenografts in mice.
Tepeköylü C, Lobenwein D, Blunder S, Kozaryn R, Dietl M, Ritschl P, Pechriggl EJ, Blumer MJ, Bitsche M, Schistek R, Kotsch K, Fritsch H, Grimm M, Holfeld J. *EUROPEAN JOURNAL OF CARDIOTHORACIC SURGERY*: 2015 Mar;47(3):e80-90. doi: 10.1093/ejcts/ezu428.

Core Facilities

Corefacility for small animal echocardiography - Visualsonics Vevo 1100

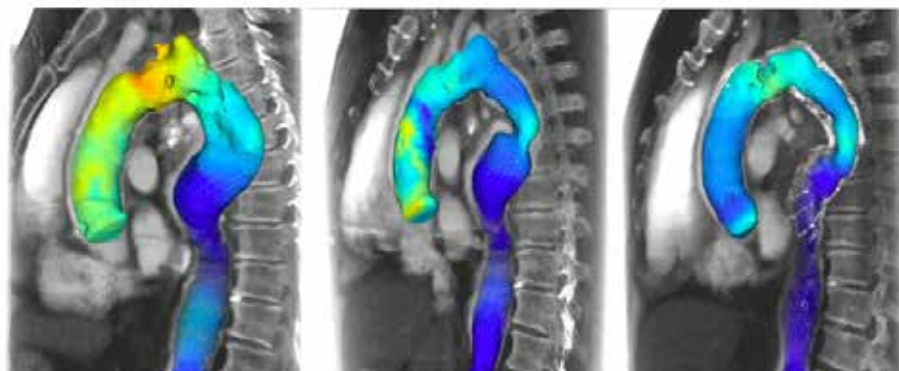

Fig. 3: The pathomechanism of aortic aneurysm formation is one of the main focus of the cardio-surgical research laboratory

Vascular Surgery



Director:
Univ.-Prof. Dr. Gustav Fraedrich

Contact:
Anichstraße 35
6020 Innsbruck

Gustav.Fraedrich@i-med.ac.at
Phone: +43 512 504 22587
Fax: +43 512 504 22559
<http://gefaesschirurgie.tirol-kliniken.at>

Research Branch (ÖSTAT Classification)

302018, 302052, 302063,
302070, 302077

Keywords

Peripheral arterial disease, cerebrovascular disease, aortic aneurysm, aortic dissection, vascular trauma, venous disease, arterial and venous thrombosis, atherosclerosis

Research Focus

- Treatment of patients with asymptomatic stenosis of the internal carotid artery (comparing the treatment techniques carotid artery stenting vs. carotid endarterectomy in the ACST-2)
- Treatment and follow up of patients with acute and chronic Type B-Dissection
- Bone marrow derived stem cells in the treatment of patients with critical limb ischemia
- Risk factor assessment in patients with peripheral arterial disease and investigation of cardiovascular complication rates in a long term follow up
- Vascular trauma including early and long-term outcome, functional analysis and quality of life (focusing on upper extremity injury)
- Neuroprotection in spinal cord ischemia (in a mouse model)
- Screening of families with members with premature coronary artery disease, premature cerebrovascular disease

General Facts

This summary of scientific work at the Department of Vascular Surgery shall be seen as supplement and extension of the scientific report from the years 2013/2014.

In addition to the previously elaborated scientific aims of our research unit we meanwhile stepped into the topic of stem cells in the treatment of patients with critical limb ischaemia.

One of our major research interests still lies in the treatment of patients with stenosis of the internal carotid artery (ICA). The two competing treatment techniques (carotid endarterectomy and carotid artery stenting) are still being compared to one another to find the ideal treatment technique for each individual patient.

Neuroprotection in spinal cord ischaemia is a relevant topic in vascular surgery.

Therefore a mouse model was established to investigate the protective effect of tetrahydrobiopterin.

A positive family history for atherosclerotic diseases delineates a relevant risk for individuals to also suffer from cardiovascular complications. This risk is especially high if cardiovascular complications among relatives occurred in young ages. We are planning to participate in the EVA (Early Vascular Aging) study (in cooperation with Prof. Dr. U. Kiechl-Kohlendorfer and PD. M. Knoflach).

Research

Bone Marrow Derived Stem Cell

PD Dr. Rantner

Patients with critical limb ischemia frequently lack the opportunity for manual revascularisation using surgical bypass or endovascular methods to improve limb perfusion. This might be due to repetitive surgical and endovascular treatments which failed over time or due to the absence of viable blood vessels in the calf. This is especially true for patients with additional diabetes mellitus. A relevant number of those patients suffer from major amputation. The intra-arterial application of bone marrow derived stem cells (specially treated as Rexmyelocel-T) is supposed to improve the blood flow to previously ischaemic tissue by angiogenesis. To follow this research question we participate in a multicentre trial. Study kick off will be in June this year.

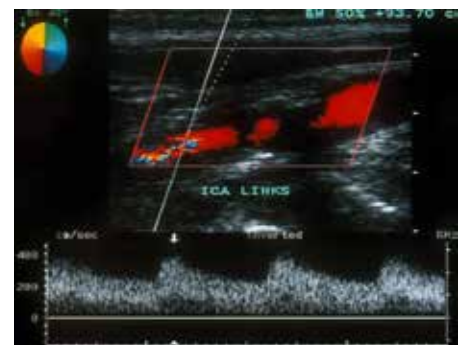

Fig. 1: Sonography and intraoperative view of a symptomatic carotid stenosis

Carotid Artery Disease

PD Dr. Rantner

We already put a lot of effort into the question of the optimal timing of treatment in patients with symptomatic ICA stenosis. Results from the CSTC (Carotid Stenosis Trialists' Collaboration) are currently under revision in "Stroke".

Additionally we meanwhile participate in the ACST-2 (Asymptomatic Carotid Surgery Trial). In this international multicentre trial patients with asymptomatic stenosis of the internal carotid artery are randomized towards carotid endarterectomy or carotid artery stenting. With this trial the safety and efficacy of carotid artery stenting in stroke prevention will be investigated and compared to carotid endarterectomy. We entered the trial in November 2015 and included 21 patients so far.

Neuroprotection in Spinal Cord Ischemia

Dr. Gratl (MUI Start), Dr. Gummerer

Neurological complications such as paraplegia as a result of spinal cord ischemia (SCI) during thoracic or thoracoabdominal aortic aneurysm repair are serious complications. Tetrahydrobiopterin (BH4) is one of five essential cofactors of the NOS and is crucial in the production of NO. It has been shown to efficiently abrogate ischemic reperfusion in transplant surgery. We therefore established a mouse model to evaluate the effect of BH4 compared to Vitamin C and saline injection. First tests to identify the optimal BH4 concentrations are finished. Histopathological examinations and immunohistochemical evaluations are still missing.

Assessment of a Positive Family History for Cardiovascular and Cerebrovascular Disease

PD Dr. Rantner

First degree relatives of patients with premature coronary artery disease (CAD) carry a substantially higher risk for CAD. It is meanwhile well known that a positive family history of disease is a relevant risk factor for incidence and prevalence of coronary heart disease and stroke. This correlation remains significant even after the correction for measured familial risk factors such as cholesterol, hypertension, obesity and diabetes. The assessment of a detailed medical family history questionnaire and a quantitative family risk score were published already in 1986. These additional assessment tools helped to improve the precision of family history as a predictor of future disease.

We plan to participate in the EVA study to assess family histories concerning premature atherosclerotic complications. All first degree relatives of patients with premature coronary artery disease and premature cerebrovascular disease are invited to participate in vascular examinations (intima media thickness, ABI, aortic stiffness,...) to assess the individual cardiovascular risk. This project is planned to be carried out as a PhD project.

Vascular Trauma

PD Dr. Klocker

Trauma mechanisms in our institution most frequently include blunt injuries, which is in contrast to other centres with mainly penetrating trauma (e.g. stab- and gunshot injuries). In blunt injuries, vascular injuries are regularly associated with bone and nerve injuries, which lead to worse functional

outcome during the long term. This is particularly important in the upper limb. Our research group analysed factors associated with poor functional outcome, and used standardised questionnaires to report on long-term quality of life, limb function and cold intolerance, which is another common finding in this setting.

Selected Publications

Long-term Clinical Outcome and Functional Status After Arterial Reconstruction in Upper Extremity Injury

Frech, A., Pellegrini, L., Fraedrich, G., Goebel, G., Klocker, J., EUROPEAN JOURNAL OF VASCULAR AND ENDOVASCULAR SURGERY: 2016; 52: S. 119-123

Association between age and risk of stroke or death from carotid endarterectomy and carotid stenting: a meta-analysis of pooled patient data from four randomised trials

Howard, George, Roubin, Gary S., Jansen, Olav, Hendrikse, Jeroen, Halliday, Alison, Fraedrich, Gustav, Eckstein, Hans-Henning, Calvet, David, Bulbulia, Richard, Bonati, Leo H., Becquemin, Jean-Pierre, Algra, Ale, Brown, Martin M., Ringleb, Peter A., Brott, Thomas G., Mas, Jean-Louis, Carotid Stenting Trialists', LANCET: 2016; 387: S. 1305-1311

Very Urgent Carotid Endarterectomy Does Not Increase the Procedural Risk

Rantner, B., Schmidauer, C., Knoflach, M., Fraedrich, G., EUROPEAN JOURNAL OF VASCULAR AND ENDOVASCULAR SURGERY: 2015; 49: S. 129-136

Functional Assessment and Evaluation of Outcome After Endovascular Therapy With Coverage of the Left Subclavian Artery in Case of Blunt Thoracic Aortic Injury.

Gombert, Alexander, Kotelis, Drosos, Griepenkerl, Ulrike M., Fraedrich, Gustav, Klocker, Josef, Glodny, Bernhard, Jacobs, Michael J., Greiner, Andreas, Grommes, Jochen, ANNALS OF VASCULAR SURGERY: 2016; [Epub ahead of print]: S.

Left ventricular ejection fraction is associated with prevalent and incident cardiovascular disease in patients with intermittent claudication - results from the CAVASIC Study

Rantner, Barbara, Pohlhammer, Johannes, Stadler, Marietta, Peric, Slobodan, Hammerer-Lercher, Angelika, Klein-Weigel, Peter, Fraedrich, Gustav, Kronenberg, Florian, Kollerits, Barbara, ATHEROSCLEROSIS: 2015; 239: S. 428-435

Collaborations

- University of Oxford, Oxford, United Kingdom (ACST-2)
- Rexgenero Limited, London, United Kingdom
- Univ. Prof. Dr. Andreas Greiner, Charité, Berlin, Germany

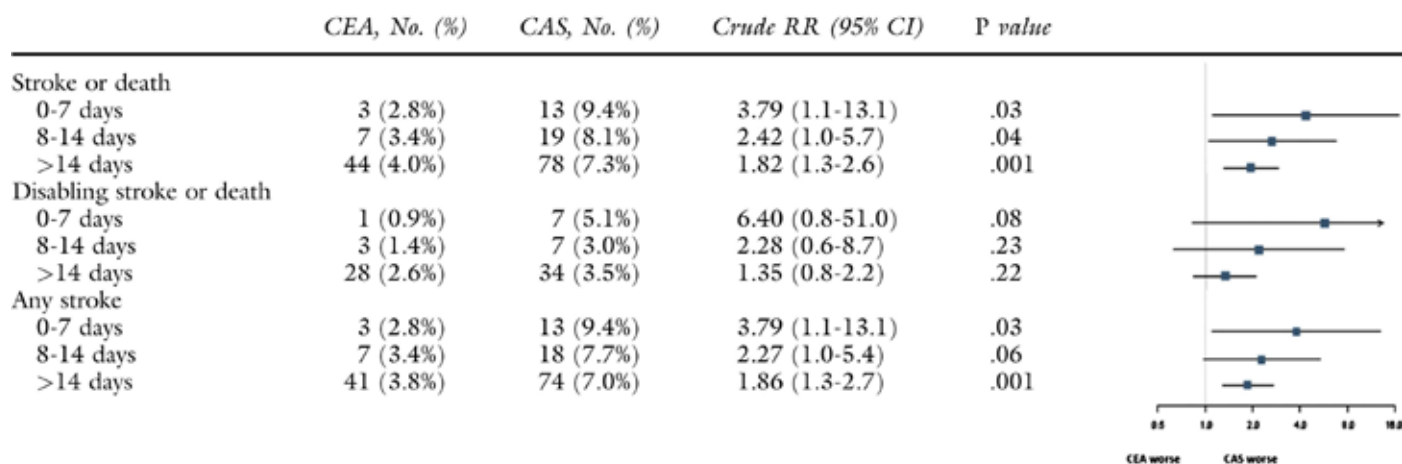

Fig. 2: The risk of stroke or death after treatment of symptomatic carotid stenoses by endarterectomy (CEA) or stenting (CAS), adopted from Rantner et al (2013).

Plastic, Reconstructive and Aesthetic Surgery



Director:
Univ.-Prof. Dr. Gerhard Pierer

Contact:
Anichstraße 35
6020 Innsbruck

Gerhard.Pierer@i-med.ac.at
Phone: +43 512 504 22731
Fax: +43 512 504 22735
www.pci.or.at



Head of Research Laboratory:
Christian Ploner, PhD

Contact:
Anichstraße 35
6020 Innsbruck

Christian.Ploner@i-med.ac.at
Phone: +43 512 504 82648
Fax: +43 512 504 22735

Research Branch (ÖSTAT Classification)

106018, 106039, 302062

Keywords

Adipose tissue, adipose derived stem cells, wound healing, immune cells, transplantation, implants, congenital deformities, thoracic wall deformities, cytokines

Research Focus

- Physiology of fat tissue resident mesenchymal stem cells and adipocytes and their impact on wound healing.
- Repair of congenital thoracic wall deformities and consequences on cardiopulmonary function and quality of life.
- Immuno-Biocompatibility of implant surfaces.

General Facts

VISION

The ISO-9001:2008 certified research unit of the Plastic, Reconstructive and Aesthetic Surgery was established in autumn 2011, enabling dedicated doctoral researches to follow clinical goals on a sound scientific basis. Our vision is to apply basic research techniques to address clinical challenges and translate these findings into new therapeutic approaches.

AIMS

1. Defining the role of Adipocytes in wound healing of chronic wounds

The fat tissue has a great impact on physiological and psychological processes in the human body. We address the question how cellular and secretory components of the fat tissue influence the healing of chronic wounds and interact with the immune system.

2. Surgical correction of congenital thoracic wall deformities and its impact on physical and physiological health

We address the question how surgery of chest wall deformities impacts on cardiopulmonary and psychological parameters and quality of life.

3. Immuno-Biocompatibility of implant surfaces

The aim is to determine whether/how implant surfaces impact on the activity of immune cells.

STRUCTURE

Three research groups equivalent to the 3

major units of the Department, ie. the units for Breast/Limb/Nerve-Surgery, Congenital Deformities – Reconstructive Surgery and Wound management/healing are supported by the research laboratory unit headed by C.Ploner, PhD. The laboratory staff comprises one Senior Postdoc, one clinical PhD student, one technical assistance (BMA) and 3 clinical researchers.

Research

The Impact of Fat Tissue on Wound Healing and Tumorigenesis

Christian Ploner (PI), Evi Morandi (PhD-Student), Susanne Lobenwein (BMA)

Despite great advances in tissue-engineering of the skin, impaired wound healing still remains one of the most serious problems in plastic surgery. We are primarily interested in defining mechanisms of (chronic) wound healing, especially delineating the role of the fat tissue in this complex cellular interplay. Disesteemed for many years as tissue exclusively dedicated to energy storage, the white adipose tissue (WAT) has become one of the most studied tissues, as recent reports uncovered its metabolic and endocrine functions *in-vivo* as well as its importance for the development of metabolic disorders, control of immune response and wound healing. In addition, fat tissue harbors a high number of easily accessible, undifferentiated adipose derived stem cells (ADSC) that are presently being tested in clinical applications, including wound healing approaches. However, isolated transplantation of these cells in wound beds only marginally enhanced the healing process, and cells embedded in engineered matrices stayed entrapped and impacted on wound healing rather by secretory action than by proliferation or differentiation. Therefore we initiated a project focusing on wound matrix controlled molecular processes affecting the regenerative potential of distinct cutaneous (keratinocytes, fibroblasts) and subcutaneous cell types (adipocytes, ADSC). One of the most important matrix components for dermal wound healing is fibronectin, a high molecular weight glycoprotein, which is recognized by specific cell surface proteins of the integrin family, namely integrin alpha 5 and alpha V. In our most recent publication we delineated the function of these integrins for ADSC physiology and identified intracellular pathways associated with these two integrins. We now aim to address these effects in other primary human cell types important for the wound healing process, in order to gain more knowledge on the molecular mechanisms activated by

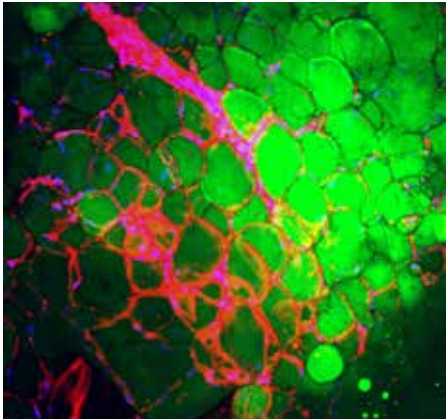

Fig. 1: Live tissue staining of human white adipose tissue imaged by use of confocal microscopy [in cooperation with M. Hermann (Department of Anesthesiology and Critical Care Medicine, Medical University Innsbruck)]. Adipocytes were stained with BODIPY 493 (green), nuclei with Höchst 33342 (blue), and cell-membranes (glycoproteins) with Wheat Germ Agglutinin Alexa-Fluor-647 (red).

contact with different extracellular matrix constituents. In a second study we investigate how tumor cells from distinct origins (multiple myeloma, breast cancer, prostate cancer or ovarian cancer) affect proximal mesenchymal stem cells and adipocytes. We are especially interested in the mechanisms by which tumor cell secreted cytokines affect adipocyte differentiation and delipidation at the molecular level. We found that cytokines secreted by tumor cells promote adipocyte differentiation and alter the development and maturation of lipid droplets within differentiating adipocytes. We are presently screening for those cytokines that are responsible for this effect, intending to identify new molecules/pathways targeting the tumor-adipocyte interaction.

Cardiopulmonary Function after Chest Wall Deformity Surgery

Barbara Del Frari (PI), Stephan Sigl (PhD-student), Anton Schwabegger (Senior PI)

Pectus excavatum and carinatum are the most common types of congenital anterior chest wall deformities. These deformities often present not only as an aesthetic disturbance but are also associated with obstructive pulmonary mechanics and abnormal cardiac physiology. The frequency of thoracoplasties has increased due to improving experience and to modified surgical techniques. The aim of our prospective study is to evaluate the effect of surgical repair on the pectus excavatum and pectus carinatum deformity itself and whether

there is a consequent change of pulmonary function and quality of life in patients. In the study all patients will undergo preoperative and postoperative evaluation with Computed Tomography CT scan, pulmonary function test and cycle ergometry in an upright and furthermore in a supine position, as well as transthoracic echocardiogram. Additionally, all patients will fill out a pre- and postoperative standardized questionnaire (including quality of life, patient’s satisfaction and physical activity) and be examined by a professional psychologist. We hypothesize that our results will provide evidence that pulmonary function is related to the depth of the depression or protrusion and is probably causal for functional deficits, and might explain why repair of the defect can result in improved pulmonary function, exercise tolerance and quality of life.

Optimization of Silicone Breast Implants by Surface-Dependent Immunoregulation

Dolores Wolfram (PI), Giuseppe Cappellano (Senior Postdoc)

This project aims to improve the immunological biocompatibility of silicone mammary implants (SMIs). We investigate the effect of different silicone surfaces used in the SMI production from different companies on T-cell activity, with specific focus on regulatory T-cells (Tregs). Tregs are known key players in the initial stages of peri-SMI fibrosis and act immunosuppressively by controlling the activation of other lymphocytes. Since implants after insertion are exposed to blood, which contains proteins interacting with the implant-surface, we

want to investigate whether coating these implants with different extracellular matrix substrates prior to exposure to serum proteins alters the activity of T-cells or impact on monocyte/macrophage attachment. Importantly, we also aim to define molecular mechanisms that are responsible for the different activation of Treg-cells, to gain fundamental scientific knowledge about smart surface coatings of implants.

Selected Publications

ITGA5 and ITGA5 diversely regulate proliferation and adipogenic differentiation of human adipose derived stem cells
Morandi, E. M., Verstappen, R., Zwierzina, M. E., Geley, S., Pierer, G., Ploner, C., SCIENTIFIC REPORTS: 2016; 6: S. 28889

Differentiation between Acute Skin Rejection in Allotransplantation and T-Cell Mediated Skin Inflammation Based on Gene Expression Analysis
Wolfram, Dolores, Morandi, Evi M., Eberhart, Nadine, Hautz, Theresa, Hackl, Hubert, Zelger, Bettina, Riede, Gregor, Wächter, Tanja, Dubrac, Sandrine, Ploner, Christian, Pierer, Gerhard, Schneeberger, Stefan, BIOMED RESEARCH INTERNATIONAL: 2015; S. 259160

Complications Related to Pectus Carinatum Correction: Lessons Learned from 15 Years’ Experience. Management and Literature Review
Del Frari, Barbara, Sigl, Stephan, Schwabegger, Anton H., PLASTIC AND RECONSTRUCTIVE SURGERY: 2016; 138: S. 317E-329E

Pectus excavatum repair from a plastic surgeon’s perspective
Schwabegger, Anton H., ANNALS OF CARDIOTHORACIC SURGERY: 2016; 5: S. 501-512

The versatility of the medial thigh lift for defect coverage in the genito-perineal region
Djedovic G, Del Frari B, Matiasek J, Schiltz D, Engelhardt T, Pierer G, Rieger UM
Int Wound J. 2016 Aug 1. doi: 10.1111/iwj.12634. [Epub ahead of print]

Collaborations

Prof. Fiona Watt, Kings College, London, UK
Prof. H.C. Hennies, University of Huddersfield, Huddersfield, UK
Prof. W.P. Andrew Lee, Johns Hopkins University, Baltimore, USA
Prof. Gerhard Brandacher, Johns Hopkins University, Baltimore, USA

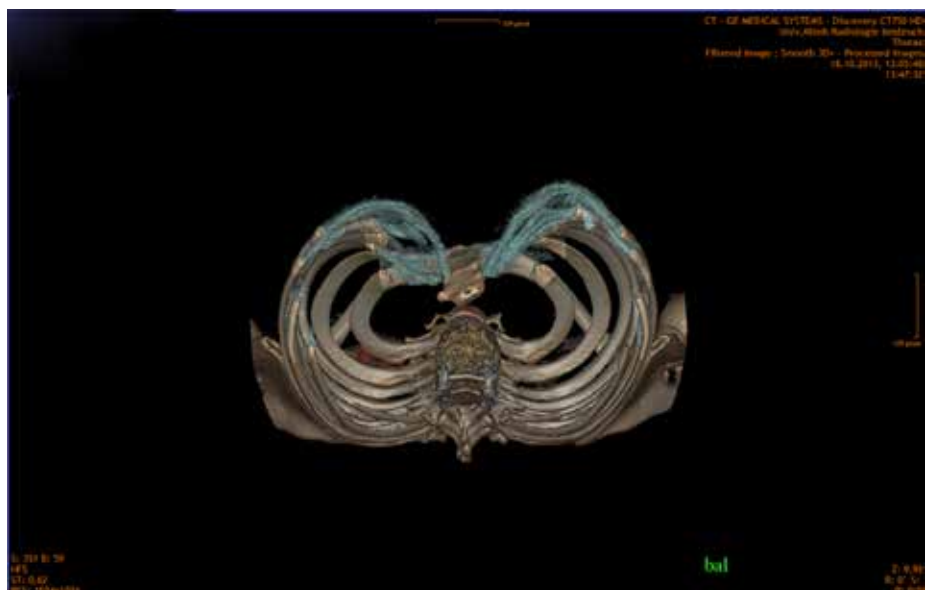

Fig. 2: Preoperative 3D VR-CT scan of a 13-year old male with an asymmetrical funnel chest.

Trauma Surgery



Director:
Univ.-Prof. Dr. Michael Blauth

Contact:
Anichstraße 35
6020 Innsbruck

Michael.Blauth@i-med.ac.at
Phone: +43 512 504 22821
Fax: +43 512 504 22824
www.unfallchirurgie-innsbruck.at

Research Branch (ÖSTAT Classifications)

106049, 211904, 302019,
302085, 305908

Keywords

Clinical studies, biomechanics, fracture fixation, cell biology, osteoporosis, geriatric patients

Research Focus

Research in the Department of Trauma Surgery focuses on the evaluation, development and improvement of new and existing treatments and therapies for traumatic and degenerative musculoskeletal diseases, not exclusively, however, with focus on geriatric patients.

General Facts

In the clinical routine setting the department is organised into teams specialised in anatomical regions. The clinical patient based research, as well as the applied and basic research of all the clinical teams at the department, is supported by an infrastructure consisting of a clinical study and documentation unit, a biomechanics labo-

ratory, a morphology and cell biology laboratory and the Core facility Micro CT. This setting supports clinical research, as well as laboratory research on macroscopic, microscopic and cellular level.

Clinical research in Trauma Surgery represents a special challenge, because of its high throughput of in- and out-patients and its wide range of treatment modalities. The main research fields are medical device studies and investigator-initiated trials which explore new treatment methods. Our study coordinators ("study nurses") support clinical staff in the organization and administration of clinical trials, ensuring a complete collection and archiving of data and patient follow-ups according to the "Good Clinical Practice" guidelines and legal requirements. The clinical study centre unit was certified in 2011 by the Clinical Research Organization "AO Foundation". The main collaborators are the Clinical Trial Center of the Medical University Innsbruck and the AO foundation/Trauma.

In the biomechanics laboratory material testing machines are available for *in vitro* testing of soft and hard biological tissues, with several custom-made test setups for various anatomical regions as well as joint simulators for the spine, shoulder and hand. These allow *in vitro* functional evaluation of interventional surgical procedures for the stabilisation or reconstruction of joints as well as of soft and hard tissue. Research projects have been carried out in collaboration with the Dept. of Anatomy and Embryology, Dept. of Neurosurgery, Dept. of Craniofacial Surgery and Dept. of Orthopaedic Surgery.

The main focus of the morphological/cell biological laboratory lies on basic research into osteoporosis and its underlying mechanisms and the resulting stem cell differentiation defects, as well as on research on intervertebral discs. To conduct these studies a fully equipped tissue culture unit is at our disposal for adult stem cell differentiation experiments and investigations on intervertebral disc cells. In addition histological, ultrastructural and biochemical analysis can be carried out. Research projects have been carried out in collaboration with the Dept. of Anatomy, Histology and Embryology, Dept. of Therapeutic Radiology and Oncology, Dept. of Plastic-, Reconstructive- and Aesthetic Surgery, as well as with several groups of the CCB.

Research

Clinical Studies and Documentation Unit

Mariette Fasser, MSc

In recent years the focus of clinical studies in trauma surgery has no longer been limited to medical device investigations: due to growing experience and know-how, an expansion to interdisciplinary projects and further aims became possible. One example is the EU-funded DO-HEALTH study which is focused on Vitamin D supplementation, Omega 3 intake and home exercise as prophylactic measures aiding healthy aging (study goals: to reduce risk of falls, to improve cognitive impairment and cardiovascular improvement). The involvement of the department in this project was a new approach and opened doors for similar highly representative epidemiological projects. However, the main research focus continues to be on musculoskeletal topics, with investigations of trauma related research questions e.g. fixation of distal radius fractures, studies on proximal humerus fractures with focus on osteoporotic bone and loss of fracture reduction implant failure and steps to prevent fixation failure.

Biomechanics Laboratory

Werner Schmölz, Assoc. Prof., PhD, Dipl.-Ing (FH)

Implant anchorage in spinal stabilisation procedures in patients having reduced bone quality still poses a challenge to the surgeons. Therefore, a new test setup was developed which allows the application



Fig.2: In vitro test set-up used to apply physiological loading to pedicle screws and provoke screw loosening. Red arrows show the load application and the pivot axis to allow a tilting motion of the screw in the vertebral body.

of physiologic pedicle screw loading and is capable of reproducing the mechanism of pedicle screw loosening seen in clinical practice. Various augmentation techniques and materials as well as screw designs to enhance pedicle screw anchorage were investigated. It could be shown that augmentation significantly improves screw anchorage and while for PMMA as augmentation material the technique is only of secondary importance, for other augmentation materials e.g. silicon, the enhancement strongly depends on the augmentation technique applied. To improve instrumentation for cervical and lumbar spinal fusion procedures, experiments were conducted *in vitro* to investigate the primary and secondary stiffness of various supplementary instrumentations. Based on the results, recommendations on the type of instrumentations and their stiffness were given.

After surgical treatment of cruciate ligament injuries, graft elongation and graft fixation affect post-surgical joint stability. Therefore, currently established and recently developed new graft preparation techniques, as well as femoral and tibial graft-bone fixation techniques, were investigated in experiments *in vitro*. It could be shown that a graft preparation technique which had recently been developed for less invasive surgery resulted in an increased graft elongation after surgical treatment.

Morphology and Cell Biology Laboratory

Hannes L. Ebner, PhD

To optimise future treatment of osteoporosis, the potential of aminobisphosphonates to enhance the development of bone-forming osteoblasts from progenitor cells was evaluated. The aminobisphosphonates investigated significantly enhanced osteoblast formation and thus provide further insights into their possible mode of action in the treatment of osteoporosis.

Adipose-derived stromal cells (ASCs) are increasingly being used for orthopaedic-based tissue engineering, due to their ability readily to undergo osteogenic differentiation. We used *in vitro* and *in vivo* approaches to evaluate the use of ASCs as a treatment strategy for age-related osteoporosis. When differentiated in conditioned culture media harvested from osteoporotic patient-derived human ASCs, osteoporotic patient-derived human bone marrow stromal cells showed a significant improvement in their osteogenic potential. These findings support the use of ASCs as an autologous cell-based approach for the treatment of osteoporosis.

The behaviour of bovine disc cells, and changes in disc matrix following *in vitro* compression, were tested to compare the findings to data on human intervertebral discs (IVD) after burst fracture of the cervical spine. Specimens were studied macroscopically, histologically, and ultrastructurally to define healthy cells, balloon cells, and disc cell death (DCD). There was a positive correlation between DCD and absorbed energy in all compartments of bovine discs. Both species showed similar patterns of DCD in the different compartments as well as similarities in cell morphologies and in matrix damage.

„Local Remodelling and Mechano-Regulation of Bone Fracture Healing in Healthy, Aged, and Osteoporotic Humans“

Univ.-Prof. Dr. Michael Blauth

Currently there is little knowledge of fracture healing, even though the radius fracture is one of the most human fractures. Age-related and osteoporotic changes in bone can interfere with the healing process and thus, fractures become a serious problem in our aging society. A high-resolution computed tomography (HR-pQCT) helps us to assess the bone microstructure in patients. This will elucidate local bone fracture healing and help investigating whether age and osteoporosis affect the healing process. Besides time-lapse CT images we acquire corresponding biomarker measurements and clinical evaluation in patients

Selected Publications

Injectable collagenase *Clostridium histolyticum* as a nonsurgical treatment for Dupuytren's disease

Arora, R., Kaiser, P., Kastenberger, T. -J., Schmiedle, G., Erhart, S., Gabl, M., OPERATIVE ORTHOPÄDIE UND TRAUMATOLOGIE: 2016; 28: S. 30-37

What is the optimal salvage procedure for cut-out after surgical fixation of trochanteric fractures with the PFNA or TFN? A multicentre study

Brunner, Alexander, Buettler, Markus, Lehmann, Uwe, Frei, Hans, Curd, Kratter, Renato, Di Lazzaro, Marco, Scola, Alexander, Sermon, An, Attal, Rene, INJURY-INTERNATIONAL JOURNAL OF THE CARE OF THE INJURED: 2016; 47: S. 432-438

A Simple Method for Measurement of Femoral Anteverision-Validation and Assessment of Reproducibility

Brunner, Alexander, Eichinger, Martin, Hengg, Clemens, Hoermann, Romed, Brenner, Erich, Kralinger, Franz, JOURNAL OF ORTHOPAEDIC TRAUMA: 2016; 30: S. E273-E278

The J-Shaped Bone Graft for Anatomic Glenoid Reconstruction A 10-Year Clinical Follow-up and Computed Tomography-Osteoabsorptiometry Study

Deml, Christian, Kaiser, Peter, van Leeuwen, Wouter F., Zitterl, Magdalena, Euler, Simon A., Doz, Priv, AMERICAN JOURNAL OF SPORTS MEDICINE: 2016; 44: S. 2778-2783

Allograft augmentation in proximal humerus fractures

Euler, S. A., Kralinger, F. S., Hengg, C., Wambacher, M., Blauth, M., OPERATIVE ORTHOPÄDIE UND TRAUMATOLOGIE: 2016; 28: S. 153-163

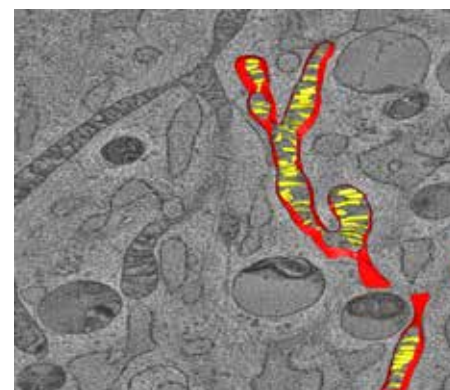

© European Spine Journal

Fig. 3: 3D reconstruction of a section from a mesenchymal stem cell, based on an electron tomogram, showing a single, branched, threadlike mitochondrion with cristae, marked here in yellow, and mitochondrial membrane, in red.

with wrist fractures. This will ultimately allow better monitoring of the repair process to improve clinical diagnosis and prognosis. A broad range of expertise will be provided in a Swiss-Austrian-German DACH collaboration, where ETH Zurich, the Medical University Innsbruck, the Inselspital Bern, and Ulm University combine their strengths.

Selected Funding

DO-HEALTH, EU- 7th framework, <http://www.do-health.eu>

Collaborations

Clinical Investigation Unit:

- AO Foundation/Trauma

Morphology and Cell Biology Laboratory:

- Prof. Dr. med. B. von Rechenberg, University of Zürich, Zürich, Swisse
- Prof. Dr. med. P. Pietschmann, MedUni Wien, Wien, Austria
- Priv.-Doz. Dr. P. J. Richards, University of Zürich, Zürich, Swisse
- Priv. Doz. Dr. G. Krumschnabel, Oroboros Labs, Innsbruck, Austria

Biomechanics Laboratory:

- Prof. Dr. med. Tobias Schulte, University of Münster, Germany
- Prof. Ralph Müller, ETH, Zürich, Swisse
- Priv.-Doz. Dr. med Heiko Koller, Bad Wildungen, Germany
- Priv. Doz. Dr. med Stefan Freude, University of Tübingen, Germany
- Dr. med. Richard Bostelmann, University of Düsseldorf, DE
- Dr. med Claudia Druschel, Charite University medicine, Berlin, Germany
- Dr. Kanna Gnanalingham, Dept of Neurosurgery, Manchester, UK

Core Facilities

MicroCT

Urology



Director:
Univ.-Prof. Dr. Wolfgang Horninger

Contact:
Anichstraße 35
6020 Innsbruck

Wolfgang.Horninger@i-med.ac.at
Phone: +43 512 504 24811
Fax: +43 512 504 24873
www.uro-innsbruck.at

Research Branch (ÖSTAT Classification)

302086, 301103, 302013,
305904, 603124

Keywords

Prostate cancer, bladder cancer, tumor markers, androgen receptor, cytokines, growth factors, uro-onco-immunology

Research Focus

- Prostate cancer treatment and therapy resistance mechanisms
- Androgen receptor signaling and its role in prostate cancer development, therapy and therapy resistance
- Tumor immunology and immunotherapy with a focus on dendritic cells, $\gamma\delta$ -T-lymphocytes and BCG instillation therapy in NMIBC
- Diagnostics and tumor markers for urological tumors, in prostate cancer and bladder cancer

General Facts

The Innsbruck Department of Urology was founded in 1964 under the direction of Hans Marberger. Georg Bartsch was director from 1988 to 2010 and since 2011 the

Urological Department is directed by Wolfgang Horninger.

The Department covers the entire diagnostic and therapeutic range of urology, running five operating theaters, urological and neuro-urological outpatient clinics, two adult urological wards, and a pediatric ward. The Division of Experimental Urology is integrated in the Department of Urology. A main focus of the Department is the treatment of urological malignancies. In 1993, the European Prostate Center Innsbruck was founded in order to ensure optimal patient care and clinical research on prostate cancer and prostatic diseases. In addition to the diagnosis and treatment of prostate diseases, a prostate cancer-screening project called Tyrol Project was implemented in 1993 to offer early detection and curative treatment of prostate cancer for affected men.

Reconstructive Urology covers surgical repair of the urogenital tract after trauma or for treatment of incontinence, whereas neuro-urology treats patients with functional disorders of the bladder and the sphincter. Pediatric Urology offers diagnoses and treatments for all congenital, as well as acquired genitourinary problems, from birth to adulthood.

Research

Prostate Cancer Screening

Wolfgang Horninger, Jasmin Bectic

More than 20 years after the introduction of prostate specific antigen (PSA) testing in clinical practice, early detection of prostate cancer is still a matter of debate.

Some prostate cancer-screening studies, mainly conducted in Europe, showed a decrease in prostate cancer mortality and a stage migration towards lower, potentially curable prostate cancer stages at the time of diagnosis.

However, the same studies showed a considerable number of overdiagnoses and overtreatments.

Our own data ("Prostate Cancer demonstration Project", "Tyrol Study") showed that 20 years after initiation of an area-wide early detection program, a 64% decrease in prostate cancer mortality was achieved. Overdiagnosis was seen in 16-20% of all screened men.

Therefore, the aim of our Prostate Cancer Unit is to identify new, better markers for prostate cancer.

Moreover, we try to optimize prostate cancer detection (multiparametric MRI, mpMRI) and prostate cancer treatment to avoid overdiagnosis and reduce the side effects of (over)-treatment.

Establishment of Novel Biomarker in Predicting response to Bacillus Calmette-Guérin (BCG) Therapy in high risk, non-muscle invasive bladder cancer (NMIBC)

Renate Pichler

Bladder Cancer is the second most common diagnosed urological cancer.

While NMIBC can be cured endoscopically by surgery and intravesical installation therapy, patients with BCG refractory NMIBC have a significant higher probability of cancer specific mortality. Current research focuses on the understanding of the exact immune mechanism of BCG induced antitumor activity.

The Androgen Receptor - Key Regulator in Prostate Cancer

Helmut Klocker

The androgen receptor (AR), a hormone induced transcription factor, is intimately linked to prostate cancer and is the primary therapeutic target in this malignancy. For two decades, researchers of the Department of Urology have been contributing to worldwide efforts to elucidate the molecular mechanism of AR function and its role in progression and therapy resistance. Several mechanisms have been identified and were the basis for the development of new AR targeting drugs that led to prolonged survival of patients.

Current research is focused on the AR transcriptome. This includes protein-coding genes, such as AGR2 (Anterior Gradient 2), a cellular chaperone, which is a potential tumor

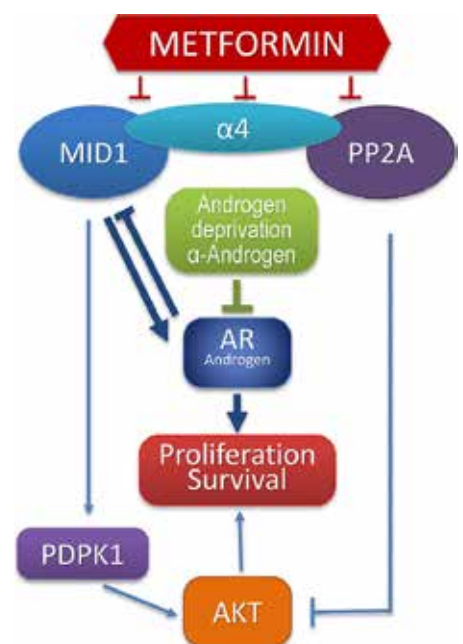

Fig. 1: Posttranslational feedback-regulation of androgen receptor

marker, or microRNA genes, such as the host genes of miR22 and miR29a, two epigenetic regulators involved in invasion and apoptosis, respectively. Investigation of posttranslational regulation of AR protein and activity uncovered a feed-back-loop regulation, which is potentially targetable by the well-known diabetes drug, metformin (Fig. 1).

Cytokines and Growth Factors in Prostate Cancer

Zoran Culig

Researchers are primarily interested in the regulation of cellular events by cytokines in castration therapy-resistant prostate cancer. There is a particular focus on interleukin-6, whose levels are up-regulated in prostate malignancy, and on endogenous regulators of cytokine signaling. In this context, it is especially interesting that these molecules are implicated in the acquisition of resistance to chemotherapy with docetaxel (Fig.2). In order to improve therapy in advanced prostate cancer, inhibition of growth factors and other oncogenes up-regulated during prostate cancer

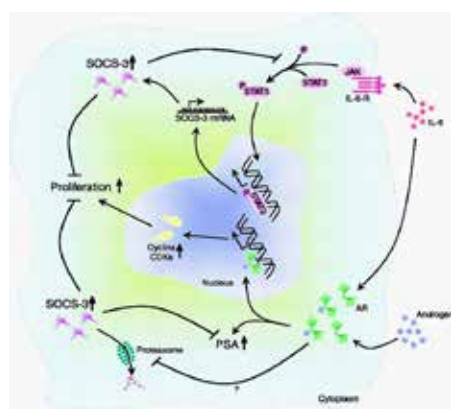

Fig.2: SOCS-3 function in prostate cancer. SOCS-3 is a common negative regulator for androgen and IL-6 pathways in prostate cancer.

progression by androgen ablation therapy are investigated. Combination therapies will be developed in the future in order to establish personalized therapies. This research work, performed in several projects, received numerous international recognitions for its contribution to the current understanding of prostate cancer development and progression.

Models for Prostate Cancer Research

Iris E. Eder-Neuwirt

In-vitro prostate cancer research is mainly conducted with immortalized cell lines, which lose relevant growth characteristics when grown on a plastic surface. In addition, the human prostate is composed not only of epithelial cells, but also contains

several types of stromal cells. In tumor tissue, the interplay between the epithelium and the stroma is thought to create an optimal microenvironment for tumor growth and progression driven by “activated” stromal cells. Hence, the use of 3D co-culture systems for in vitro cancer research is a highly important issue when studying the molecular changes occurring in the different cell types as well as for testing novel therapies and drugs.

Recently 3D prostate cancer organoid culture protocols were established. The studies have shown that the molecular expression pattern of cell type specific markers is markedly altered in 3D versus 2D cultures. In addition, androgen responsiveness, as well as drug responses, are significantly changed in 3D epithelial-stromal co-culture organoids, suggesting a strong influence of fibroblasts on tumor cell behavior (Fig.3). Future goals will focus on the interplay between epithelial cells and fibroblasts using this 3D cell culture system with the aim of improving responsiveness to current therapies.

Immunology and Immunotherapy of Urological Tumors

Martin Thurnher

The immunology/immunotherapy group has a research interest in how the immune system reacts against growing tumors. Specifically, they are interested in the activation of yo-T-lymphocytes by intermediates of the mevalonate pathway (Fig. 4).

Since deregulation of mevalonate metabolism can lead to malignant transformation, yo-T-cells also play an important role in the immunosurveillance of tumors, such as bladder cancer. Improved understanding of these interactions will foster the development of innovative immunotherapies, as well as the establishment of prognostic markers and monitoring technologies.

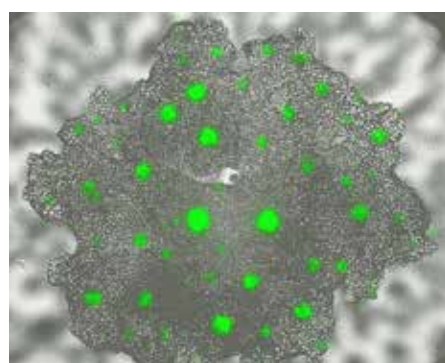

Fig. 3: LNCaP prostate cancer epithelial cells co-cultured with GFP-labeled cancer associated fibroblasts (CAF) at a ratio of 1:1 in 3D Perfecta 96 well plates

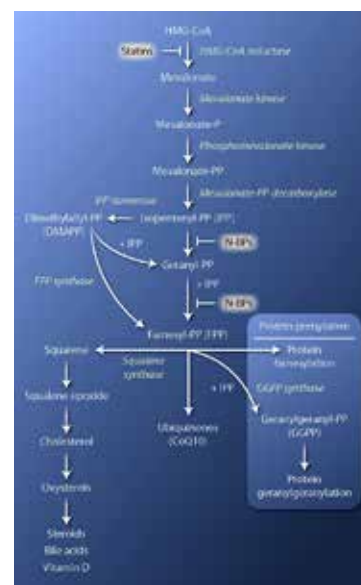

Fig. 4: Mevalonate metabolism

Selected Publications

High incidence of clinically significant concomitant prostate cancer in patients undergoing radical cystectomy for bladder cancer: A 10-year single-center experience. Heidegger I, Oberaigner W, Horninger W, Pichler R. Urol Oncol. 2016 Dec 10. pii: S1078-1439(16)30370-2. doi: 10.1016/j.urolonc.2016.11.004. [Epub ahead of print]

Is Eotaxin-1 a serum and urinary biomarker for prostate cancer detection and recurrence? Heidegger I, Höfer J, Luger M, Pichler R, Klocker H, Horninger W, Steiner E, Jochberger S, Culig Z. Prostate. 2015 Dec;75(16):1904-9.

Age-Adjusted PSA Levels in Prostate Cancer Prediction: Updated Results of the Tyrol Prostate Cancer Early Detection Program Heidegger I, Fritz J, Klocker H, Pichler R, Bektic J, Horninger W. PLoS One. 2015 Jul 28;10(7).

PSA Isoforms' Velocities for Early Diagnosis of Prostate Cancer. Heidegger I, Klocker H, Pichler R, Horninger W, Bektic J. Anticancer Res. 2015 Jun;35(6):3567-70.

The ONCOTYROL Prostate Cancer Outcome and Policy Model: Effect of Prevalence Assumptions on the Benefit-Harm Balance of Screening. Mühlberger N, Kurtzthaler C, Iskandar R, Krahn MD, Bremner KE, Oberaigner W, Klocker H, Horninger W, Conrads-Frank A, Sroczyński G, Siebert U. Med Decis Making. 2015 Aug;35(6):758-72.

For all publications look at: <https://urologielabor-innsbruck.tirol.kliniken.at/page.cfm?vpath=publikationen-gesamtuebersicht>

Selected Funding

- Austrian Research Fund, FWF
- K1 Center Oncotyrol
- MUI Start Grant Fund
- Tyrolean Research Fund
- Tyrolean Cancer Society (Krebshilfe Tirol)
- Research Fund of the Austrian National Bank
- Medical Research Fund (MFF)
- Astellas Pharma Investigator Driven Grant

Collaborations

- Holger Süttmann, DKFZ Heidelberg, D
- Mark A. Rubin, Weill Cornell Medical College, New York US
- Michal R. Schweiger & Hans Lehrach, MPI for Molecular Genetics, Berlin, D
- William R.G. Watson, Conway Institute of the University College Dublin, IRE
- Francesca Demicheli, University of Trento, I
- Christian Fuchsberger & Johannes Rainer, EURAC Bolzano, I
- Narisu Narisu, NIH Bethesda, US
- Glen Kristiansen, University of Bonn, D
- Normam, J. Maitland, University of York, UK
- Andrew C.B. Cato, Karlsruhe Institute of Technology, D
- Jan Bouchal, University of Olomouc, CR
- Philip A. Cole, Johns Hopkins University, Baltimore, USA

Orthopedic Surgery



Director:
Univ.-Prof. Dr. Martin Krismer

Contact:
Anichstraße 35
6020 Innsbruck

Viktoria.Mader@i-med.ac.at
Phone: +43 512 504 22691
Fax: +43 512 504 22701
www.orthopaedie-innsbruck.at



Head of Experimental Orthopaedics:
Univ.-Prof. Dr. Michael Nogler

Contact:
Innrain 36
6020 Innsbruck

Michael.Nogler@i-med.ac.at
Phone: +43 512 9003 71691
Fax: +43 512 9003 73691

Research Branch (ÖSTAT Classification)

302057, 303020, 301902,
302048, 206001

Keywords

Orthopaedics, medical microbiology, immunology, minimal-invasive surgery, biomedical engineering

Research Focus

Clinical Research

We perform applied studies mainly in the fields of spine, arthroplasty, knee, and paediatric orthopaedics, with a special interest in infection, implant migration and postoperative car driving ability.

Experimental Orthopaedics

Two main research areas are investigated at the Experimental Orthopaedics laboratories. The area of biomedical engineering focuses on biomechanical studies aiming to increase allograft stability in difficult revision cases and to improve techniques and instruments for bone removal. The area of Implant-related infections develops studies on detection, prevention and treatment of infections related to biofilm attachment.

General Facts

Clinical Research

In addition to a new VICON system in clinical use, we perform gait and motion analysis in our Biomechanics Lab (Dr. Haid) and outdoor with a Lukotronic system.

Implant migration measurement based on EBRA was developed and is being developed in cooperation with the Unit of Geometry and CAD at Innsbruck University (Prof. Husty). Software and scanning equipment are available.

Brake reaction time for car driving is measured in an experimental setting with high accuracy. Postoperative measurements have been performed for various operations.

Experimental Orthopaedics

The unit of Experimental Orthopaedics is a research department within the Department of Orthopaedic Surgery of the Innsbruck Medical University. The unit is divided into two major research areas. The area of biomedical engineering, coordinated by Dr. Putzer, focuses on improving techniques for filling bony defects and bone removal in the field of orthopaedics. The research

focuses on biomechanical studies aiming to increase allograft stability in difficult revision cases and to improve techniques and instruments for bone removal. The area of implant-related infections, coordinated by Dr. Coraça-Huber, develops studies aimed at the understanding of biofilm building and attachment on biomaterial surfaces. For that, different biofilm models are carried out using the main strains associated with implant-related infections. Prevention and treatment, as well as antibiotic and anti-septic susceptibility tests, can be carried out for systemic or local therapy. Also, diagnostic techniques are being studied aimed at the reduction of false negatives in implant-associated infections. For that, molecular identification of biofilms are in development. Research in the immunological field of implant-related infections has also been carried out. The aims are detecting immune activation parameters as a sign of infection and monocyte differentiation and activation in co-evolution with microbial infection.

Research

Biofilm Formation and Antimicrobial Susceptibility Tests

Improved understanding of the structure of biofilms and how they function will help to develop treatments to eliminate biofilms from implant surfaces. *In vitro* models of biofilms allow the testing of antimicrobial susceptibility and the analysis of biofilm architecture and molecular behaviour. In this kind of study, we investigated whether biofilms grow *in vitro* on metal discs and on microtiter plates. The evaluation of the biofilms formed on different surfaces was assessed by comparing the antibiotic susceptibility of *S. aureus* and by examining the structure of *S. aureus* biofilms grown by scanning electron microscopy (SEM). Also, several biomaterials can be tested for biofilm growth and efficacy tests for biomaterials with antimicrobial properties.

Biofilms-Specific Genes and the Diagnosis of PJI

A staphylococcal bacterial biofilm is produced in a two-step process: initial bacterial attachment to the surface of a foreign body or host tissue followed by a biofilm formation, consisting of bacterial proliferation, intercellular adhesion, and extracellular slime substance production. The primary attachment to a surface is related to a cell surface protein exhibiting autolysin/adhesin and fibrinogen-binding activity. This protein autolysin-E (AtlE) is encoded by the chromosomal *atlE* gene. Initial adhesion is

feasible molecular methods, like polymerase chain reaction (PCR). Our objective with this research area is to develop a new PCR method by detecting biofilm markers from the joint aspirates of PJI patients.

Immunology of Biofilm Infection

Here we study the interaction of the complement system with bacteria in nosocomial joint infections. We will try to create means to improve the complement mediated lysis of the bacteria. Thus, results achieved during this study will not only broaden the basic knowledge about complement in nosocomial joint infections but also have clinical implications. Ultimately this induction of CML might make it possible to heal infections *in vivo* making graft renewal unnecessary. This study not only increases our knowledge about interactions of bacteria causing nosocomial infection with the innate immune system but can ultimately lead to the development of a novel, indirect detection strategy. This strategy could be transferred into the clinical setting adding to direct bacteriologic testing and thus helping reduce the number of false negative samples drawn from patients after joint reconstruction surgery.

Bone Tissue as Antibiotic Carrier

In orthopaedic surgery, bone grafts are used for reconstructing bone defects caused by

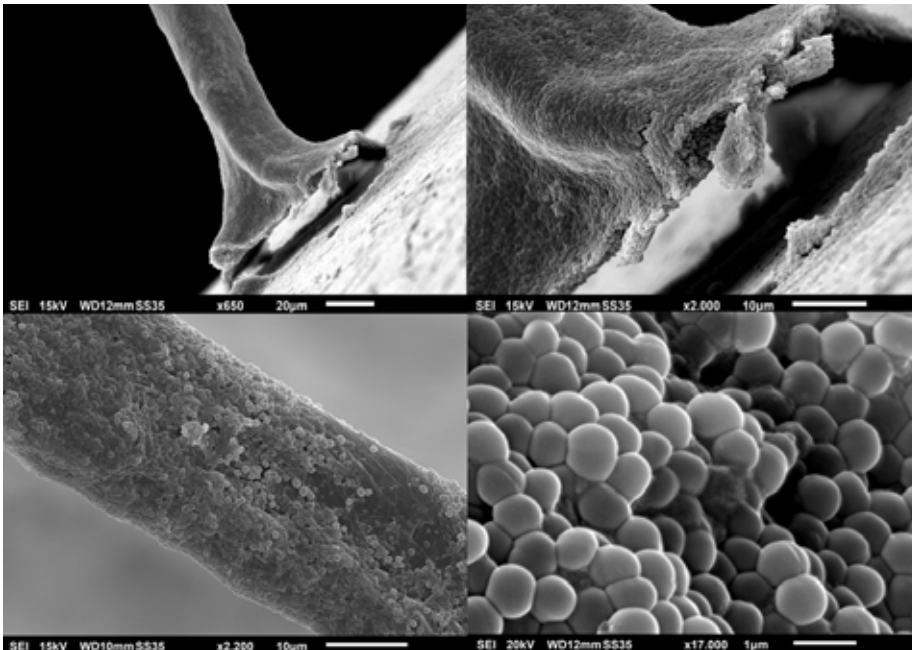

Fig. 1: *S. epidermidis* biofilm

mediated not only by the AtIe itself but also via its enzymatic function. The hydrolysis of the cell wall peptidoglycan leads to autolysis and thus to the release of extracellular DNA (eDNA), which has been shown to be an important component of staphylococcal biofilms. The second stage of biofilm formation demonstrated that cell aggregation and biofilm accumulation were mediated by the products of the chromosomal *ica* gene locus, which is composed of four genes organised in an operon structure (*icaA*, *icaD*, *icaB* and *icaC*). The *icaADBC* operon leads to the production of polysaccharide intercellular adhesin (PIA), also known as poly-N-acetyl glucosamine (PNAG). Despite the undeniably important role of the *icaADBC* operon controlling PIA/PNAG production in staphylococcal biofilms, the existence of a PIA/PNAG-independent biofilm mechanism is known. Other important genes associated with biofilm formation and the accumulation phase in *S. epidermidis* are *aap*, *fbe* and *embp*, encoding accumulation adhesion protein (Aap), fibrinogen binding protein (Fbe) and extracellular matrix-binding protein (Embp), respectively. Embp is characterised as a giant 1MDa extracellular protein and is sufficient for biofilm formation in *icaADBC*- and *aap*-negative *S. epidermidis*. Potentially, as Embp and PIA can function as intercellular adhesins independently or parallel, Embp in combination with PIA can be used for development of a polyvalent *S. epidermidis* vaccine, for example, and improve diagnostic techniques. In the final phase of biofilm growth, cells

dispersed from a mature biofilm regain the physiological characteristics of planktonic cells and may disseminate to new locations thereby causing acute infection. Although biofilm-specific genes have been investigated, none of this knowledge has been used to develop new PJI diagnostics. These biofilm-specific markers can be detected by

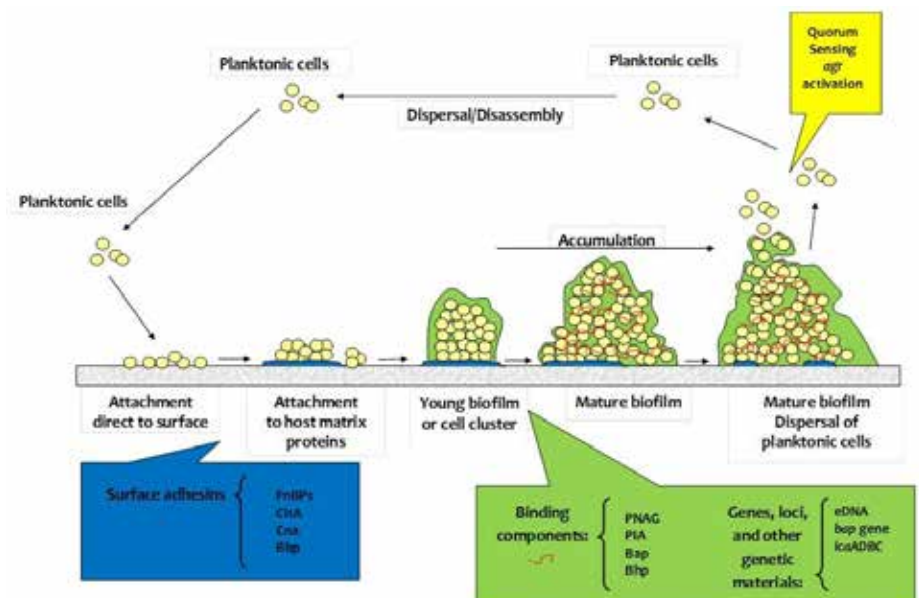

Fig.2: *Staphylococcal* biofilm life cycle (FnBPs – fibronectin binding proteins; C1A – fibrinogen-binding protein-clumping factor A; Cna – collagen binding protein; Bbp – bone sialoprotein-binding protein; PNAG – poly-N-acetylglucosamine; PIA – polysaccharide intercellular adhesion; Bap – biofilm associated protein; Bhp – Bap homologue protein; eDNA – extracellular DNA; *icaADBC* – genes involved in the synthesis of PIA; *bap* gene – involved in the synthesis of Bap).

implant associated complications, trauma and tumours. While autografts can be used, donor site morbidity can be avoided using allografts. Bone grafts can either be used as large structural bone grafts from post-mortem donors or as bone chips from morselized femoral head donated by living patients undergoing total hip arthroplasty. Such bone chips are used to fill defects that require biomechanical stability, which can be achieved by compressing the chips into the defect site. Fresh frozen bone chips are preferred because they contain the original osteoconductive and osteoinductive proteins. However, fresh frozen chips can add the risk of local contaminations. Surgery with bone allografts is complex and time-consuming; therefore it is prone to a higher infection rate (2.0–2.5%). Antibiotics delivered from an implanted biomaterial can be potentially used to prevent infections, providing high concentrations of antibiotics at the surgical site without local or systemic toxicity. In addition, these materials should be osteoconductive and osteoinductive, thus supporting bone healing without further surgery. Morselized bone allografts can be used as carriers by impregnating them with antibiotic solutions or by mixing them with antibiotic powders. Also, biomechanical compression tests were carried out for different preparation procedures to study the mechanical effect of grain size distribution, water and fat content and the possibility of enhancing osteoconductive and osteoinductive properties of allograft by adding bioglass or platelet rich plasma.

Computer-Assisted Bone Removal Procedures

An analysis of orthopaedic surgical procedures resulted in a limited subset of planning functions for bone removal procedures. One research focus is dedicated to computer interaction in the operation room. New measurement technologies can provide more information to smart instruments, which can enhance surgical skill resulting in more precise bone removal procedures.

A simulation study determined the maximum reachable depth of straight instruments inserted into the femoral canal. In this case, constraints for a simulated bone removal procedure in a femoral canal were determined. For the detection of additional constraints, a new technology for the detection of the soft tissue envelope during hip arthroplasty was evaluated in a cadaver study. In almost every surgical procedure retraction of soft tissue is necessary. To

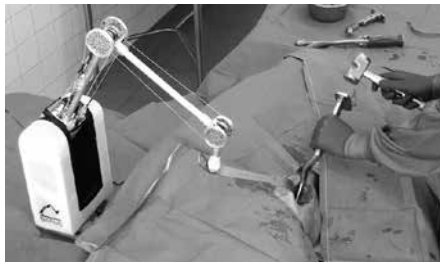

© Journal Surgical Innovation

Fig. 3: Retracting soft tissue in minimally invasive hip arthroplasty using a bionic inspired concept of a robotic arm.

control retraction forces and minimise soft tissue damages related to it, the possibility of using a semiactive robotic retractor holder was evaluated in a concept study.

Improvement of Current Orthopaedic Therapies

By developing or evaluating new technologies and surgical instruments orthopaedic treatments can be improved. Understanding the effects of radial shock wave therapies on the human body are currently evaluated in a patient model. Additionally, ideas for the improvement of current orthopaedic procedures or surgical instruments are collected. So far, five innovative ideas for new instruments have been awarded with the CAST award.

Brake Response Times after Various Surgeries (Different Authors)

Brake response times were recorded for different orthopaedics braces (ankle, knee) and therapeutic shoes.

Selected Publications

Lyophilized allogeneic bone tissue as an antibiotic carrier
Coraca-Huber, Debora C., Ammann, Christoph G., Nogler, Michael, Fille, Manfred, Frommelt, Lars, Kuehn, Klaus-Dieter, Foelsch, Christian,
CELL AND TISSUE BANKING: 2016; 17: S. 629-642

BAG-S53P4 as an additive to bone allografts: A laboratory study using an uniaxial compression test
David, Putzer, Johannes, Fuchs, Debora, Coraca-Huber, Ammann, Christoph, Michael, Liebensteiner, Michael, Nogler,
JOURNAL OF ORTHOPAEDIC RESEARCH: 2015; 33: S. 1875-1879

Retracting Soft Tissue in Minimally Invasive Hip Arthroplasty Using a Robotic Arm: A Comparison Between a Semiactive Retractor Holder and Human Assistants in a Cadaver Study
Putzer, David, Klug, Sebastian, Haselbacher, Matthias, Mayr, Eckart, Nogler, Michael,
SURGICAL INNOVATION: 2015; 22: S. 500-507

Collaborations

- Heraeus Medical GmbH, Wehrheim, Germany
- Incocon GmbH, Attnang-Puchheim, Austria

Devices & Services

- Zeiss Fluorescence Microscope Axio Lab.A1
- Scanning Electron Microscope JSM-6010 InTouchScope
- Ultraschall-Spezialgerät Bandelin B
- Plantar Measurement System Novel
- 3D Printer Formlabs
- VICON Nexus 2.1.1 gait lab with 2 Amti OR6-7-1000 ground reaction force measurement plates
- Lukotronic motion analysis for outdoor use
- Brake reaction time measurement setting

Anaesthesiology and Critical Care Medicine



Director:
o. Univ.-Prof. Dr. Karl Lindner

Contact:
Anichstraße 35
6020 Innsbruck

anaesthesie@i-med.ac.at
Phone: +43 512 504 28503
Fax: +43 512 504 28504
www.anaesthesie-innsbruck.at

Research Branch (ÖSTAT Classification)

302004, 302053, 302074, 302058

Keywords

Anaesthesiology, critical care medicine, emergency medicine, pain medicine, palliative care, breathing gas, coagulation

Research Focus

Anaesthesiology, critical care medicine, emergency medicine, pain medicine, palliative care, cardiopulmonary resuscitation, airway management, vasodilatory shock, post-traumatic shock, coagulation, hypothermia, regional anaesthesia, transplantation, neuro- and obstetrical anaesthesia, muscle relaxants, mountain rescue, microcirculation, prediction models, breathing gas analysis.

General Facts

The department performs about 40.000 anaesthesia cases per year in 60 operating and diagnostic rooms. Being a university hospital, the department covers all surgical disciplines, is responsible for six postoperative care units, three intensive care units (general surgery, trauma and transplantation critical care units), two shock rooms, ground emergency service at two different locations (Innsbruck and Telfs), a rotor wing unit, a pain unit and an anaesthesia outpatient clinic. Additionally, our physicians have teaching responsibilities (anaesthesia classes for medical students), perform special skills trainings (first aid classes, ventilation management classes, basic life and advanced life support trainings) and perform bedside teaching for our medical students during their mandatory anaesthesiology rotation. In addition, the Department of Anaesthesiology and Critical Care Medicine runs an experimental laboratory for basic science research and a large animal operating room.

Research

As can be anticipated from the section above, the Department of Anaesthesiology and Critical Care Medicine covers a large variety of different activities, including all clinical aspects of anaesthesia procedures, postoperative care, intensive care medicine, emergency medicine, teaching responsibilities and various research activities. It should be noted that all anaesthesiologists involved in research activities (including basic science and clinical research) are primarily employed as physicians and clinical care providers. Only a limited part

of their regular working hours is dedicated to research activities. The total amount of so called "research time" for each employee varies between 10% of total working hours for a first-year resident up to 40% of total working hours for a few attending physicians who have achieved certain scientific accomplishments (publications, successful grant applications, research awards). This means that the Department of Anaesthesiology and Critical Care Medicine does not employ full time researchers.

The Department however, is affiliated with the "Institute of breath gas analysis" (Chair: Prof. Christopher Mayhew). This basic science research group shares the basic science laboratory with the Department of Anaesthesiology and Critical Care Medicine and employs 8 full time researchers. There are several joint collaborations and projects with this institute.

Due to the various specialty fields and topics in anaesthesiology, researchers of our Department cover many different research aspects. The following list gives an overview of the different research groups and topics of interest:

Research Group Dr. Peter Mair

(Main Focus: Mountain Emergency Medicine)

- Initiation and start of the „**International Alpine Trauma Registry**“, a prospective multicentre observational study about preclinical care of severely injured people in the alpine setting. This is a joint project with the Institute for alpine emergency medicine of the EURAC in Bozen, South Tyrol, Italy.
- Collaboration and recruitment of patients for the „**International Hypothermia Registry**“. This prospective multicentre observational study of the University of Geneva, Switzerland, collaborates with many European centres to provide clinical care of severely hypothermic patients
- **Extracorporeal life support during shock and cardiopulmonary resuscitation.** This is a joint project with the university clinic for cardiac surgery, Innsbruck
- **"Preclinical and clinical treatment of avalanche victims"**: a retrospective analysis with the Institute for alpine emergency medicine of the EURAC in Bozen, South Tyrol, Italy.
- **Cerebral monitoring during cardiopulmonary resuscitation:** experimental studies led by Dr. Gabriel Putzer, Clinic for Anaesthesiology and Critical Care Medicine.

Research Group Dr. Corinna Velick-Salchner and Dr. Helmuth Tauber
(Main Focus: Coagulopathy in Cardiac and Vascular Surgery)

- Stress response in patients undergoing carotid endarterectomy in regional anaesthesia versus general anaesthesia: a randomized prospective observational study.
- Acquired von Willebrand Syndrome (AVWS) in patients with ECMO/ECLS.
- Transcranial Doppler analysis in patients undergoing carotid endarterectomy in regional anaesthesia versus general anaesthesia: a randomized prospective observational study.
- Administration of von Willebrand factor concentrate in bleeding patients on ECMO/ECLS.
- Correlation of fibrinogen levels and chest tube drainage in children undergoing congenital heart surgery: A retrospective analysis.

Research Group Dr. Petra Innerhofer and Dr. Elgar Oswald
(Main Focus: Trauma Induced Coagulopathy)
Reversal of trauma induced coagulopathy (RETIC study).

Research Group Dr. Karl-Heinz Stadlbauer
(Main Focus: Treatment of Haemorrhagic Shock in Trauma Patients, Anaesthesia in Vascular Surgery)

- **The “VITRIS trial”**: The role of vasopressin as on top-medication during life threatening haemorrhagic shock in trauma.
- **The “PLATA trial”**: Peripheral nerve block for prevention of phantom limb pain after transtibial amputation.

Research Group Dr. Judith Martini
(Main Focus: Coagulation and Microcirculation)

- **Shiga toxin and its interaction with plasmatic coagulation – Is shortening of clotting time and binding of antithrombin and heparin by Shiga toxin 2 a key event in haemolytic uremic syndrome?** Cooperation with The Division of Hygiene and Medical Microbiology, Medical University Innsbruck
- **The effect of plasma expanding solutions on clot structure: The view through the confocal microscope.**
- **Contrast media induced acute effects on chronic kidney injury – A pilot study in pigs.** Cooperation with the University Clinic for Radiology, Innsbruck
- **IVUS guided transcatheter aortic valve implantation – A feasibility study in pigs.** Cooperation with the University Clinic of Cardiac Surgery, Innsbruck.

Research Group Dr. Thomas Luger
(Main Focus: Anaesthesia in Geriatric Patients; Emergency Medicine under extreme Conditions)

- Ultrasound guided regional anaesthesia in a glucose-6 phosphate dehydrogenase deficient geriatric trauma patient.
- Pneumothorax and ultrasound guided interscalenus block.
- Tensionpneumothorax. A simulation study.
- Emergency medicine under extreme conditions (the MARS Analogue Simulation).
- Multidisciplinary management of geriatric fractures. A joint project with the university clinic of traumatology, Innsbruck.
- Psychological support during long distance sailing.

Research Group Dr. Axel Kleinsasser
(Main Focus: High Altitude Medicine and Postoperative Care)

- Cardiorespiratory fitness in high altitude.
- Stress response in patients undergoing carotid endarterectomy in regional anaesthesia versus general anaesthesia: a randomized prospective observational study.

Research Group Dr. Ruth Kröss
(Main Focus: Paediatric Anaesthesia)

- Study investigator for **NECTARINE: Neonate-Children sTudy of Anaesthesia pRactice IN Europe**. Epidemiology of morbidity and mortality in neonatal anaesthesia: A European prospective multicentre observational study led by the European Society of Anesthesiology (ESA).
- Study investigator for **APRICOT: Anaesthesia PRactice In Children Observational Trial**: European prospective multicentre observational study: Epidemiology of severe critical events, led by the European Society of Anaesthesiology (ESA).
- Assessment of soft tissue and bone diameter for intraosseous needles in children and adults. A retrospective single-centre observational study. In collaboration with Dr. Peter Paal, Krankenhaus der Barmherzigen Brüder, Salzburg.

Research Group Dr. Michael Baubin
(Main Focus: Emergency Medicine, Quality Assessment)

- Contribution to the **“German cardiopulmonary resuscitation registry”**
- Development of performance indicators for quality assessment of emergency medical services.

Research Group Dr. Wolfgang Lederer
(Main Focus: Emergency Medicine; Obstetric Anaesthesia)

- Assessment of biomarkers in cerebrospinal fluid during pregnancy.
- Systemic hypotension following intravenous administration of non-ionic contrast medium during computed tomography.
- Airway management by laryngeal tube during out-of-hospital cardiac arrest
- A comparison of Narkotrend, BIS and NIRS during neurointerventional procedures
- Breath analysis and evaporation
- Vasopressin and leucocyte function
- AED instructions for first responders and recommendations for basic life support

Research Group Dr. Günther Putz
(Main Focus: Obstetric Anaesthesia)
Changes of biomarkers in cerebrospinal fluid during preeclampsia.

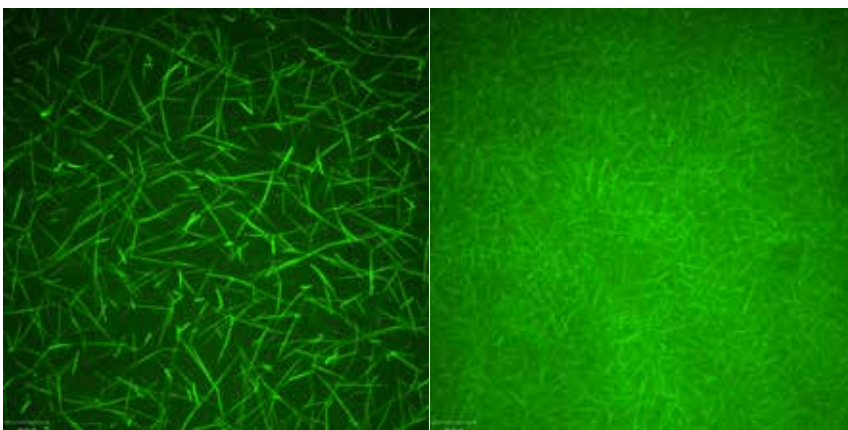

© Martin Hermann

Fig. 1: Real Time Live Confocal Imaging showing the plasticity of fibrin networks

Research Group Dr. Stefan Jochberger

(Main Focus: Gynaecology and Obstetric Anaesthesia)

- Pain management during labour.
- State of the art obstetric anaesthesia.
- “Status quo” of obstetric anaesthesia in Austria.
- Sugammadex and its effects on contraceptive plasma hormone levels upon reversal of rocuronium bromide.
- Do erythrocyte concentrates, fresh frozen plasma and platelet concentrates contain CCL 11?

Research Group Dr. Janett Kreutziger

(Main Focus: Emergency Medicine)

- The importance of blood glucose levels in the prehospital management of trauma patients
- A comparison of endotracheal intubation with videolaryngoscopy (McGrath®) versus conventional laryngoscopy for prehospital intubation of emergency patients in air rescue. A multicenter, prospective, randomized trial. Cooperation with H. Trimmel, Hospital Wiener Neustadt, Vienna, Austria.
- Use of the GlideScope Ranger Video Laryngoscope for Emergency Intubation in the Prehospital Setting: A Randomized Control Trial. Cooperation with H. Trimmel, Hospital Wiener Neustadt, Vienna, Austria.
- Crowdfunding for financing hospital infrastructures – An international comparison.
- Comparison of interscalenus block with general anesthesia and intravenous anesthesia for ambulant shoulder repositioning.
- Inflammatory parameters in necrotizing fasciitis. Collaboration with the Department of Anesthesia Bern, Switzerland.

Research Group Dr. Franz Wiedermann and Dr. Martina Stichlberger

(Main Focus: Effects of Vasopressin)

- Development of an agonist and antagonist of procalcitonin/vasopressin in a bioassay: migration of human monocytes in response to procalcitonin and its fragments.
- Effects of Vasopressin on migration of human leukocytes.

Research Group Dr. Stephan Eschertzhuber

(Main Focus: Anaesthesia for Solid Organ Transplantation, Postoperative Care of Transplant Patients)

- Concentrations of echinocandins in ascites, pleural effusion, bile, wound secretion and cerebrospinal fluid – a pilot study. Collaboration with the University Clinic of Internal Medicine and the Division of Hygiene and clinical microbiology.

- Pharmacokinetics of trimethoprim-sulfamethoxazole in critically ill patients with continuous veno-venous haemofiltration. Collaboration with the University Clinic of Internal Medicine.
- Infectious complications after heart transplantation.

Research Group Dr. Gabriel Putzer and Dr. Patrick Braun

(Main Focus: Cardiopulmonary Resuscitation)

- Monitoring of brain oxygenation during hypothermic CPR.
- Publication trends in the G20 countries
- CANAP Study: Cannabinoids as premedication and PONV prophylaxis in patients undergoing general anesthesia.
- Near infrared spectroscopy (NIRS) in children. Correlation between NIRS and anesthesia depth in children between 0-3 years of age.
- HUP vs. SUP study. Effect of head up positioning versus supine positioning on brain oxygenation and metabolism during experimental cardiopulmonary resuscitation.
- Contrast media induced acute effects on chronic kidney injury – A pilot study in pigs. Cooperation with the University Clinic for Radiology, Innsbruck
- IVUS guided transcatheter aortic valve implantation – A feasibility study in pigs. Cooperation with the University Clinic of Cardiac Surgery, Innsbruck.
- Near infrared spectroscopy (NIRS) in patients undergoing carotid endarterectomy under regional anaesthesia.
- EVITA vs. EVONE. Two different ventilation concepts and their influence on atelectasis in pigs.
- True CPR simulation study. Conventional CPR versus True CPR during patient transport in the ambulance.

Institute of Breath Gas Analysis

Dr. Christopher Mayhew

- *In vitro* studies of volatile components of bacteria or different cell lines.
- Detection of human volatile components of breath or urine after natural disasters (e.g. earthquakes)
- Anaesthesiological monitoring of breath after surgical procedures.

Selected Publications

Results of rotational thromboelastometry, coagulation activation markers and thrombin generation assays in orthopedic patients during thromboprophylaxis with rivaroxaban and enoxaparin: a prospective cohort study
Oswald, Elgar, Velik-Salchner, Corinna, Innerhofer, Petra, Tauber, Helmut, Auckenthaler, Thomas, Ulmer, Hanno, Streif, Werner, BLOOD COAGULATION & FIBRINOLYSIS: 2015; 26: S. 136-144

Thrombolysis and clinical outcome in patients with stroke after implementation of the Tyrol Stroke Pathway: a retrospective observational study

Willeit J, Geley T, Schöch J, Rinner H, Tür A, Kreuzer H, Thiemann N, Knoflach M, Toell T, Pechlaner R, Willeit K, Klingler N, Praxmarer S, Baubin M, Beck G, Berek K, Dengg C, Engelhardt K, Erlacher T, Fluckinger T, Grander W, Grossmann J, Kathrein H, Kaiser N, Matosevic B, Matzak H, Mayr M, Perfler R, Poewe W, Rauter A, Schoenherr G, Schoenherr HR, Schinnerl A, Spiss H, Thurner T, Vergeiner G, Werner P, Wöll E, Willeit P, Kiechl S. LANCET NEUROLOGY: 2015; 1: S 48-56

Admission blood glucose predicted haemorrhagic shock in multiple trauma patients

Kreutziger, Janett, Rafetseder, Andreas, Mathis, Simon, Wenzel, Volker, El Attal, Rene, Schmid, Stefan, INJURY-INTERNATIONAL JOURNAL OF THE CARE OF THE INJURED: 2015; 46: S. 15-20

Extracorporeal Membrane Oxygenation Induces Short-Term Loss of High-Molecular-Weight von Willebrand Factor Multimers

Tauber, Helmut, Ott, Helmut, Streif, Werner, Weigel, Guenter, Loacker, Lorin, Fritz, Josef, Heinz, Anneliese, Velik-Salchner, Corinna, ANESTHESIA AND ANALGESIA: 2015; 120: S. 730-736

Efficacy of Argatroban in Critically Ill Patients with Heparin Resistance: A Retrospective Analysis

Treichl, Benjamin, Bachler, Mirjam, Lorenz, Ingo, Friesenecker, Barbara, Oswald, Elgar, Schlimp, Christoph J., Pedross, Florian, Fries, Dietmar, SEMINARS IN THROMBOSIS AND HEMOSTASIS: 2015; 41: S. 61-67

Outcome of avalanche victims with out-of-hospital cardiac arrest

Moroder, Luca, Mair, Birgit, Brugger, Hermann, Voelckel, Wolfgang, Mair, Peter, RESUSCITATION: 2015; 89: S. 114-118

Bronchoalveolar Lavage Fluid (1,3)beta-D-Glucan for the Diagnosis of Invasive Fungal Infections in Solid Organ Transplantation: A Prospective Multicenter Study

Mutschlechner, Wolfgang, Risslegger, Brigitte, Willinger, Birgit, Hoenigl, Martin, Bucher, Brigitte, Eschertzhuber, Stephan, Lass-Floerl, Cornelia, TRANSPLANTATION: 2015; 99: S. E140-E144

Delayed and intermittent CPR for severe accidental hypothermia

Gordon, Les, Paal, Peter, Ellerton, John A., Brugger, Hermann, Peek, Giles J., Zafren, Ken, RESUSCITATION: 2015; 90: S. 46-49

Is epinephrine during cardiac arrest associated with worse outcomes in resuscitated patients? Effect of vasopressin and catecholamines on the migration of leukocytes

Wiedermann FJ, Stichlberger M, Lederer W. CRITICAL CARE: 2015; 19: S. 120

Computed advisory systems in daily practice for predicting concentrations and effects of combined anesthetics: a new field in anesthesia?

Velik-Salchner, C., MINERVA ANESTESIOLOGICA: 2015; 81: S. 1151-1152

Multicenter evaluation of a lateral-flow device test for diagnosing invasive pulmonary aspergillosis in ICU patients

Eigl, Susanne, Prattes, Juergen, Lackner, Michaela, Willinger, Birgit, Spiess, Birgit, Reinwald, Mark, Seltsch, Brigitte, Meilinger, Michael, Neumeister, Peter, Reischies, Frederike, Woelfler, Albert, Raggam, Reinhard B., Flick, Holger, Eschertzhuber, Stephan, Krause, Robert, Buchheidt, Dieter, Thornton, Christopher R., Lass-Floerl, Cornelia, Hoenigl, Martin, CRITICAL CARE: 2015; 19: S. 178

Ultrasound-guided regional anesthesia for carotid endarterectomy induces early hemodynamic and stress hormone changes

Hoefler, Judith, Pierer, Eve, Rantner, Barbara, Stadlbauer, Karl-Heinz, Fraedrich, Gustav, Fritz, Josef, Kleinsasser, Axel, Velik-Salchner, Corinna, JOURNAL OF VASCULAR SURGERY: 2015; 62: S. 57-67

European Resuscitation Council Guidelines for Resuscitation 2015 Section 4. Cardiac arrest in special circumstances
 Truhlar, Anatolij, Deakin, Charles D., Soar, Jasmeet, Khalifa, Gamal Eldin Abbas, Alfonso, Annette, Bierens, Joost J. L. M., Brattebo, Guttorm, Brugger, Hermann, Dunning, Joel, Hunyadi-Anticevic, Silvija, Koster, Rudolph W., Lockey, David J., Lott, Carsten, Paal, Peter, Perkins, Gavin D., Sandronis, Claudio, Thies, Karl-Christian, Zideman, David A., Nolan, Jerry P., Cardiac Arrest Special, RESUSCITATION: 2015; 95: S. 148-201

European Resuscitation Council Guidelines for Resuscitation 2015 Section 2. Adult basic life support and automated external defibrillation
 Perkins, Gavin D., Handley, Anthony J., Koster, Rudolph W., Castren, Maaret, Smyth, Michael A., Olasveengen, Theresa, Monsieurs, Koenraad G., Raffay, Violetta, Graesner, Jan-Thorsten, Wenzel, Volker, Ristagno, Giuseppe, Soar, Jasmeet, Adult Basic Life Support Automated, RESUSCITATION: 2015; 95: S. 81-99

Intracardiac Doppler Echocardiography for Monitoring of Pulmonary Artery Pressures in High-Risk Patients Undergoing Transcatheter Aortic Valve Replacement
 Mueller, Silvana, Velik-Salchner, Corinna, Edlinger, Michael, Bonaros, Nikolaos, Heinz, Anneliese, Feuchtnner, Gudrun, Bartel, Thomas, JOURNAL OF THE AMERICAN SOCIETY OF ECHOCARDIOGRAPHY: 2016; 29: S. 83-91

Intracardiac echocardiography for guidance of transcatheter aortic valve implantation under monitored sedation: a solution to a dilemma?
 Bartel, Thomas, Edris, Ahmad, Velik-Salchner, Corinna, Mueller, Silvana, EUROPEAN HEART JOURNAL-CARDIOVASCULAR IMAGING: 2016; 17: S. 1-8

Manual Versus Mechanical Chest Compressions On Surfaces Of Varying Softness With Or Without Backboards: A Randomized, Crossover Manikin Study
 Putzer, Gabriel, Fiala, Anna, Braun, Patrick, Neururer, Sabrina, Biechl, Karin, Keilig, Bernhard, Ploner, Werner, Fop, Ernst, Paal, Peter, JOURNAL OF EMERGENCY MEDICINE: 2016; 50: S. 594+

Neurophysiological effects of needle trauma and intraneural injection in a porcine model: a pilot study
 Kirchmair, L., Stroehle, M., Loescher, W. N., Kreutziger, J., Voelckel, W. G., Lirk, P., ACTA ANAESTHESIOLOGICA SCANDINAVICA: 2016; 60: S. 393-399

Functional Recovery of a Human Neonatal Heart After Severe Myocardial Infarction
 Haubner, Bernhard J., Schneider, Johanna, Schweigmann, Ulrich, Schuetz, Thomas, Dichtl, Wolfgang, Velik-Salchner, Corinna, Stein, Joerg-I., Penninger, Josef M., CIRCULATION RESEARCH: 2016; 118: S. 216-221

Effects of Stomach Inflation on Cardiopulmonary Function and Survival During Hemorrhagic Shock: A Randomized, Controlled, Porcine Study
 Braun, Patrick, Putzer, Gabriel, Strapazon, Giacomo, Wimmer, Angela, Schnell, Hermann, Arnold, Henrik, Neururer, Sabrina, Brugger, Hermann, Wenzel, Volker, Paal, Peter, SHOCK: 2016; 46: S. 99-105

Use of the GlideScope Ranger Video Laryngoscope for Emergency Intubation in the Prehospital Setting: A Randomized Control Trial
 Trimmel, Helmut, Kreutziger, Janett, Fitzka, Robert, Szuets, Stephan, Derdak, Christoph, Koch, Elisabeth, Erwied, Boris, Voelckel, Wolfgang G., CRITICAL CARE MEDICINE: 2016; 44: S. E470-E476

Monitoring of brain oxygenation during hypothermic CPR - A prospective porcine study
 Putzer, Gabriel, Braun, Patrick, Strapazon, Giacomo, Toferer, Martha, Mulino, Miriam, Glodny, Bernhard, Falk, Markus, Brugger, Hermann, Paal, Peter, Helbok, Raimund, Mair, Peter, RESUSCITATION: 2016; 104: S. 1-5

EuReCa ONE-27 Nations, ONE Europe, ONE Registry A prospective one month analysis of out-of-hospital cardiac arrest outcomes in 27 countries in Europe
 Graesner, Jan-Thorsten, Lefering, Rolf, Koster, Rudolph W., Masterson, Siobhan, Boettiger, Bernd W., Herlitz, Johan, Wnent, Jan, Tjelmeland, Ingvild B. M., Ortiz, Fernando Rosell, Maurer, Holger, Baubin, Michael, Mols, Pierre, Hadzibegovic, Irzal, Ioannides, Marios, Skulec, Roman, Wissenberg, Mads, Salo, Ari, Hubert, Herve, Nikolaos, Nikolaos I., Loczi, Gerda, Svavarsdottir, Hildigunnur, Semeraro, Federico, Wright, Peter J., Clarens, Carlo,

Pijls, Ruud, Cebula, Grzegorz, Correia, Vitor Gouveia, Cimpoesu, Diana, Raffay, Violetta, Trenkler, Stefan, Markota, Andrej, Stroemsoe, Anneli, Burkart, Roman, Perkins, Gavin D., Bossaert, Leo L., EuReCa ONE Collaborators, RESUSCITATION: 2016; 109: S. 145-146

Recommended practice for out-of-hospital emergency anaesthesia in adults: Statement from the Out-of-Hospital Emergency Anaesthesia Working Group of the Emergency Medicine Research Group of the German Society of Anaesthesiology and Intensive Care
 Hossfeld, Bjoern, Bein, Bertold, Boettiger, Bernd W., Bohn, Andreas, Fischer, Matthias, Graesner, Jan-Thorsten, Hinkelbein, Jochen, Kill, Clemens, Lott, Carsten, Popp, Erik, Roessler, Markus, Schaumberg, Alin, Wenzel, Volker, Bernhard, Michael, EUROPEAN JOURNAL OF ANAESTHESIOLOGY: 2016; 33: S. 881-897

Fibrinogen supplementation ex vivo increases clot firmness comparable to platelet transfusion in thrombocytopenia
 Schenk, B., Lindner, A. K., Treichl, B., Bachler, M., Hermann, M., Larsen, O. H., Fenger-Eriksen, C., Wally, D., Tauber, H., Velik-Salchner, C., Fries, D., BRITISH JOURNAL OF ANAESTHESIA: 2016; 117: S. 576-582

Cerebrospinal fluid levels of tau and phospho-tau-181 proteins during pregnancy
 Lederer, Wolfgang, Dominguez, Cristina Alomar, Popovscaia, Marina, Putz, Gunther, Humpel, Christian, PREGNANCY HYPERTENSION-AN INTERNATIONAL JOURNAL OF WOMENS CARDIOVASCULAR HEALTH: 2016; 6: S. 384-387

Breath analysis for in vivo detection of pathogens related to ventilator-associated pneumonia in intensive care patients: a prospective pilot study
 Filipiak, Wojciech, Beer, Ronny, Sponring, Andreas, Filipiak, Anna, Ager, Clemens, Schiefecker, Alois, Lanthaler, Simon, Helbok, Raimund, Nagl, Markus, Troppmair, Jakob, Amann, Anton, JOURNAL OF BREATH RESEARCH: 2015; 9: S. 016004

Exhaled methane concentration profiles during exercise on an ergometer
 Szabo, A., Ruzsanyi, V., Unterkofler, K., Mohacsi, A., Tuboly, E., Boros, M., Szabo, G., Hinterhuber, H., Amann, A., JOURNAL OF BREATH RESEARCH: 2015; 9: S. 016009

Hybrid Volatolomics and Disease Detection
 Broza, Yoav Y., Mochalski, Pawel, Ruzsanyi, Vera, Amann, Anton, Haick, Hossam, ANGEWANDTE CHEMIE-INTERNATIONAL EDITION: 2015; 54: S. 11036-11048

Diagnosing lactose malabsorption in children: difficulties in interpreting hydrogen breath test results
 Ruzsanyi, Veronika, Heinz-Erian, Peter, Entenmann, Andreas, Karall, Daniela, Mueller, Thomas, Schimkowitz, Alexander, Amann, Anton, Scholl-Buergi, Sabine, JOURNAL OF BREATH RESEARCH: 2016; 10: S. 016015

Devices and Services

60 operating/diagnostic rooms, general surgery, post-operative, transplantation, and trauma intensive care unit, six postanesthesia care units, anesthesiology outpatient clinic, medical and nursing student education, emergency medical service ground and rotorwing unit, pain service, basic science research laboratory, and animal operating room.

General and Surgical Critical Care Medicine



Director:
o. Univ.-Prof. Dr. Karl Lindner

Contact:
Anichstraße 35
6020 Innsbruck

anaesthesie@i-med.ac.at
Phone: +43 512 504 28503
Fax: +43 512 504 28504
<https://intensiv.tirol-kliniken.at>

Research Branch (ÖSTAT Classification)

302004, 302031, 302053,
301103, 106011

Keywords

Confocal microscopy, thromboelastometry, coagulation, intensive care medicine, fibrinogen, trauma, coagulopathy, sepsis, critical illness, fluid management

Research Focus

Our research team is dedicated to developing new strategies to improve clinical outcome focussing on coagulation management and volume replacement. Our interdisciplinary team is trying to find optimal treatment options, alternative methods and strategies to target the therapy to the individual needs of patients in the field of emergency-, perioperative- and critical care medicine. Our research involves basic experimental as well as clinical research.

General Facts

Our research projects are carried out by an

interdisciplinary team consisting of medical doctors, (molecular) biologists and (medical) students in very close collaboration. This way we can translate basic research into medical practice. Our aim is to understand the basic process of coagulation disorders with the aim of improving patient treatment. By combining clinical practice with experimental research, we evaluate novel treatment options with the long-term goal of gaining an (inter)national registration for the respective indication or medication. Head of the research laboratory with a focus on acquired coagulation disorders in critically ill patients is Ao. Univ.-Prof. Dr. Dietmar Fries. In addition to top level standard-of-care technologies for coagulation testing we were able to mobilize sufficient funds to acquire a spinning-disc confocal microscope for our laboratory. With our confocal specialist, Dr. Martin Hermann, we offer this special, life-imaging technique to various departments of the Medical University of Innsbruck as well as to external partners. Major goals regarding confocal imaging are the search for new diagnostic/prognostic methods, as well as novel staining possibilities in order to minimize animal experiments.

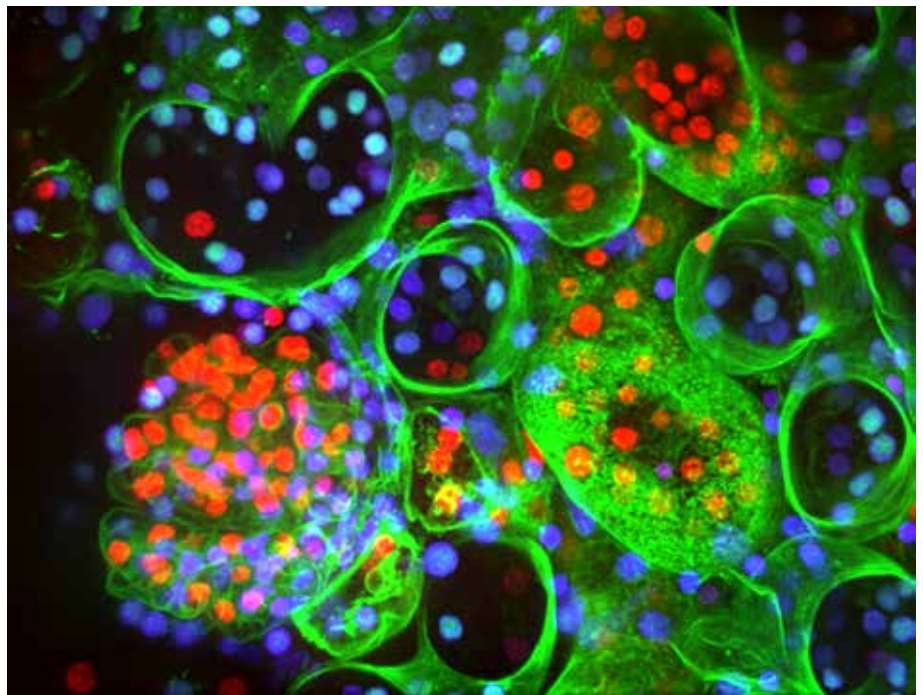

© Martin Hermann

Fig. 1: Biopsychronology of a live murine kidney biopsy using Syto 16 (blue), propidium iodide (red) and wheat germ agglutinin (green) to visualize nuclei of living/dead cells and tissue morphology. Image acquisition was performed on a confocal spinning disc microscope. This work was supported by Grants of the OeNB and the Daniel Swarovski Foundation Biopsychronology and is currently being translated into clinical practice by Dr. Rupert Oberhuber & coworkers from the VTT/DSL.

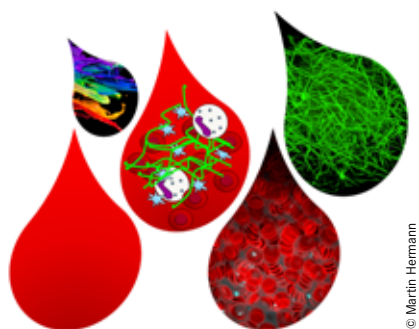

Fig. 2: Starting with a drop of blood and the addition of live stains cellular as well as molecular key players may be analyzed in real time without the need of fixation.

Research

Fibrinogen concentrate in trauma induced coagulopathy (FlinTIC study). A multicenter, multinational placebo controlled double blinded study.

Project leader: D Fries

In the event of marked blood loss fibrinogen reaches critical values as a rule more so than any other coagulation factor, or platelets. Recent clinical data showed that fibrinogen concentrate can improve clot firmness and offers a better safety profile than platelet concentrates. Therefore, the aim of this study is to assess whether fibrinogen concentrate, administered at the site of the accident, is able to improve coagulation until arrival at the hospital: Fibrinogen concentrate or placebo are administered as an infusion at the site of the accident. Patients are evaluated on blood coagulation parameters, adverse-, thrombotic- and bleeding events until seven days after inclusion. The primary endpoint is the difference in maximum clot firmness (MCF) of the fibrin clot (FIBTEM) between V1 (before study drug administration) and V2 (15 minutes after administration of the study drug) as assessed by ROTEM thromboelastometry (MCF-FIBTEM).

Argatroban in critical ill patients with heparin resistance (ArgHeR).

Project leader: D Fries and M Bachler

Despite the great advances made in anticoagulation therapy in recent years, thrombosis and pulmonary embolism remain preventable complications and significantly influence morbidity and mortality, especially in critically ill patients. An inadequate response to Heparin, known as Heparin resistance, has been reported in up to 22% of patients undergoing CPB. In the treatment and prophylaxis of venous

thromboembolism the phenomenon of Heparin resistance is responsible for insufficient antithrombotic prophylaxis or therapy. In this context, the use of direct thrombin inhibitors may be useful. Argatroban is a direct thrombin inhibitor which binds to thrombin in a rapid and reversible manner. Therefore, the aim of the planned study is to investigate whether the administration of Argatroban (Argatra®) is able to achieve a prophylactic or therapeutic antithrombotic therapy in a reasonable time period in critically ill patients, assumed to have a heparin resistance and being at risk for thrombosis or thromboembolism. The primary endpoint is to achieve the targeted aPTT of ≥ 45 seconds at 8 hours (6-8h), once the patients have a diagnosed heparin resistance and heparin dose was increased or argatroban administration started.

Rivaroxaban and PCC: Prothrombin Complex Concentrate in Patients with bleeding complications related to Rivaroxaban (Riva-PCC).

Project leader: D Fries and B Schenk

In life-threatening bleeding events, the non-vitamin K antagonist oral anticoagulants (NOACs) pose a great challenge for physicians. The aim of this study is to test for effective reversal of the NOAC rivaroxaban by use of the non-specific reversing agent PCC (prothrombin complex concentrate). Patients with life-threatening bleeding events under rivaroxaban treatment are included and 25 U kg⁻¹ of PCC administered. Blood samples are collected immediately before PCC administration and at various time points afterwards. Primary endpoint is the difference in thrombin generation (TG) before and ten minutes after administration of PCC. Thrombosis screening is performed 7 days after PCC administration via duplex ultrasound.

Ex vivo investigation of the effects of fibered embolization coils on coagulation

Project leader: B Schenk and M Freund

Endovascular embolization is a procedure to treat abnormal blood vessels in the brain and other parts of the body. It is an alternative to open surgery. It is mostly used to fill aneurysms, but also for blunt and penetrating traumatic injuries: These injuries to solid organs and extremity vessels are often managed using transcatheter arterial embolization. For a wide range of materials and clinical scenarios embolization is appropriate. Embolic agents such as coils may prove to be the safest and most effective form of therapy. In several case studies coil embolization

of the superior rectal arteries was found to be technically feasible, safe and well tolerated. Nevertheless, certain differences in the style of the various embolization coils can be found. Clinical experience showed that the thrombogenicity of embolization coils equipped with fibers is much higher than the thrombogenicity of those without fibers. Therefore, the aim of the study is to assess the change in coagulation status after treatment with embolization coil fibers (fibers) ex vivo. The primary endpoint is the difference in ROTEM EXTEM clotting time between baseline and ex vivo addition of about 30 fibers.

A retrospective analysis comparing the fibrinogen level in survivors and non-survivors during sepsis

Project leader: M Bachler and C Niederwanger

During SIRS or SEPSIS the fibrinogen levels elevate quite above the norm value range. Latest findings have revealed new roles of fibrinogen and its cleavage products in the innate immune system other than mediating the immune response and enhancing the pro-inflammatory state. Fibrinogen entraps invading pathogens when it forms a fibrin network. During coagulation and the subsequent fibrinolysis a peptide (BB15-42) cleaved from the β -chain acts as an antibiotic and maintains the endothelial barrier function, improving the endothelial tight junctions by binding to the endothelium, and may improve the outcome in septic patients. On the other hand, hyperfibrinogenemia is often associated with an increased risk for thromboembolic events and microvascular fibrin deposition during sepsis. Therefore, the aim of this study is to investigate the role of hyperfibrinogenemia during sepsis. Septic patients, hospitalized between 2000 to 2014 at the University Hospital Innsbruck (Austria) are enrolled retrospectively. The peak of the C-reactive protein (day 0) is used as indicator of the most intense period of a septic event. Data are collected on a daily basis from 3 days before (day -3) until 3 days after (day 3) the peak of the C-reactive protein. Primary endpoint is the difference in the fibrinogen level between survivors and non-survivors.

Real Time Live Confocal Microscopy

Project leader: M Hermann

Our real time live confocal microscopy approach relies on a spinning disc confocal microscope, which has been financed entirely by funds acquired from our industrial partners. Our aim is to open up a window

into the cellular/molecular universe with the goal to study cellular processes and develop new methods as well as tools for both basic science as well as prognostic/diagnostic methods suitable for clinical practice. These goals can only be achieved by close collaboration with partners within the Medical University of Innsbruck. The most recent example for such an approach is a method named “Biopsychronology” which has been developed together with the Daniel Swarovski Research Laboratory (DSL) and was presented on the cover of Transplant International, in which it was published. Positive international feedback in the form of a research highlight in Nature Reviews Nephrology, an Editor’s Choice in Science Translational Medicine and an invited chapter in Methods Molecular Biology encouraged us to continue this approach (for details see: www.clotwork.at).

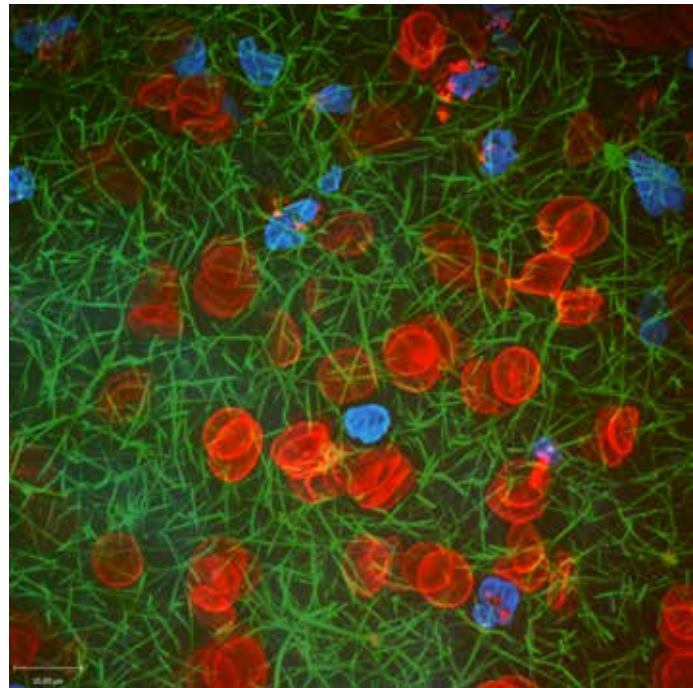

© Martin Hermann

Fig. 3: Live confocal visualization of a human blood clot showing the fibrin network (green), erythrocytes (red) and nuclei of leucocytes (blue)

Selected Publications

A Class 1 Histone Deacetylase with Potential as an Antifungal Target
 Bauer I, Varadarajan D, Pidroni A, Gross S, Vergeiner S, Faber B, Hermann M, Tribus M, Brosch G, Graessle S.
 MBIO: 2016; 7.

Fibrinogen supplementation ex vivo increases clot firmness comparable to platelet transfusion in thrombocytopenia
 Schenk B, Lindner AK, Treichl B, Bachler M, Hermann M, Larsen OH, Fenger-Eriksen C, Wally D, Tauber H, Velik-Salchner C, Fries D.
 BRITISH JOURNAL OF ANAESTHESIA: 2016; 117: S. 576-582.

Ex vivo reversal of effects of rivaroxaban evaluated using thromboelastometry and thrombin generation assay
 Schenk B, Würtinger P, Streif W, Sturm W, Fries D, Bachler M.
 BRITISH JOURNAL OF ANAESTHESIA: 2016; 117: S. 576-582.

In search for in vivo methods to visualize clot forming in cut vessels and interrupted flow.
 Solomon C, White NJ, Hochleitner G, Hermann M, Fries D.
 BRITISH JOURNAL OF ANAESTHESIA: 2016; 117: S. 554-555.

Biopsychronology: A Method Using Live Tissue Staining to Image Cell Function in the Kidney
 Ashraf MI, Fries D, Streif W, Aigner F, Hengster P, Troppmair J, Hermann M.
 METHODS IN MOLECULAR BIOLOGY: 2016;1397: S. 81-90.

Efficacy of argatroban in critically ill patients with heparin resistance: a retrospective analysis.T
 Treichl B, Bachler M, Lorenz I, Friesenecker B, Oswald E, Schlimp CJ, Pedross F, Fries D.
 SEMINARS IN THROMBOSIS AND HEMOSTASIS: 2015; 41: S. 61-67

Point-of-Care Testing in Critically Ill Patients
 Fries, Dietmar, Streif, Werner,
 SEMINARS IN THROMBOSIS AND HEMOSTASIS: 2015; 41: S. 75-83

Fibrinogen concentrate improves clot strength in patients with haematological malignancies requiring platelet transfusion
 Munk-Andersen, H., Schenk, B., Larsen, O. H., Fries, D., Fenger-Eriksen, C.,
 TRANSFUSION MEDICINE: 2016; 26: S. 291-296

Selected Funding

In 2016 we were able to obtain a grand total of € 933,497.03 through funding. In other words, a part of this money was received in 2016 from previous contracts or stipulated in contracts signed during the current year (for 2016 and following years). Moreover, we are going to finalize contracts over € 300,000 for clinical studies and over € 80,000 for experimental projects in the near future.

Collaborations

- Univ.-Prof. Dr. Dirk Meyer, Molekulare Genetik und Entwicklungsbiologie, Naturwissenschaftliche Universität, Innsbruck, Österreich
- Prof. Dr. med. Christian F. Weber, Oberarzt, Klinik für Anästhesiologie, Intensivmedizin und Schmerztherapie, Universitätsklinikum Frankfurt, Theodor-Stern-Kai 7, 60590 Frankfurt am Main
- Tel HashomerMedical University of TelAviv, Israel
- US Army, Fort Sam Houton, Texas, USA
- Dept. of Bioengineering, Univ. of San Diego, USA
- Dept. for Anesthesia, Aarhus, Denmark
- Dept. for Hematology, Kings College London, UK
- Dept. for Trauma Surgery, Cologne Merheim Medical Center, Germany

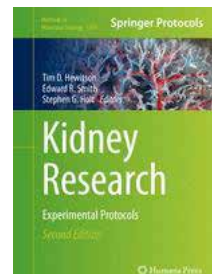

*Kidney Research
 Methods in Molecular Biology
 Biopsychronology: A Method Using Live
 Tissue Staining to Image Cell Function in
 the Kidney.
 Ashraf MI, Fries D, Streif W, Aigner F,
 Hengster P, Troppmair J, Hermann M.
 Methods Mol Biol. 2016;1397:81-90.*



*Transfusionsassoziierte Pharmakotherapie.
 Fibrinogen (FI)
 Dietmar Fries, Mirjam Bachler, Martin
 Hermann. Springerverlag.*

Internal Medicine I



Director:
Univ.-Prof. Dr. Herbert Tilg

Contact:
Anichstraße 35
6020 Innsbruck

Herbert.Tilg@i-med.ac.at
Phone: +43 512 504 23539
Fax: +43 512 504 23538
<http://inneremed1.tirol-kliniken.at>

Research Branch (ÖSTAT Classification)

301904, 302012, 302014,
302016, 302025

Keywords

Gastroenterology, endocrinology, metabolism, inflammation, hepatology, nutrition, non-alcoholic fatty liver disease, inflammatory bowel disease

Research Focus

The research of our department is focused on translational research in the fields of gastroenterology, endocrinology, metabolism and hepatology and is represented by several research groups. The overall objective of our scientific activities is to gain better insights into pathophysiology of prevalent diseases such as inflammatory bowel disease, non-alcoholic fatty liver disease, obesity, type 2 diabetes and atherosclerosis. Better knowledge will help to improve clinical management of these patients in the future.

The major research topics are:

- The cause and effects of intestinal inflammation particularly in connection with diseases like Crohn's disease and ulcerative colitis

- The role of inflammation and metabolism in development of non-alcoholic fatty liver disease
- Molecular effects of environmental factors in obesity and insulin resistance and the interaction of several organs or tissues in metabolic disease
- Bariatric surgery and metabolic or immunological effects on the host
- Lipoprotein metabolism and atherosclerosis

General Facts

The Department of Internal Medicine I has its focus in the specific medical areas of gastroenterology, endocrinology, metabolism and hepatology. Our division has about 40 employees and many members are involved both in clinical work and research. Our laboratories are perfectly equipped and our researchers are able to perform state-of-the-art research in the field of cellular and molecular work. The common aim of our research activities is to increase knowledge in the respective disease areas and to improve patient care. We have established different national and international collaborations throughout the world. Our research has been funded by the Austrian Research Promotion Agency (FFG), Austrian Science Fund (FWF), Christian Doppler Forschungs-

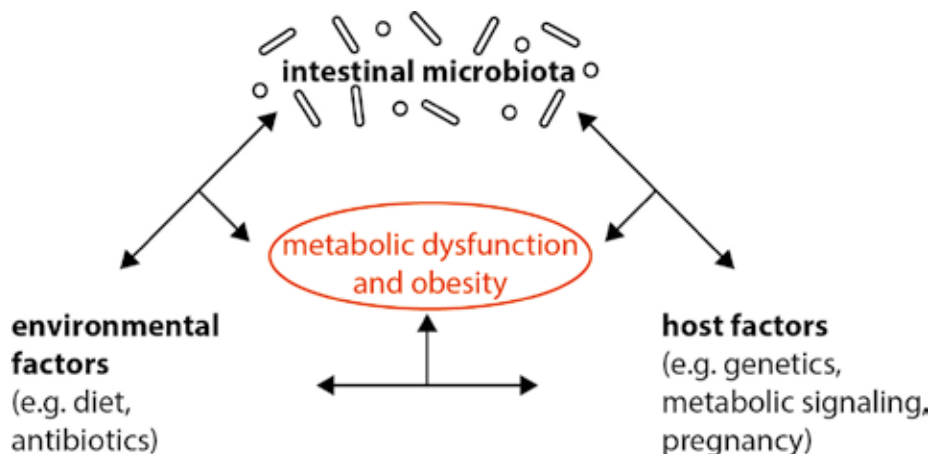

Fig. 1: Pathophysiology of NAFLD and the metabolic syndrome. Recent studies revealed a substantial contribution of the microbiota for metabolic diseases. The current model suggests that environmental factors (e.g. dietary factors, antibiotic treatment) and host-derived factors (e.g. genetics, metabolic signalling, pregnancy) are closely communicating with the resident microbiota. Vice versa, the presence of a (healthy) commensal microbiota affects metabolic signalling of the host (e.g. FIAF (fasting-induced adipocyte factor), AMPK (AMP-activated protein kinase)), similar to bacterial digestion of dietary end-products (e.g. short chain fatty acids). It emerges that alterations in microbial structure and function modulate the penetrance of metabolic dysfunction and obesity. The origin of microbial derangements in metabolic diseases remains largely enigmatic but may involve antibiotic treatment early in life, dietary changes and host genetics. Adapted from (Tilg and Adolph, 2015).



Fig. 2: Proposed mechanism ALD and mode of action of IL-8 blockade by the pepducin x1/2pal-i1 therapy. Ethanol-associated cytotoxicity induces hepatic expression of IL-8 which recruits neutrophils to instigate inflammation and mediate hepatic pathology through danger signals. Inhibition of IL-8 with pepducin x1/2pal-i1 may protect against ALD by inhibition of detrimental inflammatory cascades. IL, interleukin; MMP, matrix metalloproteinases; MPO, myeloperoxidase; ROS, reactive oxygen species; TNF, tumour necrosis factor. Adapted from Wieser V *et al*, *Gut*, 2016.

gesellschaft (CDG), European Union (FP7) for several years now and we have published our research in highly respected international Journals such as *Nature Communications*, *New England Journal of Medicine*, *Gut*, *Cell Host Microbe*, *Gastroenterology* and many others.

Research

Hepatology

The research group has an interest in liver diseases and in the closely related metabolic syndrome and focuses on investigating disease mechanisms in non-alcoholic fatty liver disease (NAFLD) and alcoholic liver disease (ALD), respectively (Figure 1). The world health organisation noted a steep rise of these disease entities for which treatment modalities are desperately needed. Thus, in order to establish treatment modalities, we investigate how inflammation modulates the susceptibility to NAFLD and ALD; inflammation has been implicated in liver diseases for more than 20 years. Recently, we have published work that revealed an impact of hepatic type I interferon signalling in the development of NAFLD and the metabolic syndrome (Wieser V *et al.*, *Gut*, 2016). Furthermore, we unravelled that a siderophore that regulates iron homeostasis promotes ALD by regulating

neutrophilic inflammation (Wieser V *et al.*, *J Hepatol*, 2015). Therapeutically, we have established that neutrophilic inflammation and ALD can be reversed through selective blockade of IL-8 (Figure 2) (Wieser V *et al.*, *Gut*, 2016). As the microbiota is critically involved in regulation of hepatic diseases (Tilg & Adolph, *Curr Opin Pediatr*, 2015), we are currently studying the impact of specific bacterial strains on the susceptibility to developing ALD. These studies may be informative to translate basic research findings into novel therapeutic approaches.

Endocrinology and Metabolism Insulin Resistance

Insulin resistance is a hallmark of type 2 diabetes and is highly prevalent in obesity. In our research group we are especially interested in defining tissue-specific molecular effects of various diets including ones with high fructose, sucrose and/or fat content. Furthermore, we aim to characterize cellular effects of incretin hormones in more detail. In an animal model of diet-induced insulin resistance we were able to show that dietary components have tremendous effects on whitening of adipocytes and adipose tissue inflammation. Parts of these results were presented at the 4th Helmholtz-Nature Medicine Diabetes Conference. Another focus of our work is to better un-

derstand the close interaction between various organs or tissues in obesity and insulin resistance. We are especially interested in investigating the crosstalk between adipose tissue and the liver. By secreting adipocytokines and inflammatory cytokines and also by releasing fatty acids, the adipose tissue critically determines hepatic triglyceride accumulation in states of insulin resistance resulting clinically in non-alcoholic fatty liver disease. On the other hand fat accumulation in the liver further diminishes hepatic insulin sensitivity by interfering with the insulin signalling pathway (Figure 3).

Another focus of our research is to characterize endocrine alterations in obesity. Currently, we are especially interested in defining metabolic effects of growth hormone in metabolically highly active tissues in order to better understand the clinical significance of low growth hormone action in obesity.

Bariatric Surgery

Bariatric surgery is an ideal model to study the effects of sustained weight reduction. In several papers our groups were able to show that pronounced weight reduction is associated with improvements of inflammation, cardiovascular surrogate markers and important parameters of glucose or lipid ho-

meostasis. In a recent work we found that tissue expression of heme-oxygenase-1, a key enzyme in heme catabolism which has also been linked to the pathogenesis of diet-induced insulin resistance and inflammation, significantly decreases with weight loss after bariatric surgery (Ress C *et al.*, Diabet Med, 2017). In other work relative telomere length was found to be increased after bariatric surgery in the long term, presumably due to amelioration of metabolic traits. These findings further emphasize beneficial pleiotropic effects of significant weight loss in obese patients (Laimer M *et al.*, Int J Obes, 2016).

Atherosclerosis

Many epidemiological studies have shown that low HDL-cholesterol levels are associated with high cardiovascular risk. However, in some interventional studies therapeutic increases of HDL-cholesterol were not associated with reductions of cardiovascular risk, challenging the hypothesis

that HDL-cholesterol is causally involved in pathogenesis of cardiovascular disease. HDL particles are well known for their function in reverse cholesterol transport (März W, Ritsch A J Am Coll Cardiol, 2016). The focus of our research is to investigate pleiotropic functions of HDL particles. Currently, we aim to define determinants of cholesterol efflux in human endothelial cells and macrophages and to better characterize regulatory mechanisms of key enzymes or proteins in reverse cholesterol transport in animal models of atherosclerosis. In a clinical study, we work on determination of HDL particle activity in patients at very high cardiovascular risk.

Gastroenterology

Intestinal inflammation constitutes another central research focus of our Department, both clinically and experimentally. Recent advances in sequencing technologies opened up the possibility to study the extremely exciting field of the intestinal micro-

biome, our commensal bacteria and their metabolic properties, and how this “organ within an organ” affects human physiology both in homeostasis and in disease. On the one hand we are interested in how exogenous environmental signals such as nutrient factors are integrated via the microbiome into communication pathways with the host. On the other hand we are looking for host factors that in turn are capable of shaping gut community compositions. In this context we were able to identify a host factor called Lipocalin 2 (Lcn2) potentially shaping intestinal bacterial structures during intestinal inflammation. We could show that Lcn2 deficiency was not associated with increased intestinal inflammation in experimental colitis but that lack of Lcn2 resulted in the spontaneous development of intestinal tumors. This has significant translational relevance since colitis-associated cancer represents a redoubtable complication of human inflammatory bowel diseases. Furthermore, we were able to show that

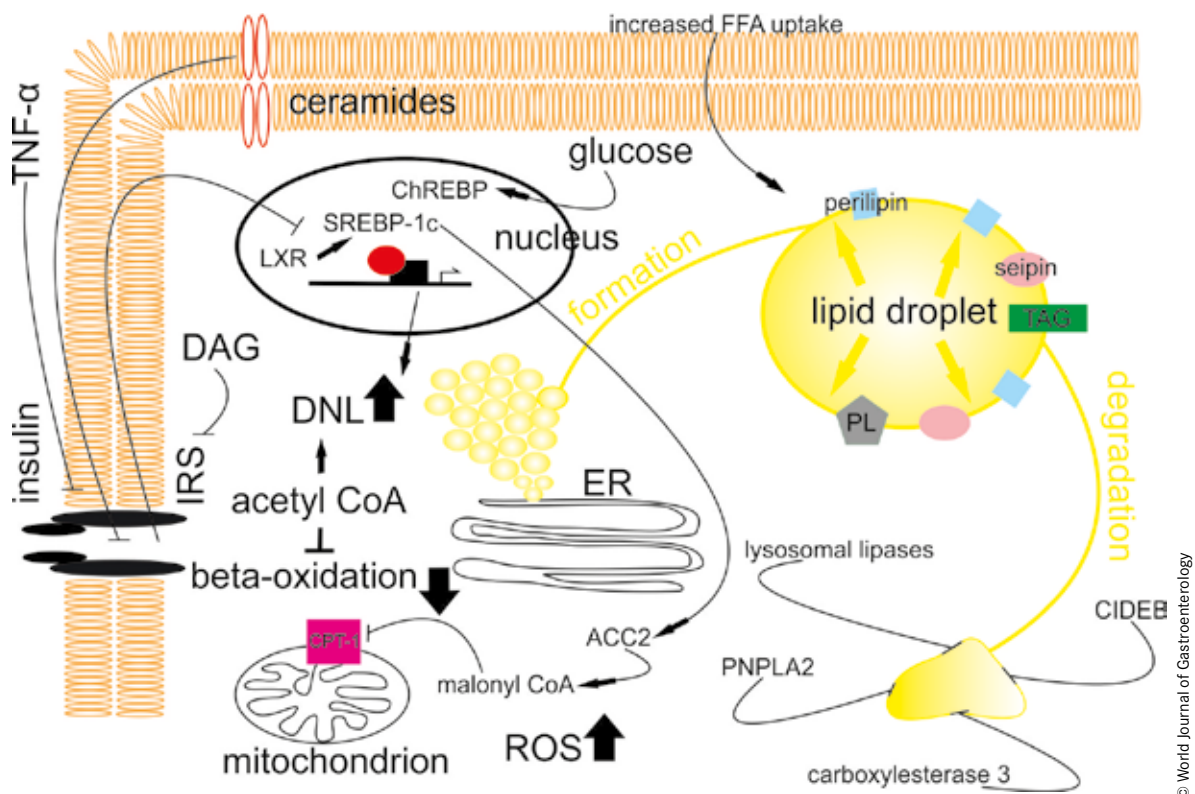

Fig. 3: Figure 3 shows the close interaction between systemic glucose metabolism and hepatic fatty acid metabolism. In states of insulin resistance high concentrations of circulating free fatty acids and proinflammatory cytokines promote hepatic triglyceride accumulation. Vice versa intermediates of long chain fatty acids inhibit insulin signaling in hepatocytes, further diminishing hepatic insulin sensitivity. DNL, de novo lipogenesis; ACC; Acetyl CoA carboxylase, ER, endoplasmic reticulum, ; DAG, diacylglycerol; IRS, insulin receptor substrate; LXR, ligand-activated transcription factor; SREBP, sterol regulating element binding protein, CPT-1, carnitine palmitoyl transferase 1; LD, lipid droplet; ATGL, adipose triglyceride lipase; CIDEB, cell death inducing DFFA like effector B; ChREBP, Carbohydrate response element; ROS, reactive oxygen species; PNPLA2 patatin-like phospholipase domain-containing protein2. Adapted from Ress & Kaser. World Journal Gastroenterology, 2016

both inflammation and tumor development depended on an altered microbial composition triggered by Lcn2 deficiency. Strikingly, we were able to identify *Alistipes* spp. as a culprit species indeed driving both inflammation and tumorigenesis. Notably, we also found *Alistipes* in human patients with spontaneous colorectal cancer. We were able to publish our research in highly respected international Journals such as *Cell Host & Microbe* and *Nature* communications. Current studies in our laboratory are focusing on additional mechanistic underpinnings of Lcn2-microbiome interactions and *Alistipes*-dependent inflammation and tumorigenesis.

Clinically, we are currently involved in several Phase 2 and 3 trials such as the SMAD7 antisense oligonucleotide Mongersen in Crohn's disease, the JAK1 inhibitor Filgotinib in Crohn's disease and ulcerative colitis, and the LY3074828 a humanized anti-p19 IgG4 antibody that blocks interleukin 23 in Crohn's disease. Contribution to these international multicenter trials enables us to offer desperately needed treatment options to our patients and to contribute to the improvement of clinical management of patients with inflammatory bowel diseases in general.

Selected Publications

Reversal of murine alcoholic steatohepatitis by pepducin-based functional blockade of interleukin-8 receptors

Wieser V, Adolph TE, Enrich B, Kuliopulos A, Kaser A, Tilg H, Kaneider NC
Gut. 2016 Feb 8. pii: gutjnl-2015-310344. doi: 10.1136/gutjnl-2015-310344.

Lipocalin 2 Protects from Inflammation and Tumorigenesis Associated with Gut Microbiota Alterations

Moschen AR, Gerner RR, Wang J, Klepsch V, Adolph TE, Reider SJ, Hackl H, Pfister A, Schilling J, Moser PL, Kempster SL, Swidsinski A, Orth Höller D, Weiss G, Baines JF, Kaser A, Tilg H.
Cell Host & MICROBE: 2016; 19: S. 455-69.

Lipocalin 2 drives neutrophilic inflammation in alcoholic liver disease

Wieser V, Tymoszyk P, Adolph TE, Grander C, Grabherr F, Enrich B, Pfister A, Lichtmanegger L, Gerner R, Drach M, Moser P, Zoller H, Weiss G, Moschen AR, Theurl I, Tilg H.
JOURNAL OF HEPATOLOGY: 2016; 64: S. 872-80

Gut microbiome development along the colorectal adenoma-carcinoma sequence

Feng Q, Liang S, Jia H, Stadlmayr A, Tang L, Lan Z, Zhang D, Xia H, Xu X, Jie Z, Su L, Li X, Li X, Li J, Xiao L, Huber-Schönauer U, Niederseer D, Xu X, Al-Aama JY, Yang H, Wang J, Kristiansen K, Arumugam M, Tilg H, Datz C, Wang J.
Nature Communication: 2015; 11: 6528.

Selected Funding

- Christian Doppler Research Laboratory for metabolic crosstalk, Christian Doppler Research Association (CDG), Euro 770,000, 2015-2021, Assoz Prof. Priv Doz. Dr. Susanne Kaser
- Epithelial glutathione peroxidase 4 in the control of intestinal homeostasis, Austrian Science Fund (FWF), Euro 331,758.00, 2016-2018, Dr. Timon Adolph, PhD
- VASCage – Research Center of Excellence in Vascular Ageing, Austrian Research Promotion Agency (FFG), COMET, Euro 360,000.00 2014-2018; Univ. Prof. Dr. Herbert Tilg
- HDL function and atherosclerosis: Studies in apolipoprotein E knockout rabbits, Austrian Science Fund (FWF), Euro 231,689.20 Euro, 2015-2018, ao Univ. Prof. Mag. Dr. Andreas Ritsch
- Long-term effects of weight loss on atherosclerosis, Austrian Science Fund (FWF), Euro 177,408.00, 2014-2016; ao Univ. Prof. Dr. Christoph Ebenbichler

Collaborations

- Charles A. Dinarello, Denver, Colorado, USA
- Georg Schett, Erlangen, Germany
- Stefan Schreiber, Kiel, Germany
- Arthur Kaser, Cambridge, UK
- Fredrik Bäckhed, Gothenburg, Sweden
- Patrice Cani, Brussels, Belgium
- Willem de Vos Wageningen, The Netherlands
- Roberto Vettor, Verona, Italy
- Javier Crespo, Santander, Spain
- Winfried März, Freiburg, Germany
- Arnold von Eckardstein, Zurich, Switzerland
- Zsuzsanne Bosze, Gödöllő, Hungary

Internal Medicine II



Director:
Univ.-Prof. Dr. Günter Weiss

Contact:
Anichstraße 35
6020 Innsbruck

Guenther.Weiss@i-med.ac.at
Phone: +43 512 504 23251
Fax: +43 512 504 23317
<https://inneremed2.tirol-kliniken.at>

Research Branch (ÖSTAT Classification)

302030, 301902, 302072, 303031

Keywords

Internal medicine, infectious diseases, immunology, rheumatology, pneumology, host-pathogen interaction, metal and lipid metabolism, anemia research, immune mediated diseases, immune deficiency, tropical medicine

Research Focus

Based on the broad clinical expertise at our department the research at our institution covers many different aspects of basic research and clinically relevant topics in infectious diseases, immunology, rheumatology and pneumology, both at the level of laboratory based science and clinical research including clinical studies with a major aim to translate the results of our scientific investigations from bench to bedside for the benefit of our patients.

General Facts

Apart from all aspects of general internal medicine our institution has a focus and core expertise in infectious disease, clinical immunology, rheumatology and pneumology, thus being the reference center for Western Austria in some of these medical

fields. As there is significant clinical and scientific overlap between these medical disciplines the combined expertise at our department creates a positive synergy and gain of knowledge for optimized treatment of patients and in performing clinical and laboratory based research. Our department consists of three inpatient wards, and three outpatients clinics with a focus on infectious disease/immunology and tropical medicine, on rheumatology and on pneumology, respectively. Apart from routine investigations of internal medicine, we also perform laboratory diagnostics of infectious diseases, tropical infections, auto-immune disorders and immunodeficiency as well as functional pulmonary analyses along with bronchoscopy. A study center coordinates the clinical studies at our institution.

Several research groups investigate relevant topics in our fields of interest as detailed below, making use of up-to-date laboratory technologies of biochemistry, molecular biology, cell biology, immunology, microbiology and genetics both *in vitro* and *in vivo*. Our laboratories are well equipped with modern infrastructure including high throughput PCR, a FACS analyzer or an *in vivo* fluorescence imager.

A major goal of our institution is also devoted to high quality education in clinics and science, to provide an excellent environment for international competitive research

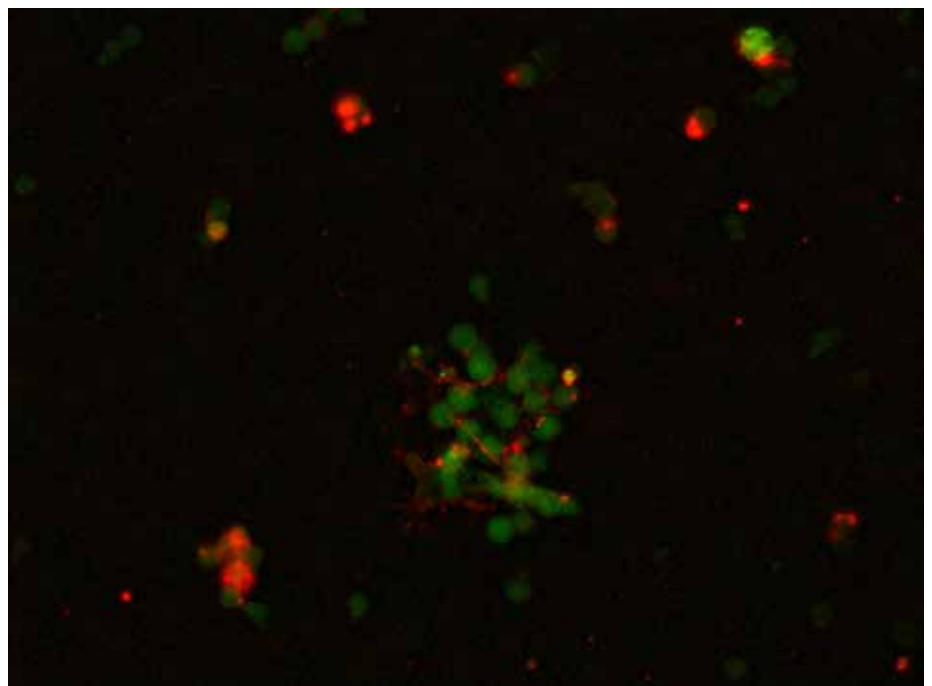

Fig. 1: Erythroide niche: Erythroblasts (Ter119 FITC-green) and nursing macrophage (CD169 Cy3-red)

in the laboratory and at the bedside, and to inspire medical doctors to combine research with their clinical occupation and to critically evaluate the clinical practice and the available information.

Research

Research in Molecular Immunology and Infectious Diseases

In our recent studies, we have characterized the roles of three candidate genes in the course of *Salmonella Typhimurium* infection. All three gene products (i.e. iron regulatory proteins-1 and -2, lipocalin-2 and heme oxygenase-1) are expressed in myeloid cells and are involved in macrophage iron handling and immune response.

Iron regulatory proteins (IRPs) orchestrate cellular iron homeostasis by posttranscriptional mechanisms. In collaboration with Bruno Galy and Matthias W. Hentze (EMBL, Heidelberg), we have seen that mice lacking both IRP-1 and IRP-2 in the myeloid compartment have increased ferritin expression in macrophages, which translates into higher serum ferritin levels. While these mice have normal erythropoiesis and unimpaired iron recycling from aged red blood cells, they are susceptible to infection with the iron-dependent bacterium *Salmonella Typhimurium*. Mechanistically, IRPs restrict the ferritin-associated iron pool in macrophages thus limiting the availability of iron for intracellular *Salmonella*. Moreover, IRPs stimulate the production of tumor necrosis factor, interleukin-6 and of lipocalin-2 by macrophages, thus contributing to improved bacterial killing.

Heme oxygenase-1 (Hmox-1) catalyzes the degradation of heme, a process central to the recycling of iron from aged red blood cells. Since Hmox-1 is up-regulated in response to *Salmonella* infection, we investigated a putative immune-modulatory role of Hmox-1. The results obtained showed that the early induction of Hmox-1 during the course of *Salmonella* infection is detrimental to the innate immune response. Inducible knock-down of Hmox-1 in macrophages resulted in improved bacterial killing attributable to increased production of tumor necrosis factor and of anti-bacterial reactive oxygen species. Therefore, Hmox-1 inhibition may be an adjunct therapy in the setting of *Salmonella Typhimurium* infection. Lipocalin-2 (Lcn-2) is an innate immune peptide with pleiotropic effects. For instance, it stimulates the chemotaxis of neutrophils and neutralizes bacterial siderophores. Siderophores are small iron chelators

secreted by many bacterial species and some fungi to supply iron for metabolism and proliferation. We have seen that Lcn-2 has an additional immune-regulatory property: Lcn-2 represses IL-10 thus licensing high-output production of tumor necrosis factor, interleukin-6 and reactive nitrogen species.

Further, we could demonstrate that the cellular localisation of the intracellular bacterium, *Listeria monocytogenes*, determines its dependence on iron availability and the orchestration of immune effector pathways including the restriction of iron availability. In summary, the maintenance of macrophage iron homeostasis and innate immune effector functions are intimately linked. This is illustrated by the fact that IRPs, Hmox-1 and Lcn-2 fulfil central tasks at the intersection of these pathways.

Anemia Research

A central research focus of this clinic is to study the pathophysiology of anemia of chronic disease (ACD) and to identify new potential new treatment options.

In the general Western population, anemia of chronic disease (ACD), also termed anemia of inflammation (AI), is the most frequent entity in hospitalized patients, occurring in subjects with diseases involving chronic immune activation (such as patients with auto-immune diseases, infection and cancer, but also in subjects with chronic kidney disease, congestive heart failure or obesity).

The underlying causes are multifactorial and include an impaired biological activity of the red cell hormone erythropoietin but also anti-proliferative effects of different cytokines, like TNF- α and interleukin-1, towards the proliferation and differentiation of erythroid progenitor cells. Most importantly, an immunity driven diversion of cellular and systemic iron trafficking results in iron retention within cells of the reticuloendothelial system and thus in an iron restricted erythropoiesis. Novel treatment strategies are based on our expanding knowledge on the mechanisms underlying these pathologic processes. The iron hormone hepcidin as well as several cytokines are involved in macrophage iron retention. Pharmacologic inhibition of hepcidin activity was previously shown by us and others to increase the iron delivery from macrophages and to reverse anemia, a novel therapeutic principle which is now being tested in clinical phase I and II trials. Macrophages also play a critical role

for the maintenance of iron homeostasis because they take up senescent erythrocytes and re-utilize iron. Accordingly, in various pathophysiological conditions, where erythrocyte life span is compromised and hemolysis can occur, macrophages expand their erythrophagocytotic capacity to avoid tissue damage via the radical promoting activity from erythrocyte-derived heme. Recently, we identified an on-demand mechanism that clears erythrocytes and recycles iron (Theurl *et al.* *Nature Medicine* 2016). We showed that monocytes that express high levels of lymphocyte antigen 6 complex, locus C1 (LY6C1, also known as Ly-6C) ingest stressed and senescent erythrocytes, accumulate in the liver via coordinated chemotactic cues, and differentiate into ferroportin 1 (FPN1, encoded by SLC40A1)-expressing macrophages that can deliver iron to hepatocytes.

On the basis of these data we find it interesting that macrophage-derived factors such as S100A8/S100A9 directly affect erythroid differentiation in an inflammatory state. Moreover, erythroid niche macrophages have been shown to have a direct effect on erythroid differentiation in a thalassemia model in a yet not completely understood way.

Erythroid niche macrophages seem to nurse the developing erythroid cells with iron and/or other growth factors. However, the specific iron source provided by the erythroid niche macrophages and the whole set of growth factors provided by these cells are far from being understood. As understanding of these mechanisms may have high potential for the development of new therapeutic approaches for treatment of ACD we are currently focusing our research in this area.

Research in Clinical Immunology and Clinical Infectious Diseases

Within the last two years we could gain new insights into the role of immune activation in patients with rheumatoid arthritis, COPD, HIV, and patients with solid tumors. In patients with rheumatoid arthritis we could demonstrate a relationship between elevated neopterin and osteoprotegerin levels before treatment with TNF-inhibitors. In patients with HIV we found a relationship between alterations in tryptophan and iron metabolism, furthermore the role of disturbed amino acid metabolism in the development of neuro-psychiatric symptoms was discussed in a review. In patients with cancer we investigated the relationship

between quality of life, depression and immune activation. The clinical studies were further focusing on identification of novel diagnostic parameters for respiratory infections and investigations toward on the potential benefit of physiotherapy in the treatment of pneumonia.

We could show different profiles of inflammatory parameters and neopterin for the differential diagnosis between community acquired pneumonia/CAP, COPD and CAP plus COPD and in seasonal influenza. In a prospective pilot study we found that sets and levels of volatile organic compounds/VOCs allow the discrimination between stable and exacerbated COPD (submitted). In another pilot study we could show that physiotherapy in the treatment of elderly patients with CAP improved the activities of daily life and duration of hospital stay (submitted).

Pneumological Research

Our pneumological research is focused on rare pulmonary diseases. The orphan lung diseases comprise many disorders such as pulmonary arterial hypertension (PAH), lung fibrosis, sarcoidosis and cystic lung diseases. All those patients are registered within a database and a biobank with biological specimen will be established. Ongoing projects concern patients with pulmonary arterial hypertension (PAH) representing the major cohort of patients, and efforts for improved screening within high risk populations (e.g. patients with connective tissue disease). Interestingly, systemic iron deficiency without anemia is frequent in patients with pulmonary arterial hypertension (PAH) (Figure 2). Whether this is an independent comorbidity or is causally related to the initiation or progression of PAH is still unknown.

Our translational research aims to understand the physiological control of systemic and cellular iron metabolism and its disturbances in PAH. By investigation of clinical phenotypes of a cohort of PAH patients and characterization of associated iron dyshomeostasis at serum and monocytes levels, including cytokines, growth factors and mitochondrial function signature further insights on iron metabolism will be gained.

Rheumatological Research
Our clinical rheumatological research is focused on the evaluation of a new referral tools for primary care physicians and specialists to our outpatient unit, diagnostic issues (with specific impact on sonography), validation of new classification criteria (e.g. for polymyalgia rheumatica and Behcet's disease) and outcome of rheumatic diseases (e.g. by supporting the international evaluation of the new ASAS-health index). Our current work on a structured

disease-specific clinical database together with a clinical biobank will further support translational research. Hyperuricaemia is a frequent clinical condition eventually resulting in gout. While local urate deposition results in activation of the immune system via the NALP3 inflammasome, hyperuricaemia also causes systemic metabolic effects, and increased circulating uric acid levels are a known risk factor for coronary heart diseases. In a fruitful collaboration with the clinics of radiology this association is investigated by the combination of state of the art ultrasound and computer tomography (DECT) imaging along with investigations of the effects of immune-modulatory drugs on the course of the disease *in vitro* and *in vivo*.

An ongoing clinical study currently investigates the prevalence and nature of anemia in systemic rheumatic diseases, its impact on disease activity, morbidity and mortality along with its modification by disease modifying drugs.

We conduct clinical trials in inflammatory bowel disease, viral hepatitis, biliary diseases, hepatocellular carcinoma or non-alcoholic liver disease. To ascertain the high quality requirements of good clinical practice our department employs two study coordinators, Mag. Toaba and Mag. Zotter.

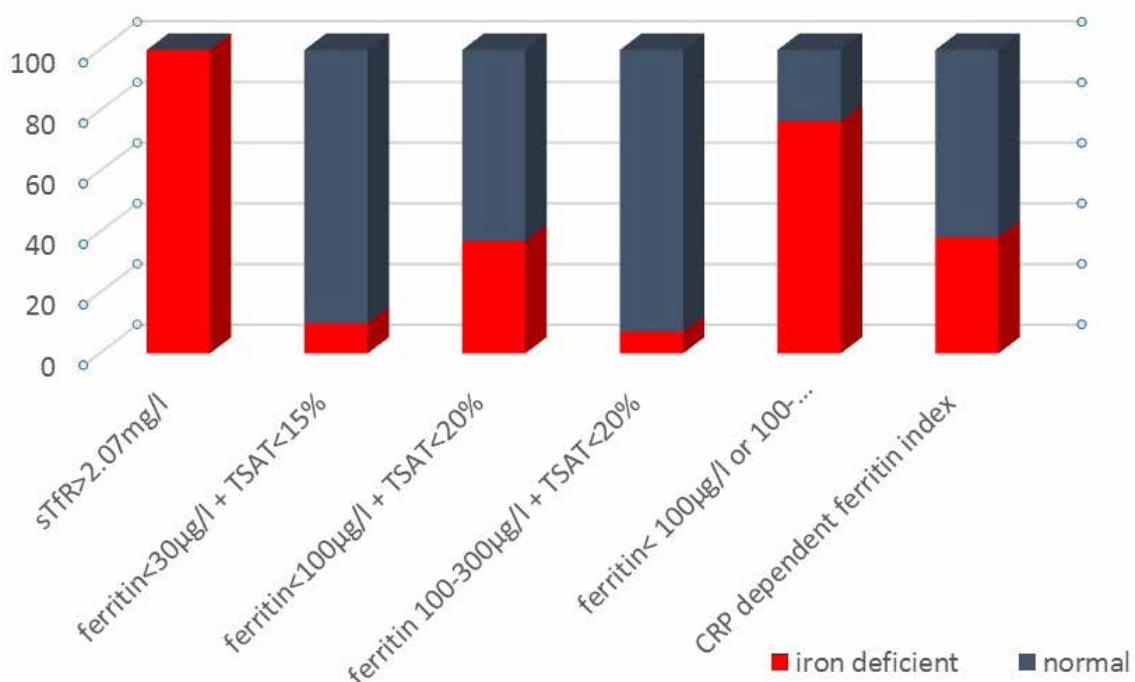

Fig. 2: Prevalence of iron deficiency (%) in 84 patients with PAH depending on the ID definition.

Selected Publications

On-demand erythrocyte disposal and iron recycling requires transient macrophages in the liver

Theurl I, Hilgendorf I, Nairz M, Tymoszyk P, Haschka D, Asshoff M, He S, Gerhardt LMS, Holderried TAW, Seifert M, Sopper S, Fenn AM, Anzai A, Rattik S, McAlpine C, Theurl M, Wieghofer P, Iwamoto Y, Weber GF, Harder NK, Chousterman BG, Arvedson TL, McKee M, Wang F, Lutz OMD, Rezoagli E, Babitt JL, Berra L, Prinz M, Nahrendorf M, Weiss G, Weissleder R, Lin HY, Swirski FK. NATURE MEDICINE: 2016; 22: S. 945-51.

Iron Regulatory Proteins Mediate Host Resistance to Salmonella Infection

Nairz M, Ferring-Appel D, Casarubea D, Sonnweber T, Viatte L, Schroll A, Haschka D, Fang FC, Hentze MW, Weiss G, Galy B. CELL HOST MICROBE: 2015; 18: S. 254-61
The Iron age of host-microbe interactions. Soares MP, Weiss G. EMBO REPORT: 2015; 16: S. 1482-500

Heme oxygenase 1 controls early innate immune response of macrophages to Salmonella Typhimurium infection

Mitterstiller AM, Haschka D, Dichtl S, Nairz M, Demetz E, Talasz H, Soares MP, Einwallner E, Esterbauer H, Fang FC, Geley S, Weiss G. CELL MICROBIOLOGY: 2016; 10: S. 1374-89

Macrophage defense mechanisms against intracellular bacteria

Weiss G, Schaible UE. IMMUNOLOGICAL REVIEWS: 2015; 264: S. 182-203

Lipocalin-2 ensures host defense against Salmonella Typhimurium by controlling macrophage iron homeostasis and immune response

Nairz M, Schroll A, Haschka D, Dichtl S, Sonnweber T, Theurl I, Theurl M, Lindner E, Demetz E, Abhoff M, Bellmann-Weiler R, Müller R, Gerner RR, Moschen AR, Baumgartner N, Moser PL, Talasz H, Tilg H, Fang FC, Weiss G. EUROPEAN JOURNAL OF IMMUNOLOGY: 2015; 45: S. 3073-3086

Patients suffering from axial spondyloarthritis (aSpA) show an age-inappropriate shrinkage of thymic output, shortening of telomere lengths and an impaired telomerase enzyme as hallmark features of premature immunosenescence

Fessler J, Raicht A, Husic R, Ficjan A, Duftner C, Schwinger W, Dejaco C, Schirmer M. Premature senescence of T-cell subsets in axial spondyloarthritis. ANNALS OF THE RHEUMATIC DISEASES: 2016; 75: S. 748-54.

Recommendations informing clinicians about best practices in the care of patients with PMR

Dejaco C, Singh YP, Perel P, Hutchings A, Camellino D, Mackie S, Abril A, Bacht A, Balint P, Barraclough K, Bianconi L, Buttgerit F, Carsons S, Ching D, Cid M, Cimmino M, Diamantopoulos A, Docken W, Duftner C, Fashanu B, Gilbert K, Hildreth P, Hollywood J, Jayne D, Lima M, Maharaj A, Mallen C, Martinez-Taboada V, Maz M, Merry S, Miller J, Mori S, Neill L, Nordborg E, Nott J, Padbury H, Pease C, Salvarani C, Schirmer M, Schmidt W, Spiera R, Tronnier D, Wagner A, Whitlock M, Matteson EL, Dasgupta B. 2015 ANNALS OF THE RHEUMATIC DISEASES: 2015; 74: S. 1799-807

Effects of Antitumor Necrosis Factor Therapy on Osteoprotegerin, Neopterin, and sRANKL Concentrations in Patients with Rheumatoid Arthritis

Kurz, Katharina, Herold, Manfred, Russe, Elisabeth, Klotz, Werner, Weiss, Guenter, Fuchs, Dietmar. DISEASE MARKERS: 2015; : S. 276969

Selected Funding

- ERA-INFECT -Epigenetic basis and therapeutic implications of the cross-regulation of arginase 1 and inducible nitric oxide synthase in chronic leishmaniasis and salmonellosis-- G. Weiss
- FWF (TAM Eisenmetabolismus in der Progression von Brustkrebs) - I. Theurl
- Nationalbankprojekt (Jubiläumsfondsprojekt Nr. 17271 "Klinische und translationale Untersuchung der Eisen Dyshomöostase bei Patienten mit Lungenhochdruck") - J. Löffler

Collaborations

- Christian Bogdan, Mikrobiologisches Institut - Klinische Mikrobiologie, Immunologie und Hygiene, Universitätsklinikum Erlangen and Friedrich-Alexander Universität (FAU) Erlangen-Nürnberg, Erlangen, Germany
- Thomas Decker, Max Perutz Laboratory, Dr. Bohr-Gasse 9, 1030 Vienna Vienna
- Jonathan Jantsch, Institut für Klinische Mikrobiologie und Hygiene, Universitätsklinikum Regensburg, 93053 Regensburg
- Martina U. Muckenthaler, Bruno Galy and Matthias W. Hentze, Molecular Medicine Partnership Unit, European Molecular Biology Laboratory and University of Heidelberg, Heidelberg, Germany
- Ferric C. Fang, Department of Laboratory Medicine, University of Washington, Seattle, WA, USA
- Filip Swirski, Center for Systems Biology, Massachusetts General Hospital, Boston

Internal Medicine III



Director (interim):
Univ.-Prof. Dr. Günter Weiss

Contact:
Anichstraße 35
6020 Innsbruck

Guenther.Weiss@i-med.ac.at
Phone: +43-512-504-23251
Fax: +43-512-504-23317
<http://inneremed3.tirol-kliniken.at/>

Research Branch (ÖSTAT Classification)

302006, 302030, 302032

Keywords

Atherosclerosis, angiogenesis, cardiac magnetic resonance tomography, cardiovascular regeneration, aging, bio-marker

Research Focus

The focus of our cardiovascular research group is based on 3 complementing columns to develop novel therapies for cardiac and vascular regeneration as well as the implementation of new imaging methods and translational research to the clinic:

Column 1: Cardiac Regeneration and Aging: The aim is to develop novel therapies to build new heart tissue and vessels.

Column 2: The major goal is to utilize novel imaging technologies like MSCT or MRT to monitor and improve clinical therapies.

Column 3: Monitoring of international phase 2-3 Clinical studies.

General Facts

In the department of Cardiology and Angiology research is structured into several groups with distinct research focusses ranging from translational research on cardiovascular regeneration, atherosclerosis and angiogenesis to clinical research focussing on cardiac magnetic resonance tomography. The group of Doz. Brenner works on cardiovascular regeneration and stem cell therapy. Related research is conducted by Doz. Zaruba and his group who also work on cardiac regeneration and aging. Doz. Zaruba recently received an FWF grant as outlined below. Prof. Metzler works on cardiac imaging by MRI especially related to acute coronary syndroms. The group of Prof. Mair works on cardiac biomarkers and clinical implications. The group of Prof. Kirchmair and Dr. Theurl is doing research on vascular biology and angiogenesis. They described novel angiogenic factors, the neuropeptides catestatin and secretoneurin. Dr. Theurl received an FWF grant also outlined below.

Research

Cardiac Magnetic Resonance Tomography

Leader: Univ.-Prof. Dr. Bernhard Metzler, MSc, FESC

Members: Assoz.-Prof. PD Dr. G. Klug

*(Cardiology),
Ass.-Prof. Dr. A. Mayr (Radiology),
Dr. H-J. Feistritzer, PhD (Cardiology),
Dr. S. J. Reinstadler, PhD (Cardiology),
Dr. M. Reindl, PhD Student (Cardiology),
Dr. L. Nieß, PhD Student (Cardiology),
Currently 9 medical Diploma Students*

Summary:

The Working Group „Cardiac Magnetic Resonance Tomography (CMR)“ of Prof. Dr. B. Metzler, MSc was founded in 2002 and published over 50 peer reviewed publications since then. Their main focus is CMR in patients with ST-segment elevation myocardial infarction (STEMI), cardiac metabolic magnetic resonance spectroscopy and the development of novel clinical applications of phase-contrast CMR and MR-angiography in patients with aortic stenosis.

The working group is based on a close cooperation between the University Clinic of Internal Medicine III, Cardiology and Angiology (Head: Prof. Dr. G. Weiss) and the Department of Radiology (Head: Prof. W. Jaschke) at the Medical University of Innsbruck. The team of Prof. Metzler consists of two associate professors, two fellows with a clinical PhD and two PhD-Students as well as currently 9 diploma students.

In 2015 and 2016 the working group published 17 peer reviewed original research articles and obtained six research grants. International cooperation with the CMR working groups of Prof. H. Arheden at the University Lund, Sweden and Prof. Dr. H. Thiele at the University Lübeck, Germany, with another seven publications, were initiated. Future aims are to establish extended cooperation with centres in Austria to perform multi-centre CMR studies.

Cardiovascular Regeneration and Aging

Leader: Ass.-Prof. PD Dr. Marc-Michael Zaruba

Group members: Ass.-Prof. M.M. Zaruba, S.K. Ghadge (PhD), M. Messner (PhD student)

Research Topics:

I. Cell specific role of SDF-1 (Stromal cell-derived factor 1) in the recruitment of progenitor cells after myocardial ischemia (FWF P28817-B28).

Ongoing research suggests a fundamental role of the SDF-1/CXCR4 (CXC-Motiv-chemokine receptor 4; SDF-1 receptor) axis in cardiac repair and tissue homeostasis after ischemia. Recently, we could demonstrate that genetic and pharmacolog-

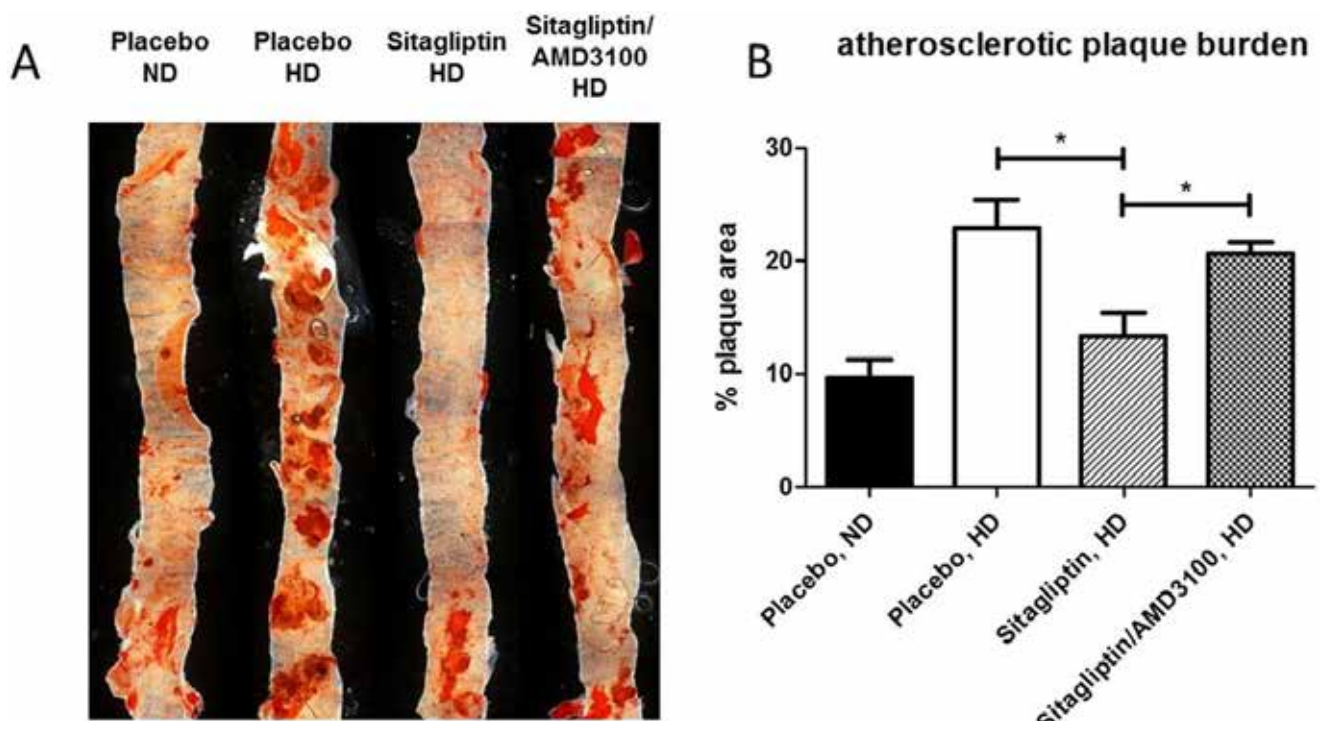

Fig. 1: Feeding with high cholesterol diet (HD) leads to a significant increase of atherosclerotic plaques in the aorta of placebo treated mice as compared to animals on a normal diet (ND). The addition of the DPP4 inhibitor Sitagliptin reduced the development of atherosclerotic plaques and high cholesterol diet whereas the CXCR4 blocker AMD3100 abolished the Sitagliptin-mediate protective effect.

ical inhibition of (SDF-1) degradation after myocardial infarction (MI) prevents adverse cardiac remodelling and may even enhance cardiac regeneration. Nevertheless, the precise cellular mechanisms how SDF-1 dependent cell migration is orchestrated remain barely understood. In our current FWF funded project we aim to identify important cellular sources for SDF-1 dependent cell recruitment and cardiac repair.

We first aim to investigate the cell specific effects of SDF-1 ablation in smooth muscle cells and pericytes with respect to myocardial CXCR4+ cell recruitment and cardiac repair utilizing conditional SDF-1 specific knockout mouse models. Further studies are designed to elucidate the therapeutic potential of HIF (hypoxia-inducible factor)-prolylhydroxylase inhibitors (PHI) to induce SDF-1 gene expression and stimulate cardiac repair in the ischemic heart.

Ultimately, these approaches might be very useful to develop novel therapies to augment myocardial repair mechanisms or even reconstitute myocardial mass following cardiac injury. Our preliminary data suggest that inhibition of prolyl hydroxylase may be a promising target for HIF-1 α mediated SDF-1 activation to increase stem cell

homing and myocardial repair.

Future Goals:

- 1.) Lineage tracing of regenerative cell populations in the neonatal and adult heart to develop new therapies for severe heart failure.
- 2.) Elucidating the role of aging-related enzymes in the development and progression of heart failure.

II. Aging related splicing variants in patients with cardiomyopathy

Ass.-Prof. M.M. Zaruba,
S.K. Ghadge (PhD),
M. Messner (PhD student)

Defined mutations in the human lamin A gene or in enzymes processing the important nuclear membrane protein LMNA (e.g. Zmpste24) are causally involved in premature aging syndromes like progeria. Patients suffering from progeria develop severe cardiovascular morbidities like stroke, myocardial infarction, and severe atherosclerosis leading to early death.

We are currently using this model to investigate new targets that can inhibit this aging process. In the current projects we investigate whether premature aging enzymes, such as LMNA, play a role in the develop-

ment of heart failure.

Cardiovascular Regeneration

Leader: Priv.Do. Dr. med. Christoph Brenner
Cardiovascular diseases are the most frequent cause of death in Europe. None of the presently available options for the treatment of atherosclerosis has been shown to significantly reduce atherosclerosis. This vascular disease can lead to ischemic heart disease.

The aim of our working group is to identify basic cellular mechanisms in cardiovascular disease that can be transferred to and investigated in clinical trials.

We have recently shown that pharmacological inhibition of DPP4 (dipeptidyl-peptidase 4) can improve recruitment of regenerative cells from the blood into diseased cardiovascular tissue in a preclinical model. In a next step we were then able to translate these promising results into a phase III clinical trial.

Lab-2-Go puts Device through its Paces.

The university has launched a study of the practical application of a measuring device developed by four European companies that enhances the chances of recovery for cardiovascular patients.

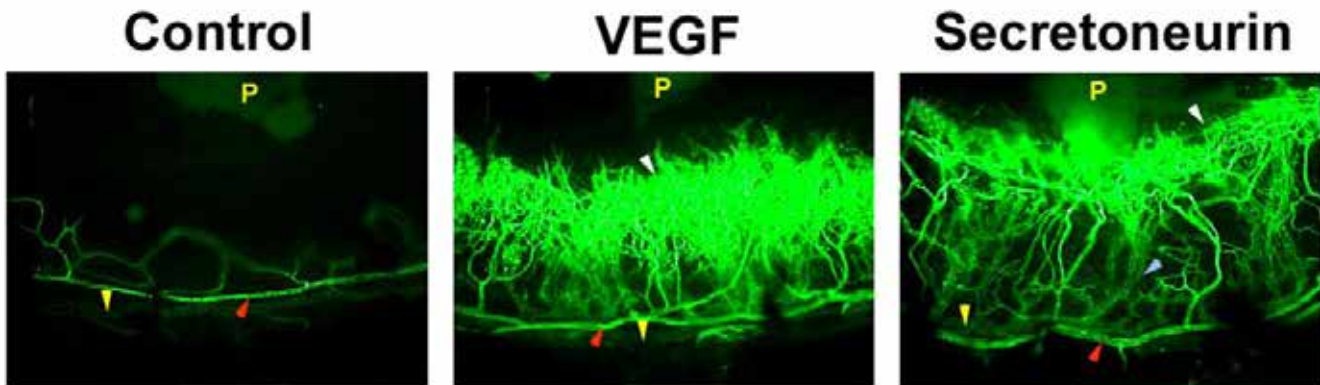

© R. Kirchmair

Fig. 2: Pellets (P) containing Control buffer, VEGF (vascular endothelial growth factor) or Secretoneurin were implanted into mouse corneas. Vessels are stained by fluorescence labelled lectin. Secretoneurin and VEGF induce growth of blood vessels out of limbus artery (red arrow) towards the pellet.

Leader: Prof. Johannes Mair

In suspected cases of acute myocardial infarction (AMI), rapid and reliable diagnosis improves the chances of survival, as well as minimising complications later on. Cardiac troponin I is a reliable indicator of heart muscle damage. This protein is normally identified in hospital laboratories, a process that takes at least an hour. However, four companies - Philips, Conworx Technology, Micro Systems Limited and Scienion AG - have come up with a handy biophotonic point-of-care measuring device called Minicare. The instrument should enable identification of cardiac troponin I in minutes, allowing doctors to diagnose myocardial damage.

Clinical Evaluation

As part of the EU's Lab-2-Go project, Professor Johannes Mair and his team (University Hospital for Internal Medicine III, Cardiology and Angiology) started a clinical study in mid-January 2015 to investigate the Minicare's application in practice and to improve technical applications in the system. A further six European cardiology centres, based in France, Germany, the Netherlands and the UK, are participating in this multi-centre study. The results are in-

tended to form the basis for fine-tuning the device, followed by approval of the Minicare diagnosis system in Europe and ultimately worldwide.

Therapeutic Angiogenesis by Secretoneurin and Catestatin

Leader: Prof. Rudolf Kirchmair.

Team members:

Markus Theurl M.D., Daniela Lener, Ursula Stanzl, Clemens Gutmann

We could recently demonstrate that the neuropeptides Secretoneurin and Catestatin induce angiogenesis in models of limb and cardiac ischemia. These findings were accompanied by positive effects on vascular cells as shown by stimulation of receptors for potent angiogenic cytokines like VEGF (vascular endothelial growth factor), FGF (fibroblast growth factor) and IGF (insulin-like growth factor). Secretoneurin gene therapy exerted these effects not only in healthy animals but also in Apo E knock out mice which exhibit a high vascular risk.

Future studies should evaluate exact mechanisms of Secretoneurin mediated

stimulation of growth factor receptors.

Selected Publications

Gliptins and their target dipeptidyl peptidase 4: implications for the treatment of vascular disease

Remm, Friederike, Franz, Wolfgang-Michael, Brenner, Christoph, EUROPEAN HEART JOURNAL-CARDIOVASCULAR PHARMACOTHERAPY: 2016; 2: S. 185-193

Combined therapy with sitagliptin plus granulocyte-colony stimulating factor in patients with acute myocardial infarction-Long-term results of the SITAGRAMI trial

Gross, Lisa, Theiss, Hans Diogenes, Grabmaier, Ulrich, Adrion, Christine, Mansmann, Ulrich, Sohn, Hae-Young, Hoffmann, Ellen, Steinbeck, Gerhard, Franz, Wolfgang-Michael, Brenner, Christoph, INTERNATIONAL JOURNAL OF CARDIOLOGY: 2016; 215: S. 441-445

Sitagliptin plus granulocyte colony-stimulating factor in patients suffering from acute myocardial infarction: A double-blind, randomized placebo-controlled trial of efficacy and safety (SITAGRAMI trial)

Brenner, Christoph, Adrion, Christine, Grabmaier, Ulrich, Theissen, Daniel, von Ziegler, Franz, Leber, Alexander, Becker, Alexander, Sohn, Hae-Young, Hoffmann, Ellen, Mansmann, Ulrich, Steinbeck, Gerhard, Franz, Wolfgang-Michael, Theiss, Hans Diogenes, INTERNATIONAL JOURNAL OF CARDIOLOGY: 2016; 205: S. 23-30

Pharmacological DPP4 inhibition for the prevention of vascular diseases

Brenner, C., Franz, W. M., INTERNATIONAL JOURNAL OF CARDIOLOGY: 2016; 202: S. 49-49

DPP-4 inhibition ameliorates atherosclerosis by priming monocytes into M2 macrophages

Brenner, C., Franz, W. M., Kuehlenthal, S., Kuschnerus, K., Remma, F., Gross, L., Theiss, H. D., Landmesser, U., Kraenkel, N., INTERNATIONAL JOURNAL OF CARDIOLOGY: 2015; 199: S. 163-169

Secretoneurin gene therapy improves hind limb and cardiac ischaemia in Apo E-/- mice without influencing systemic atherosclerosis

Theurl M, Schgoer W, Albrecht-Schgoer K, Lener D, Wolf D, Wolf M, Demetz E, Tymoszyk P, Tancevski I, Fischer-Colbrie R, Franz WM, Marschang P, Kirchmair R. Cardiovascular Research: 2015;105: S. 96-106

Oscillometric analysis compared with cardiac magnetic resonance for the assessment of aortic pulse wave velocity in patients with myocardial infarction

Feistritzer, Hans-Josef, Klug, Gert, Reinstadler, Sebastian J., Reindl, Martin, Mayr, Agnes, Schocke, Michael, Metzler, Bernhard, JOURNAL OF HYPERTENSION: 2016; 34: S. 1746-1751

Heart rate and left ventricular adverse remodelling after ST-elevation myocardial infarction

Reindl, Martin, Reinstadler, Sebastian Johannes, Feistritzer, Hans-Josef, Tiller, Christina, Mayr, Agnes, Klug, Gert, Metzler, Bernhard, INTERNATIONAL JOURNAL OF CARDIOLOGY: 2016; 219: S. 339-344

Prognostic value of left ventricular global function index in patients after ST-segment elevation myocardial infarction

Reinstadler, Sebastian J., Klug, Gert, Feistritzer, Hans-Josef, Kofler, Markus, Pernter, Bastian, Goebel, Georg, Henninger, Benjamin, Mueller, Silvana, Franz, Wolfgang-Michael, Metzler, Bernhard, EUROPEAN HEART JOURNAL-CARDIOVASCULAR IMAGING: 2016; 17: S. 169-176

Cardiomyocyte-derived CXCL12 is not involved in cardiogenesis but plays a crucial role in myocardial infarction

Muehlstedt, Silke, Ghadge, Santhosh K., Duchene, Johan, Qadri, Fatimunnisa, Jaerve, Anne, Vilianovich, Larisa, Popova, Elena, Pohlmann, Andreas, Niendorf, Thoralf, Boye, Philipp, Ozcelik, Cemil, Bader, Michael, JOURNAL OF MOLECULAR MEDICINE: 2016; 94: S. 1005-1014

Selected Funding

- Ass.-Prof. M.M. Zaruba: FWF P28817-B28: "Smooth muscle specific role of SDF-1 in cell recruitment and cardiac repair after MI". 327.512 Euro.
- Dr. Markus Theurl: FWF P26251 : "Catestatin for treatment of myocardial ischemia". 262.731 Euro.

Collaborations

- Charité Centrum Herz-, Kreislauf- und Gefäßmedizin, Medizinische Klinik für Kardiologie, Berlin, Deutschland: Dr. Nicolle Kränkel, Univ.-Prof. Dr. Ulf Landmesser
- Medizinische Klinik und Poliklinik I, Klinikum der Universität München - Großhadern, Deutschland: Prof. Dr. Hans Theiss, Dr. med. Sebastian Clauß
- Prof. H. Arheden at the University Lund, Sweden
- Prof. Dr. H. Thiele at the University Lübeck, Germany

Internal Medicine IV



Director:
Univ.-Prof. Dr. Gert Mayer

Contact:
Anichstraße 35
6020 Innsbruck

Gert.Mayer@i-med.ac.at
Phone: +43 512 504 25855
Fax: +43 512 504 25857
<https://nephrologie.tirol-kliniken.at>

Research Branch (ÖSTAT Classification)

302050

Keywords

Chronic kidney disease, pathophysiology, systems biology, stratified/personalized medicine, epidemiology, autoimmune disease, hemodialysis, cardiovascular mortality, renal transplantation

Research Focus

In order to better characterize patho-physiologically complex phenotypes such as chronic kidney disease, we apply modern epidemiology and “Omics”-techniques in conjunction with state of the art systems biology approaches to derive prognostic and predictive biomarkers to implement innovative stratified/personalized treatment. This translational research focus is supported by experimental and clinical studies in selected populations and by strong national and international collaborations.

General Facts

The Department is the tertiary referral centre for patients with acute and chronic renal diseases (native kidney, renal replacement therapy, kidney transplantation) and hypertension for the Western part of Austria and Southern Tyrol. Specialised outpatients as

well as inpatients facilities and a state of the art unit for extra-corporeal therapy (hemo- as well as peritoneal dialysis, plasmapheresis, liver support therapy, immune-adsorption) allow us to serve a large clinical population and this background drives our translational research efforts. The laboratories of the Department maintain a clinical routine as well as a molecular biology (including microarray facility) and cell culture unit. Our clinical trial core unit manages investigator driven projects as well as the participation in large multicentre clinical trials and a large bio-banking effort.

The most recent project is to relocate the „Austrian Dialysis and Transplantation Registry“ to Innsbruck in collaboration with the Department of Statistics, Informatics and Health Economy. The common denominator of the Department’s research activity is the area of personalized/stratified medicine in the various aspects of Nephrology and we collaborate with multiple academic and industry partners in national and/or EU funded projects. During our recent activities we focused primarily on the application of systems-biology techniques within the FP 7 funded project SysKid, to which our Department was one of the main contributors. Last year a successor project (Beat-DKD) was funded by the Innovative Medicine Initiative. Beat-DKD again is a large consortium project with 28 academic and industry partners and next to WP lead functions our

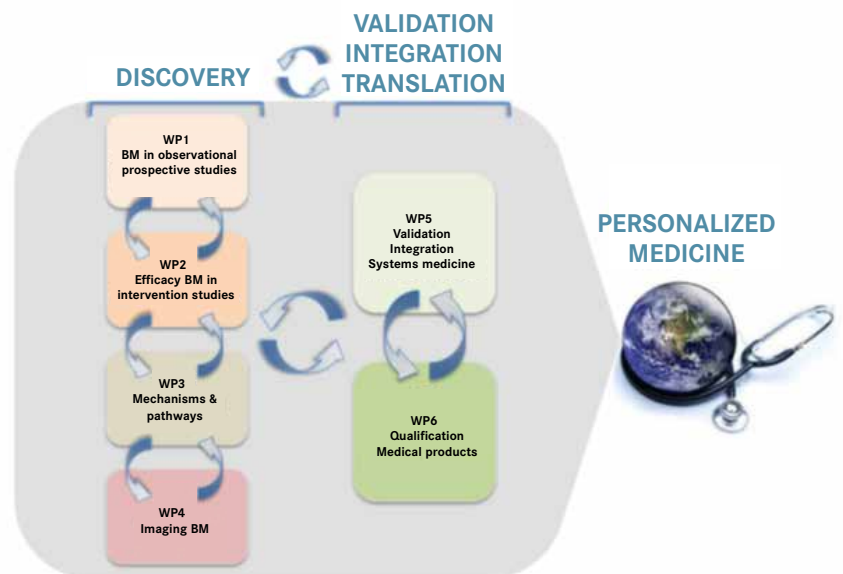

Fig. 1: The work package structure of Beat-DKD.

Department is involved in various research activities (figure 1).

Research

Basic Research Activities

Cellular and Molecular Nephrology

Lead: Herbert Schramek MD,
Markus Pirklbauer MD

Diabetes mellitus (DM) is a major and growing health problem worldwide. Normalizing hyperglycemia is not only crucial for slowing progression of the disease process but also for preventing secondary consequences such as diabetic nephropathy. Sodium glucose cotransporters SGLT2 and SGLT1 in the apical membrane of the proximal tubule have been established as the primary mechanisms of glucose reabsorption in the kidney. Inhibitors of SGLT2 have recently been approved for human use in type 2 DM. Although studies in mice have shown that pharmacological SGLT2 inhibition itself increases renal SGLT2 protein expression and although expression of SGLT2 mRNA and protein is increased in renal biopsies from human subjects with diabetic nephropathy, there is very limited data in the literature about the regulation of sodium gradient dependent glucose transporter expression. The lab is currently studying the effects of pharmacological inhibitors of sodium glucose cotransporters on gene expression in human proximal tubular cells. Utilizing two SGLT2 inhibitors, namely Empagliflozin and Canagliflozin, we investigate their effects on SGLT2 and GLUT2 expression in the presence and in the absence of pro-inflammatory and pro-fibrotic ligands such as IL-1 β and TGF- β 1. Additional study endpoints are the expression of TSP-1, CTGF, CCL2, CCL5, and IL-6. In a second ongoing experimental approach, cDNA microarray analysis is performed in the two independent proximal tubular cell lines RPTEC/TERT1 and HK-2 exposed either to Empagliflozin or Canagliflozin when compared with untreated control cells. One of several interesting preliminary results of these studies is shown in figure 2.

Translational Research Activities

Transcriptional Profiling and Systems Biology Application in Chronic Renal Disease

Lead: Johannes Leierer PhD, Gert Mayer MD
Several years ago we established (in collaboration with the University of Stanford/California) microarray technology to study whole organ and, via application of laser

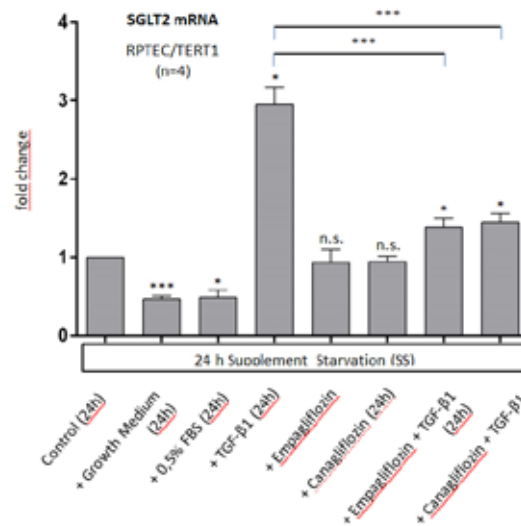

Fig. 2: The effect of SGLT-2 inhibitors and cytokines on SGLT-2 mRNA expression levels in the proximal tubular cell line RPTEC/TERT1

capture micro-dissection, renal compartment specific differential mRNA and miRNA expression in human and animal tissue, Doz. Dr. Michael Rudnicki focuses on respective combined data analysis. In collaboration with the Mario Negri Institute (Bergamo/Italy) we were able to identify and characterize a novel miRNA (miR-184) as a downstream effector of albuminuria, which drives renal fibrosis in a rat model of diabetic nephropathy. Further miRNAs are being studied as serum biomarkers to distinguish diabetic from non-diabetic renal diseases. Recently, in-house generated transcriptomics data were complemented by proteomic, metabolomic and genomic profiles in the large, multinational EU FP-7 funded project SysKid (Systems Biology towards Novel Chronic Kidney Disease). In collaboration with EMERGENTEC biodevelopment and the Medical Universities of Vienna and Groningen we developed a system biology derived molecular model of renal disease in type II diabetes and identified molecular processes associated with progressive renal function loss. Biomarkers reflecting these pathways were discovered and validated in large patient cohorts. Currently we are working to match the disease specific molecular profiles with drug mode of action molecular profiles to gain access to targeted therapy. This approach will be put forward in the IMI project BEAT-DKD, which started late 2016 and coordinates the efforts of many academic centres from around the world and

pharmaceutical industry, and in the Austrian TOPVAS study, which recruits patients after renal transplantation and dissects the effects of ageing on transcriptional profiles in the kidney and calcineurin inhibitor toxicity. In order to validate our “*in silico*” derived hypotheses on predictive biomarkers we are also leading several large scale, national and multinational prospective cohort studies with (e.g. PROVALID, a study in 4,000 patients with type 2 diabetes in 5 European countries; TOPVAS including 240 patients after renal transplantation in Austria) or without bio-banking (Austria Dialysis and Transplant Registry). The data collected there form the basis for outcomes and health economics research on a European level.

Assoc. Prof. Dr. Hannes Neuwirt, another team member, is working on biomarkers that predict long term graft function and the role of the complement system in kidney transplant models. A further clinical research focus is on ABO incompatible renal transplantation. Additionally Dr. Neuwirt is exploring alternative dialysis modalities, such as electro-osmosis in collaboration with Prof. Thomas Bechtold (Research Institute of Textile Chemistry and Textile Physics University).

Dr. Julia Kerschbaum, MSc, a further member of our team, is working on prediction models for adverse events in patients with

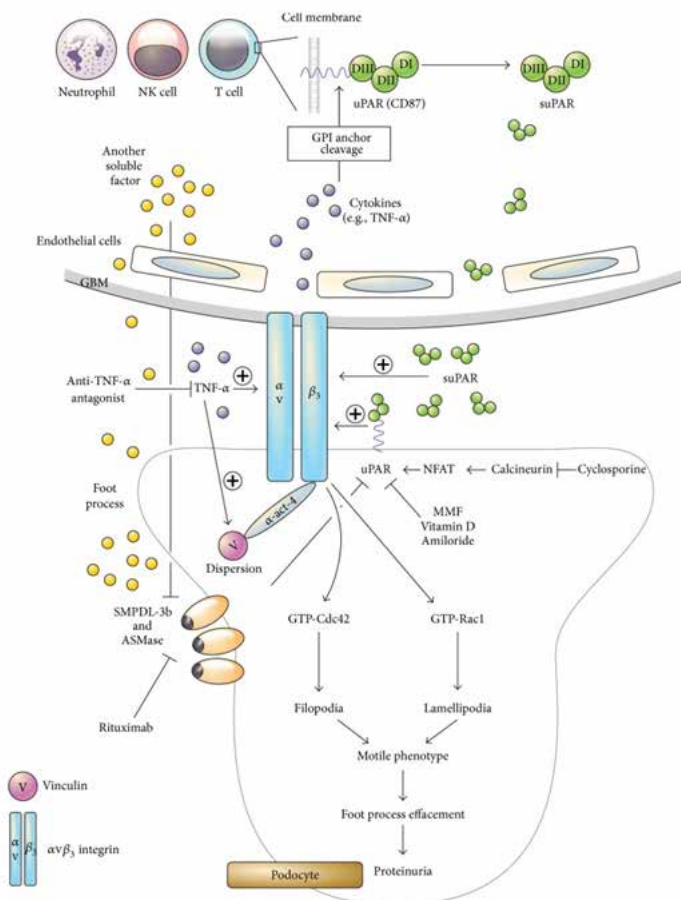

Fig. 3: A current concept of our understanding of FSGS: A circulatory factor, yet to be identified, leads to podocyte damage and this again may initiate the onset of nephrotic syndrome. Several factors, including soluble urokinase plasminogen activator receptor (suPAR) have been discussed, leading to β_3 -integrin activation and downstream to podocyte changes (foot process effacement and proteinuria)

tional studies on the safety of the ADH antagonist Tolvaptan for treatment of autosomal-dominant polycystic kidney diseases.

Living kidney donation is the optimal treatment for patients with end-stage renal disease, but data on the risks for the donors are controversially discussed. In a close collaboration with the Department of Visceral, Transplant and Thoracic Surgery we evaluated the long-term clinical course of live kidney donors who donated their kidney in Innsbruck between 1985 and 2015. The risks of chronic kidney and cardiovascular disease have been quantified, and risk factors have been identified, which are now being used for risk stratification of future kidney donors. In addition we currently evaluate the impact of donor characteristics on the graft function of the recipient.

Regarding the excessive cardiovascular mortality in patients with end stage renal disease, Markus Pirklbauer investigates the possible detrimental effect of positive calcium mass balance during hemodialysis. Supported by an educational research grant provided by the Austrian National Bank we recently published first experimental evidence for the existence of a rapidly exchangeable calcium pool counteracting acute deviations of extracellular calcium concentration in hemodialysis patients, and for the involvement of bone in acute extracellular calcium regulation *in vivo*. Based on the promising results of our acute calcium kinetics studies we are currently establishing a research-collaboration with the Renal Research Institute New York (Head: Prof. Peter Kotanko).

chronic kidney disease. In particular, she is interested in the prediction of cardiovascular events and kidney failure in patients with type II diabetes. Furthermore, she is working on general epidemiological issues in order to identify factors which might improve prognosis in our patients and she is a main contributor to the “Austrian Dialysis and Transplantation” registry transfer.

Clinical Research Activities

Targeted Therapy in Renal Disease

Lead: Michael Rudnicki MD (peritoneal dialysis, anti CD20, rare diseases such as ADPKD or Mb. Fabry, live kidney donation), Markus Pirklbauer MD (cardiovascular mortality on hemodialysis); Andreas Kronbichler MD (autoimmune diseases)

Peritonitis is the most serious complication in patients on peritoneal dialysis (PD). In an

analysis of PD patients treated locally and in a multicentre national study, Julia Kerschbaum and Michael Rudnicki identified factors associated with risk of peritonitis. Interestingly oral active vitamin D therapy was associated with a decreased incidence and improved survival. In collaboration with the Department of Nephrology, Ospedali Riuniti di Bergamo/Italy, we examined the effect of an anti-CD20 antibody in frequently relapsing nephrotic diseases in children and in adults.

Based on data obtained in a prospective study and a review we were able to show that this approach is a valuable therapeutic option. In collaboration with the Department for Pediatrics we treat and recruited patients with rare diseases, in particular Fabry’s disease, into a European multicentre study on enzyme replacement therapy. We also participate in national and interna-

© J Immunol Res. 2016

the onset/relapse of the disease. Thus, the future aims are to combine clinical findings with an experimental setting to increase the understanding of these diseases. These efforts are driven forwards via collaboration with Dr. David Jayne (Cambridge University Hospitals, UK). From a clinical perspective, we are mainly interested in complications of immunosuppressive treatment, i.e. infectious complications, malignancy and venous thromboembolic events.

Clearly, the future aim will be a combination of these events with a mechanistic approach potentially revealing patients at risk to develop such complications. This effort is driven via collaborations within the European Vasculitis Society. In addition, the research group will participate in several clinical trials and is currently co-investigator in a European trial aiming to investigate the role of extracorporeal treatment (IAS) in refractory SLE.

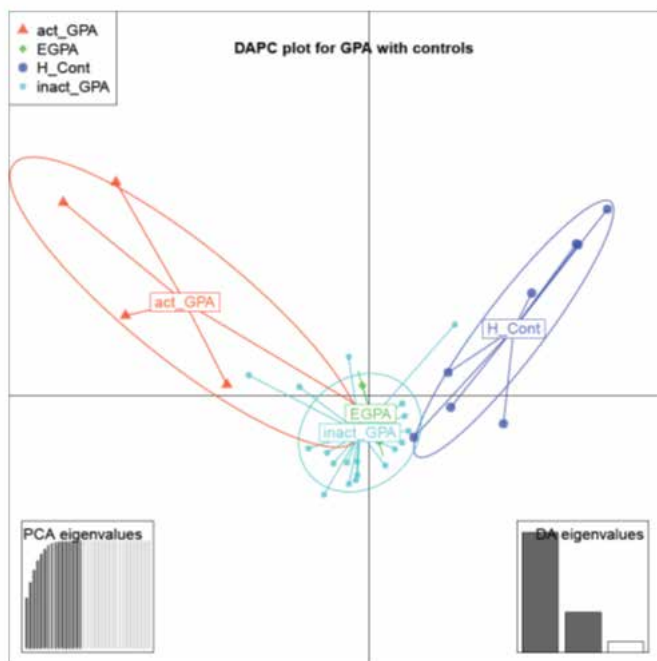

Fig. 4: The "bacterial signature" of patients with vasculitis may help to discriminate active patients from inactive, healthy and diseased controls.

Selected Publications

Effect of rituximab on malignancy risk in patients with ANCA-associated vasculitis
van Daalen EE, Rizzo R, Kronbichler A, Wolterbeek R, Bruijn JA, Jayne DR, Bajema IM, Rahmattulla C
ANN RHEUMDIS: 2016; doi: 10.1136/annrheumdis-2016-209925

International Network of Chronic Kidney Disease cohort studies (iNET-CKD): a global network of chronic kidney disease cohorts
Dienemann T, Fujii N, Orlandi P, Nessel L, Furth SL, Hoy WE, Matsuo S, Mayer G, Methven S, Schaefer F, Schaeffner ES, Solá L, Stengel B, Wanner C, Zhang L, Levin A, Eckardt KU, Feldman HI.
BMC NEPHROL 2016 doi: 10.1186/s12882-016-0335-2

Acute calcium kinetics in haemodialysis patients

Pirklbauer M, Schupart R, Mayer G
EUR J CLIN INVEST 2016;46:976-984

Renal microRNA- and rRNA-profiles in progressive chronic kidney disease.

Rudnicki M, Perco P, D'haene B, Leierer J, Heinzel A, Mühlberger I, Schweibert N, Sunzenauer J, Regele H, Kronbichler A, Mestdagh P, Vandesompele J, Mayer B, Mayer G.
EUR J CLIN INVEST 2016;46:213-26

Selected Funding

- Hämoelektroosmose; Austria Wirtschaftsservice Ges.m.b.H. ; Hannes Neuwirt
- Arthritis Research UK Microbiome Pathfinder Award; Andreas Kronbichler

Collaborations

- Bernd Mayer, EMERGENTEC biodevelopment GmbH; Vienna, Austria
- Rainer Oberbauer, Division of Nephrology and Dialysis; Medical University Vienna
- Harald Mischak, Mosaiques Diagnostics GmbH; Hannover, Germany
- Peter Rossing, STENO Diabetes Center; Gentofte, Denmark
- Johannes Mann, Universität Erlangen; Erlangen, Germany
- Dick de Zeeuw, Hiddo Lambers Heerspink, Academisch Ziekenhuis; Groningen, The Netherlands
- Andrzej Wiecek, Slaski Uniwersytet Medyczny Katowicach; Kattowice, Poland
- Laszlo Rosivall, Semmelweis University; Budapest, Hungary
- Patrick Mark, University of Glasgow; Glasgow, UK
- Timothy Meyer, Stanford University School of Medicine; California, USA
- David Jayne, Vasculitis and Lupus Clinic, Cambridge University Hospitals; United Kingdom
- Annette Bruchfeld, Division of Renal Medicine, Karolinska Institutet; Stockholm, Sweden
- Daiki Nakagomi, Department of Allergy and Clinical Immunology, Chiba University; Chiba, Japan
- Thomas Neumann, Department of Internal Medicine III, Jena University Hospital; Jena, Germany
- Jae Il Shin, Department of Pediatric Nephrology, Yonsei University College of Medicine, Severance Children's Hospital; Seoul, Korea
- Piero Ruggenenti, Department of Nephrology, Ospedali Riuniti di Bergamo/Italy
- Peter Kotanko, Renal Research Institute, Mt Sinai Medical Center, New York, USA
- Mathias Kretzler, Ann Arbor University Michigan, USA

Internal Medicine V



Director:
Univ.-Prof. Dr. Günther Gastl

Contact:
Anichstraße 35
6020 Innsbruck

Guenther.Gastl@i-med.ac.at
Phone: +43 512 504 24003
Fax: +43 512 504 25615
www.haematologie-onkologie.at

Research Branch (ÖSTAT Classification)

302024, 302055, 302058,
302013, 302009

Keywords

Personalized cancer medicine, precision oncology, geriatric assessment, molecular profiling, 3D tumor tissue culture, biomarker, immuno-oncology

Research Focus

The clinical research of The Department of Internal Medicine 5 (UKIM5) is focused on interventional clinical trials (phase I – III), clinical drug development and health care research, including clinical outcome research in “real life”, clinical decision making and cost-effectiveness analysis of therapeutic interventions in hematology and oncology. UKIM5 is dedicated to promote and further develop the principles of personalized cancer medicine for curative and palliative cancer medicine based on patient assessment, tumor profiling and continuous disease monitoring. As core infrastructure of the Comprehensive Cancer Center Innsbruck (CCCI), UKIM5 cooperates with its clinical partners at the University Hospital, the OncoNetwork of Western Austria/South Tyrol and with clinical research groups and networks at the national and international level.

Translational research is focused on biomarker research & development using in vitro test systems and tissues and body fluids collected ex vivo, comprehensive molecular cancer profiling, drug testing in vitro and in vivo and development of combinatorial treatment approaches including antiangiogenic and immunotherapeutic interventions. Within the CCCI UKIM5 collaborates in translational and basic cancer research with its clinical partners, preclinical institutes and research facilities (eg., CCB, Austrian Drug Screening Institute), ONCOTYROL, the Tyrolean Cancer Research Institute, UMIT, and research institutions, networks and platforms in Austria, Europe and in the US.

General Facts

UKIM5 comprises a 50 bed-hospital including a stem cell transplantation unit, an outpatient clinic, an oncology trial center (OTC), laboratory services, translational research facilities and a FACS sorting core facility. UKIM5 provides state-of-the-art care primarily for patients with non-malignant and

malignant hematological diseases and solid neoplasms. Interdisciplinary competence centers have been established for hematological diagnostics (IHK) and hematopoietic stem cell production (ICCT). In 2016, 30-40 clinical studies were active for patient recruitment. Approximately 10% of the cancer patients are currently entered into academic or industry-sponsored clinical studies. In addition, UKIM5 plays a major role in health care research as coordinating center for several regional and national registries (CML, myeloma, MDS, lymphoma, lung cancer, soft tissue sarcoma). Further, since 2012 UKIM5 offers a postgraduate Clinical PhD program for Clinical Cancer Research.

Research

Tumor Angiogenesis

Doz. Dr. Eberhard Gunsilius

The tumor angiogenesis group investigates predictive biomarkers for antiangiogenic therapies and screens natural and synthetic compounds for their anti-angiogenic activity in-vivo using the chorion allantois membrane (CAM) assay. Novel marine-derived compounds were tested for anti-myeloma and antiangiogenic activities in vitro and in vivo. Multiple myeloma (MM) cell lines NCI-929, OPM-2 and U266 and primary human MM cells were used for in vitro drug testing. In addition, a culture system of MM cells was established in a bone-resembling matrix, where eGFP-transfected MM cell lines allowed the determination of tumor growth and apoptosis by a GFP-ELISA and visualization of the tumor size by confocal microscopy in vitro and in vivo (MM xenografts in the CAM assay). 4 marine compounds (Plitidepsin, Zalypsis, PM00113, and Thiocoraline A) showed considerable anti-myeloma activity *in vitro* and *in vivo*. Apart from directly affecting myeloma cells, marine-derived compounds (Plitidepsin-analogs PM01215 and PM02781) also exert antiangiogenic activity on HUVECs at nanomolar concentrations. Moreover, some compounds inhibited angiogenesis in vivo (CAM assay). Two analogs of Plitidepsin were shown to induce cell cycle arrest in G1 phase, expression of the cell cycle inhibitor p16INK4A and senescence-associated beta galactosidase activity. PM01215 and PM02781 induce oxidative stress and cause alterations in vascular maturation factors Vasohibin-1 and Dickkopf-3.

The cytokine FLT3-ligand (FLT3-L) is involved in the growth and differentiation of hematopoietic cells and is involved in the angiogenic processes of MM. FLT3-L was

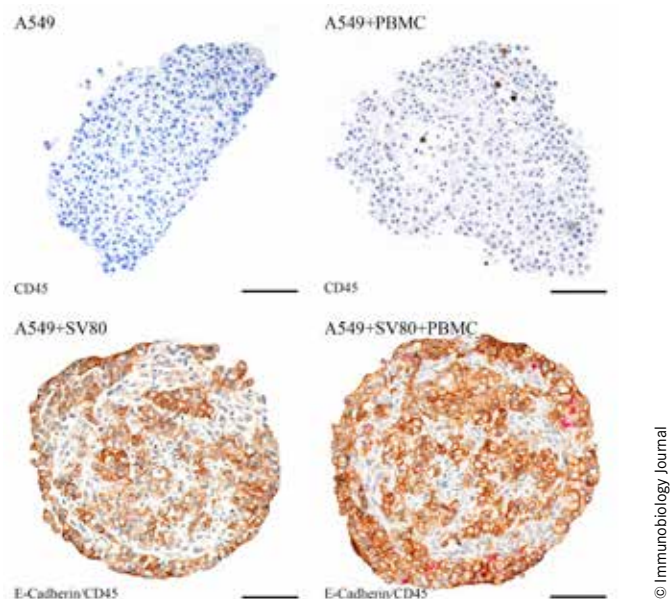

Fig. 1: Cell line A549 (A) (B) and A549 + SV80 fibroblasts (C) (D) cultured for 10 days followed by co-incubation with PBMC (for 24 h) with or without IL-2. Anti-E-cadherin (brown) and anti-CD45 (red) double staining; Bar 100 μ m

evaluated in bone marrow of MM patients for its prognostic significance. Bone marrow plasma levels of FLT3-L were determined in patients with monoclonal gammopathy of undetermined significance (MGUS), patients with newly diagnosed MM (NDMM) and patients with relapsed/refractory MM (RRMM) by a sandwich ELISA. High levels of FLT3-L (threshold FLT3-L >92 pg/ml) in bone marrow of MM patients identify patients with progressive disease and are associated with relapse or refractoriness

in MM patients. Thus FLT3-L could become useful as a biomarker for early identification of RRMM patients. Further, the research group focused on differences in responses to proteasome inhibition (PI) and unfolded protein responses (UPR) between sensitive and refractory MM and intrinsically resistant solid tumor cell lines. Responsiveness to Bortezomib (BTZ) is based on a complete inhibition of the proteasome in MM cells and intact induction of p53/Noxa-mediated apoptosis. Currently, research is fo-

cused on molecular profiles of MM and genetic changes in MM-associated vascular endothelium.

Translational Oncology

Prof. Dr. Heinz Zwierrina

This group developed a 3D cell culture ("hanging-drop system") model reflecting the tumor microenvironment ("microtissues"). The compound culture model consists of 3 different cell types (tri-culture), cancer cells, fibroblasts and endothelial cells. This cell culture model using cell lines can be used for investigating infiltrating immune cells in cancer tissue (Fig 1). Recently, in cooperation with the Depts of Surgery and Pathology, primary tumor tissue from cancer patients was cultivated to generate 3D microtissues from lung and GI carcinomas (Fig. 2). Currently, the effect of autologous immune cells on matched cancer microtissues is being investigated. Further, this group is establishing a biobank for "liquid biopsies" from cancer patients undergoing immunotherapeutic interventions.

Biomarkers for Tumor Immunity & Immune Monitoring

PD Dr. Sieghart Sopper

A major topic of the group is the phenotypic and functional characterization of immune cells involved in tumor-host interactions and during treatment of different cancer entities. This includes assessment of leukocyte subpopulations in the blood of hematologic malignancies (CML, MDS) as well as investigations of immune competent cells isolated from solid tumor tissue derived

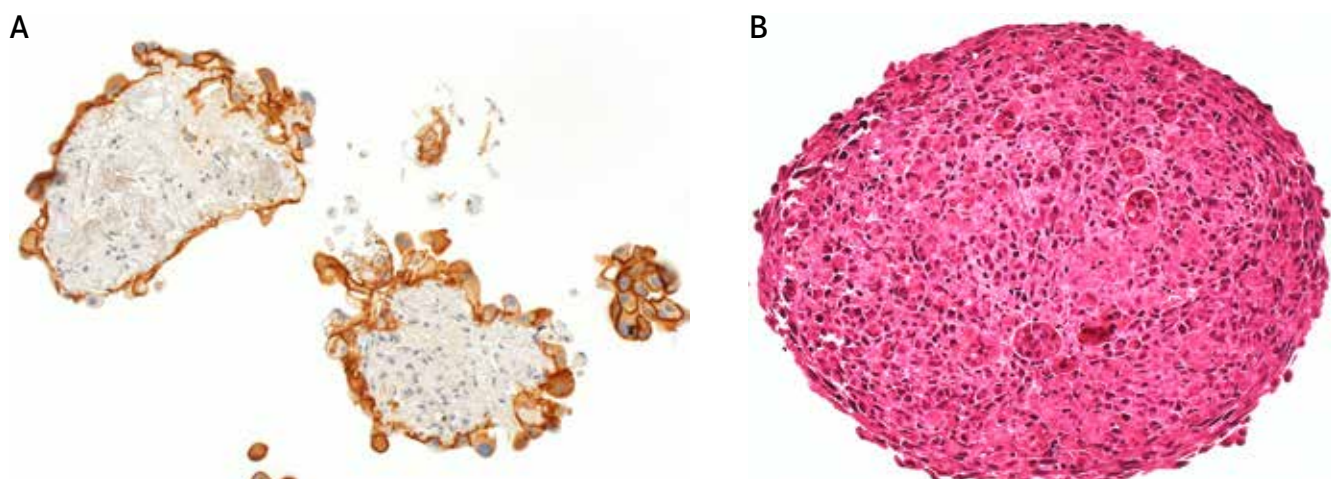

Fig. 2: Microtissue established from NSCLC cancer in a hanging drop (panel A, 40x) and a HE stained section (panel B) of FFPE microtissue.

from lung and ovarian cancer. By combining multidimensional flow cytometry with multiplex determination of soluble analyte, levels of CD62L in peripheral blood were found to be predictive for molecular responses of CML patients to TKI treatment. With a new high-end flow cytometer funded by the FFG this research area will be expanded in the near future.

Cancer stem cells provide potential targets for immunotherapeutic interventions. In a systematic screen of dozens of cancer cell lines, we found that expression of ABC transporters defines cells with stem cell properties. Using differential gene expression analysis, we identified the guanine exchange factor VAV3 as a potential stem cell specific target. Expression of a truncated variant of VAV3 was found to be associated with refractiveness to platinum based therapy in a cohort of ovarian cancer patients. A patent was filed on the use of VAV3 splice variants as a novel biomarker for cancer. The next steps include the validation of this marker in other cancer entities and investigations of the function of the truncated variant in malignant cells as well as its immunogenic potency.

Biology of Ageing and Personalised Treatment of Elderly Cancer Patients

Prof. Dr. Stauder, MSc

This group is focused on integrating a patient's individual health status (comorbidities, performance and nutritional status) and health-related quality of life (HRQoL including mood, mobility, depressions, functions of daily living) in treatment decisions in order to improve clinical outcome and ameliorate treatment-related toxicities. Currently two research projects promote these goals: (1) the ERA-NET "Triage-MDS" Translational Implementation of genetic evidence in the management of MDS project within the TRANSCAN primary and secondary prevention of cancer call, and the H2020 project MDS-RIGHT (providing the right care to the right patient within the MyeloDysplasticSyndrom at the right time). Both projects are embedded in the EUMDS Registry of the European Leukemia Network (ELN). The TRIAGE-MDS project focuses on next generation sequencing of MDS patient samples in order to improve targeted therapy depending on mutation profiles of individual patients. The interplay of molecular aberrations, assessment status and anemia are analyzed and compared with reference populations to elucidate mechanisms of ageing both in frail and in elderly cancer patients. These analyses form the basis for individualized treatment algorithms and es-

tablish the relevance of assessment scores including HRQoL and functional capacities as patient-reported outcomes (PROs). The MDS-Right project has a strong focus on HRQoL in MDS cancer patients with the aim of improving HRQoL by taking into account impairments assessed with recently developed questionnaires (QUALMS). The ultimate goal is to develop guidelines to tailor healthcare interventions according to a patient's individual needs. In 2016, Prof. Stauder received the prestigious Paul Calabresi Award from the International Society of Geriatric Oncology (SIOG) for outstanding achievements in geriatric oncology (Fig. 3).



Fig. 3: Prof. Reinhard Stauder, Recipient of the Paul Calabresi Award from the International Society of Geriatric Oncology (SIOG)

Experimental & Clinical Cancer Genomics

PD Dr. Gerold Untergasser,

Prof. Dr. Michael Steurer

This group is focused on molecular profiling of solid tumors and hematological malignancies in order to genomically characterize malignancies at diagnosis, recurrence and at the refractory stage. Molecular profiling is mainly based on targeted NGS technology and is supplemented by expression profiling, immunohistochemistry, flow cytometry and ELISA. The primary goal is the detection of prognostic and/or predictive genomic biomarkers and druggable driver mutations or down-stream signaling pathways for selecting appropriate targeted agents or combinatorial therapeutic strategies. In solid tumors, the role of EpCAM as a prognostic and predictive biomarkers has been studied for more than 10 years. Recently, monoclonal antibodies recognizing the extracellular portion and the intracellular signaling part of the EpCAM molecule have been developed, allowing investigation of the signaling state of this transmembrane cell adhesion molecule. In 2015, a collaboration with Caris Life Sciences (Phoenix, USA) was started for profiling recurrent or refractory solid tumors and designing therapies according to molecular profiles (ONCO-T-PROFILE program). In addition, multiple myeloma and B-CLL have been selected as malignant disease models in order to investigate the clonal evolution of these cancers and to identify potential therapeutic targets during disease progression. Recently, molecular profiling has been complemented by immunoprofiling of solid and liquid neoplasms (in collaboration with the Tumor Immunology Group) and a clinical program (COMBASKET) was set up for combinatorial therapeutic interventions with immune checkpoint blockade as a backbone.

Selected Publications

Translational Oncology Group

Infiltration of lymphocyte subpopulations into cancer microtissues as a tool for the exploration of immunomodulatory agents and biomarkers

Koeck S, Zwierzina M, Huber JM, Bitsche M, Lorenz E, Gameraith G, Dudas J, Kelm JM., Zwierzina H, Amann A
IMMUNOBIOLOGY: 2016; 221: S. 604-617

Evaluation of assays for drug efficacy in a three-dimensional model of the lung

Huber J M, Amann A, Koeck S, Lorenz E, Kelm JM., Obexer P, Zwierzina H, Gameraith G
JOURNAL OF CANCER RESEARCH AND CLINICAL ONCOLOGY: 2016; 142: S. 1955-1966

The impact of metformin and salinomycin on transforming growth factor-induced epithelial-to-mesenchymal transition in non-small cell lung cancer cell lines

Koeck S, Amann A, Huber JM., Gameraith G, Hilbe W, Zwierzina H
ONCOLOGY LETTERS: 2016; 11: S. 2946-2952

Treatment of patients with refractory metastatic cancer according to molecular profiling on tumor tissue in the clinical routine: an interim-analysis of the ONCO-T-PROFILE project.

Seeber A, Gastl G, Ensinger C, Spizzo G, Willenbacher W, Kocher F, Leitner C, Willenbacher E, Amann A, Steiner N, Eisterer W, Voss A, Russell K, Zwierzina H.
GENES & CANCER. 2016;7: S.301-308

Biology of Aging & Personalized Treatment of Elderly Cancer Patients

Clinical judgement and geriatric assessment for predicting prognosis and chemotherapy completion in older patients with a hematologic malignancy

Hamaker M. E., Augschoell J., Stauder R.,
LEUKEMIA & LYMPHOMA: 2016; 57: S. 2560-2567

Time-dependent changes in mortality and transformation risk in MDS

Pfeilstoeker M, Tuechler H, Sanz G, Schanz J, Garcia-Manero G, Sole F, Bennett JM, Bowen D, Fenaux P, Dreyfus F, Kantarjian H, Kuendgen A, Malcovati L, Cazzola M, Cermak J, Fonatsch C, Le Beau MM, Slovak M L, Levis A, Luebbert M, Maciejewski J, Machherndl-Spandl S, Magalhaes SM, Miyazaki Y, Sekeres MA, Sperr WR, Stauder R, Tauro S, Valent P, Vallespi T, van de Loosdrecht AA, Germing U, Haase D, Greenberg PL
BLOOD: 2016; 128: S. 902-910

Cytopenia levels for aiding establishment of the diagnosis of myelodysplastic syndromes

Greenberg PL, Tuechler H, Schanz J, Sanz G, Garcia-Manero G, Solé F, Bennett JM, Bowen D, Fenaux P, Dreyfus F, Kantarjian H, Kuendgen A, Levis A, Malcovati L, Cazzola M, Cermak J, Fonatsch C, Le Beau MM, Slovak ML, Krieger O, Luebbert M, Maciejewski J, Magalhaes SM, Miyazaki Y, Pfeilstöcker M, Sekeres M, Sperr WR, Stauder R, Tauro S, Valent P, Vallespi T, van de Loosdrecht AA, Germing U, Haase D.
BLOOD: 2016; 128: S. 2096-2097

Marine compounds inhibit growth of multiple myeloma in vitro and in vivo.

Steiner N, Ribatti D, Willenbacher W, Jöhner K, Kern J, Marinaccio C, Aracil M, Garcia-Fernandez LF, Gastl G, Untergasser G, Gunsilius E.
ONCOTARGET: 2015; 6: S. 8200-8209

The Aplidin analogs PM01215 and PM02781 inhibit angiogenesis in vitro and in vivo.

Borjan B, Steiner N, Karbon S, Kern J, Francesch A, Hermann M, Willenbacher W, Gunsilius E, Untergasser G.
BMC CANCER: 2015; 15: S. 738

Tumor Immunology Biomarkers & Immune Monitoring

The nuclear orphan receptor NR2F6 is a central checkpoint for cancer immune surveillance.

Hermann-Kleiter N, Klepsch V, Wallner S, Siegmund K, Klepsch S, Tuzlak S, Villunger A, Kaminski S, Pfeilhofer-Obermair C, Gruber T, Wolf D, Baier G. CELL REPORTS: 2015; 12: S. 2072-2085

Heterogeneity of Cancer Stem Cells: Rationale for Targeting the Stem Cell Niche.

Boesch, M., S. Sopper, A.G. Zeimet, D. Reimer, G. Gastl, B. Ludewig, and D. Wolf,
BIOCHIMICA ET BIOPHYSICA ACTA-REVIEWS ON CANCER: 2016; 1866: S. 276-289

High prevalence of side population in human cancer cell lines.

Boesch, M., A.G. Zeimet, H. Fiegl, B. Wolf, J. Huber, H. Klocker, G. Gastl, S. Sopper, and D. Wolf, ONCOSCIENCE: 2016; 3: S. 85-87

On-demand erythrocyte disposal and iron recycling requires monocyte-derived transient macrophages in the liver.

Theurl I, Hilgendorf, M, Nairz, P, Timoszuk, D, Haschka, M, Asshoff, S, He, L, Gehradt, T, Holderried, M, Seifert, S, Sopper, A, Fenn, A, Anzai, S, Rattik, C, McAlpine, M, Theurl, P, Wieghofer, Y, Iwamoto, G, Weber, N, Harder, B, Chousterman, T, Arvedson, M, Mckee, F, Wang, O, Lutz, E, Rezoagli, J, Babbitt, L, Berra, M, Prinz, M, Nahrendorf, G, Weiss, R, Weissleder, H.Y.Lin, F.K. Swirski. NATURE MEDICINE: 2016; 22: S. 945-+

Experimental & Clinical Cancer Genomics

Detection of soluble EpCAM (s(EpCAM) in malignant ascites predicts poor overall survival in patients treated with catumaxomab.

Seeber A, Brajcu I, Untergasser G, Nassir M, Fong D, Botta L, Gastl G, Fiegl H, Zeimet A, Sehouli J, Spizzo G.
ONCOTARGET: 2015; 6: S. 25017-25023

Soluble EpCAM levels in ascites correlate with positive cytology and neutralize catumaxomab activity in vitro

Seeber A, Martowicz A, Spizzo G, Burattio T, Obrist P, Fong D, Gastl G, Untergasser G. BMC CANCER: 2015; 15: S. 372

Predominant expression of truncated EpCAM is associated with a more aggressive phenotype and predicts poor overall survival in colorectal cancer

Seeber A, Untergasser G, Spizzo G, Terracciano L, Lugli A, Kasal A, Kocher F, Steiner N, Mazzoleni G, Gastl G, Fong D. INTERNATIONAL JOURNAL OF CANCER: 2016; 139: S. 657-663

BRAF inhibition in hairy cell leukemia with low-dose vemurafenib

Dietrich S, Picher A, Endris V, Peyrade F, Wendtner CM, Follwos GA, Hüllelin J, Jethwa A, Ellert E, Walther T, Liu X, Dyer MJ, Eletr T, Brummer T, Zeiser R, Hermann M, Herold M, Weichert W, Dearden C, Haferlach T, Seiffert M, Hallek M, von Kalle C, Ho AD, Gaehler A, Andruis M, Steurer M, Zenz T.
BLOOD: 2016; 127: S. 2847-2855

Clinical Cancer Research

Clinical evaluation of a Mucorales-specific real-time PCR assay in tissue and serum samples.

Springer J, Lackner M, Ensinger C, Risslegger B, Morton CO, Nachbar D, Lass-Flörl C, Einsele H, Heinz WJ, Loeffler J
JOURNAL OF MEDICAL MICROBIOLOGY: 2016; 65: S. 1414-1421

Treatment With α -1-Antitrypsin for Steroid-Refractory Acute Intestinal Graft-Versus-Host Disease: A Report of 2 Cases.

Gerner RR, Feistritz C, Moschen AR, Kircher B, Moser P, Tilg H, Nachbar D. TRANSPLANTATION: 2016; 100: S. E158-E159

Clinical impact of GATA2 mutations in acute myeloid leukemia patients harboring

CEBPA mutations: a study of the AML study group.
Theis F, Corbacioglu A, Gaidzik VI, Paschka P, Weber D, Bullinger L, Heuser M, Ganser A, Thol F, Schlegelberger B, Göhring G, Köhne CH, Germing U, Brossart P, Horst HA, Haase D, Götze K, Ringhoffer M, Fiedler W, Nachbar D, Kindler T, Held G, Lübbert M, Wattad M, Salih HR, Krauter J, Döhner H, Schlenk RF, Döhner K.
LEUKEMIA: 2016; 30: S. 2248-2250

Prospective multicentre PCR-based Aspergillus DNA screening in high-risk patients with and without primary antifungal mould prophylaxis.

Springer J, Lackner M, Mutschlechner W, Fritz J, Heinz WJ, Einsele H, Ullmann AJ, Löffler J, Lass-Flörl C. CLINICAL MICROBIOLOGY AND INFECTION: 2016; 22: S. 80-86

Rituximab maintenance versus observation alone in patients with chronic lymphocytic leukemia who respond to first-line or second-line rituximab-containing chemoimmunotherapy: final results of the AGMT CLL-8a Maintenance randomized trial.

Greil R, Obrtlíková P, Smolej L, Kozak T, Steurer M, Andel J, Burgstaller S, Mikusova E, Gercheva L, Nösslinger T, Papajik T, Ladicka M, Girschikofsky M, Hrubisko M, Jäger U, Fridrik M, Pechersdorfer M, Králíková E, Burcoveanu C, Spasov E, Petzer A, Mihaylov G, Raynov J, Oexle H, Zabernigg A, Flochova E, Palasthy S, Sthelíková O, Doubek M, Altenhofer P, Pleyer L, Mechlhardt T, Klingler A, Mayer J, Egle A.
LANCET HAEMATOLOGY: 2016; 3: S. E317-E329

Selected Funding

Translational Oncology Group

- **Establishment of a 3D cell culture model to investigate interactions of tumor – stromal co-cultures with immunocompetent cells.** K1 Center ONCOTYROL & Austrian Agency for Advancement of Research (FFG). Project No III. 2.4.PO € 105.000,-
- **Biology of Aging & Personalized Treatment of Elderly Cancer Patients MDS-RIGHT;** Horizon 2020, Grant agreement No 634789, within Personalising health and care program PHC-2014-634789. € 144.000,-
- **TRIAGE-MDS (Translational Implementation of genetic evidence in the management of MDS);** Austrian Science Fund I 1576 within the TRANSCAN ERA Net. € 190.000,-

Biomarkers for Tumor Immunity & Immune Monitoring

- **Intrazellulärer Routineassay zur Detektion der TKI-Wirksamkeit in CML Patienten,** ÖNB Projekt No. 14781 (Prof. Dominik Wolf). € 88.100,-
- **Identification and targeting of ovarian cancer stem cells,** Oncotyrol Project 2.1.8; FFG
- **Improvement of tumor immune therapy by adoptive cell transfer of cb1b-deficient hyperreactive immune cells.** Hertha Firnberg Fellowship (Dr. C. Lutz-Nicoladoni.) Project No T550-B19; € 206.000,-, FWF
- **Patent PCT/EP2015/074797** (GEF Isoforms as cancer stem cell-specific biomarkers and therapeutic targets in ovarian cancer)

Experimental & Clinical Cancer Genomics

- **Genomic profiling of multiple myeloma at diagnosis and disease progression.** Oncotyrol (Dr. W. Willenbacher) Project No 4.4 PO ; € 322.000,-

Collaborations

- Competence Center ONCOTYROL Innsbruck, Austria
- Arbeitsgemeinschaft Tumortherapie (AGMT) Salzburg, Austria
- Austrian Breast and Colon Cancer Study Group (ABCSSG), Vienna, Austria
- Central European Society for Anticancer Research (CESAR) Vienna, Austria
- Mian M, MD, Dept Hematology Bolzano, Italy
- Piccin A, MD PhD, Interdisciplinary Medical Research Center Bolzano, Italy
- Wolf D, MD, Dept. Hematology & Oncology, Bonn University Bonn, Germany
- MDS Net, Duesseldorf University Duesseldorf, Germany
- Arbeitsgemeinschaft Internistische Onkologie (AIO), Berlin, Germany
- Sehouli J, MD, Frauenklinik, Charite Berlin, Germany
- Schweizerische AG für klinische Krebsforschung (SAKK) Bern, Switzerland
- Vesalius Research Center, Leuven, Belgium
- SWG Elderly Task Force in Hematology, Institut Jules Bordet Brussels, Belgium
- De Witte T, European MDS Registry of the ELN Nijmegen, Netherlands
- Jansen J, PhD; Radboud University Medical Center, Nijmegen, Netherlands
- Ossenkoppelle G, MD, University Medical Center Amsterdam, Netherlands
- Porkka K MD; Clinical Hematology, Helsinki University Helsinki, Finland
- CALGB, University of Chicago Chicago, M USA
- Voss Andreas, MD, Caris Life Sciences Inc., C.O.D.E. Phoenix, USA
- Greenberg P, MD, IWG-MDS (International Working Group – MDS) Stanford, USA
- Balducci L, MD, International Society of Geriatric Oncology (SIOG),
- Lee Moffitt Comprehensive Cancer Centre, Tampa, FL, USA
- Klepin H, MD, ASH– Hematology and Aging Special Interest Group,
- Comprehensive Cancer Center of Wake Forest University, Wake Forest, NC, USA
- MD Anderson Cancer Center, Houston, TX, USA

Core Facilities

FACS Sorting Facility (Leader: PD Dr. Sieghart Sopper)
Cell sorting & Multidimensional Flow Cytometry

Joint Institution for Emergency Medicine and Critical Care Medicine



Director:
Univ.-Prof. Dr. Michael Joannidis

Contact:
Anichstraße 35
6020 Innsbruck

Michael.Joannidis@i-med.ac.at
Phone: +43 512 504 24181
Fax: +43 512 504 24199
www.i-med.ac.at/notfallmedizin/

Research Branch (ÖSTAT Classification)

302031

Keywords

Acute kidney injury, sepsis, cardio pulmonary resuscitation, biomarkers, microvesicles, copeptin, plasma pharmacokinetics, target-site pharmacokinetics, pharmacodynamics, antimicrobial agents

Research Focus

- Applied clinical as well as bench-to bedside research covering several aspects of critical illness with special emphasis on acute kidney injury (AKI), sepsis, and cardiopulmonary resuscitation (CPR)
- Definition and clinical validation of biomarkers for diagnosis and prognosis of AKI and CPR
- Identification and characterisation of microvesicles in severe sepsis
- Intensive care specific pharmacodynamics and pharmacokinetics

General Facts

The Joint Institution/Division of Medical Intensive Care and Emergency Medicine was established in December 2012. Clinically, it was designed as a core facility for the Department of Internal Medicine, providing a high level of Intensive Care and Emergency Medicine. It comprises a level three intensive care unit and the medical emergency room including a short stay (maximum 24 hours) ward located in the Medizinzentrum Anichstraße (MZA). Ad-

ministratively, the unit is affiliated to the Department of Internal Medicine I (Director: Prof. Dr. Herbert Tilg).

The unit is involved in several clinical multicentre trials investigating early diagnosis and treatment of acute kidney injury, treatment of severe infections and sepsis as well as antimicrobial pharmacokinetics. Complementary *in vitro* models are used to investigate inflammatory mechanisms of renal injury.

The research unit comprises the Laboratory of Inflammation Research (U-1-015) hosting two research groups: the Intensive Care Medicine group (Anna Brandtner, Julia Hasslacher, Viktoria Haller, Sebastian Klein, Georg Lehner, Alexander Magnutzki, Birgit Zassler) led by Michael Joannidis and the Clinical Pharmacokinetics group (Rene Welte, Tiziana Gasperetti) led by Romuald Bellmann.

Collaboration partners include all University Clinics (I-V) of the Department of Internal Medicine, the Neurological Intensive Care Unit and the Surgical/Trauma Intensive Care Unit as well as the Division of Hygiene and Medical Microbiology and the Division of Molecular and Cellular Pharmacology.

Research

Intensive Care Medicine

Michael Joannidis

This group is involved in clinical research in critical illness with a major interest in acute kidney injury and cardiopulmonary resuscitation. A second major focus is

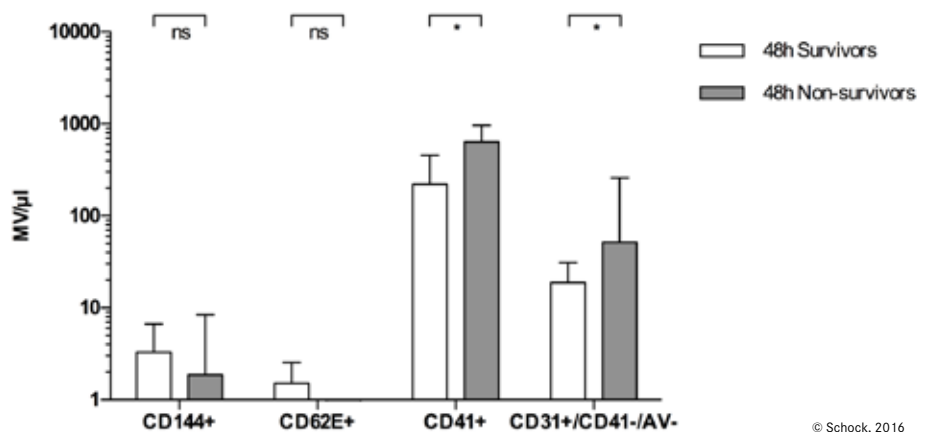

Fig. 1: Characterisation of microvesicles in septic shock, by applying high-sensitivity flow cytometry (0.3 µm resolution): Comparison of endothelium- (CD144+, CD62E+) MV, platelet- (CD41+) and presumably leukocyte-derived MV (CD31+/CD41-/AnnexinV-) in patients with septic shock who survived or did not survive 48h after blood was drawn.

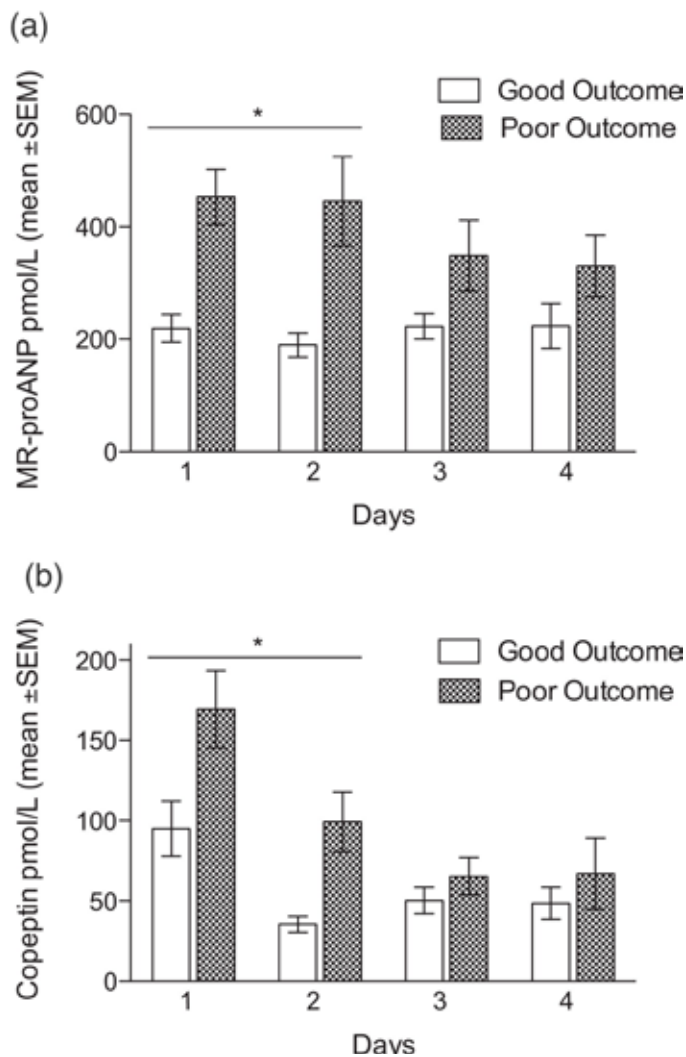

Fig. 2: Course of a) MR-proANP and b) Copeptin dichotomised between good (CPC 1-2) and poor outcome (CPC 3-5). CPC - cerebral performance category, *indicates significant difference between outcome groups (good versus poor outcome, Student's T-test, $p < 0.05$).

investigation of microvesicles in sepsis.

Acute Kidney Injury (AKI)

AKI in the critically ill is associated with significant mortality and long term morbidity including end stage renal disease. This was clearly demonstrated by the AKI-EPI study, the largest prospective observational study, which indicated an incidence of AKI above 50%. We also participated in several other multicentre trials investigating biomarkers for AKI: The SAPHIRE and OPAL study defined and evaluated the cell cycle arrest proteins TIMP-2 and IGFBP-7 as early predictors of AKI with an unprecedented sensitivity and specificity. This was followed by the international multicentre RUBY study which tested TIMP-2 and IGFBP-7 and other biomarkers with regard to their capability to predict recovery from AKI. In a complemen-

tary approach we are currently investigating the effect of cell cycle arrest on cellular recovery from damage as well as reversibility of cell cycle arrest after relief from cell stress after a defined insult *in vitro* using an endo-epithelial co-culture system. Finally we participated in the design and execution the first prospective placebo controlled randomised controlled trial testing alkaline phosphatase for reducing severity and duration of sepsis associated AKI (STOP-AKI). Its results will be available in 2017.

Microvesicles in Severe Sepsis and Septic Shock

Severe sepsis has a worldwide annual incidence of around 3/1000 inhabitants and a mortality rate $> 50\%$ when proceeding to septic shock. This syndrome is frequent-

ly complicated by devastating coagulation disturbances leading to disseminated intravascular coagulation (DIC). Microvesicles (MV) are capable of mediating pleiotropic inflammatory signals during sepsis and may play a key role in the propagation of thrombin generation via phosphatidylserine exposure as well as in the initiation of blood coagulation by specific epitopes such as tissue factor. In a prior project funded by the OeNB Anniversary Fund, we developed a specific high-sensitivity flow cytometry approach which enabled us to measure previously undetectable smaller MV down to $0.3\ \mu\text{m}$ diameter. Using this approach we found that increased levels of MV detected in patients with septic shock predominantly originate from circulating cells, indicating excessive leukocyte and platelet activation rather than MV release from damaged endothelia. This effect was even more enhanced in lethal septic shock (figure 1).

Secondly, we could demonstrate that MV are not eliminated by CRRT, but that the contact of blood with artificial membranes leads to further release of platelet- and leukocyte-derived MV, indicating a further proinflammatory stimulus by extracorporeal treatment. These results triggered a subsequent project funded by the OeNB (anniversary funds project 15708) in which we are investigating the role of MV in activating the coagulation in sepsis. We successfully established specific coagulation assays which allowed us to investigate the interactions between MV, the endothelium and the coagulation system in a translational approach. The results indicate a crucial role of the endothelium-mediated activation of the coagulation system by MVs carrying tissue factor.

Hypoxic Brain Damage after Cardiopulmonary Resuscitation (CPR)

Cardiac arrest is one of the major causes of death in cardiovascular disease, frequently associated with long-term neurological deficits in case of survival. In 2014 secretoneurin was identified by our research group as a very sensitive and robust biomarker predicting unfavourable neurological outcome after CPR. In a subsequent study we analysed the additional biomarkers MRproANP and copeptin in the same cohort of 150 consecutive patients admitted to our ICU after successful CPR (figure 2). Though showing acceptable prediction of outcome their performance was clearly inferior to secretoneurin with regard to being influenced by therapeutic hypothermia or haemolysis. A further investigation

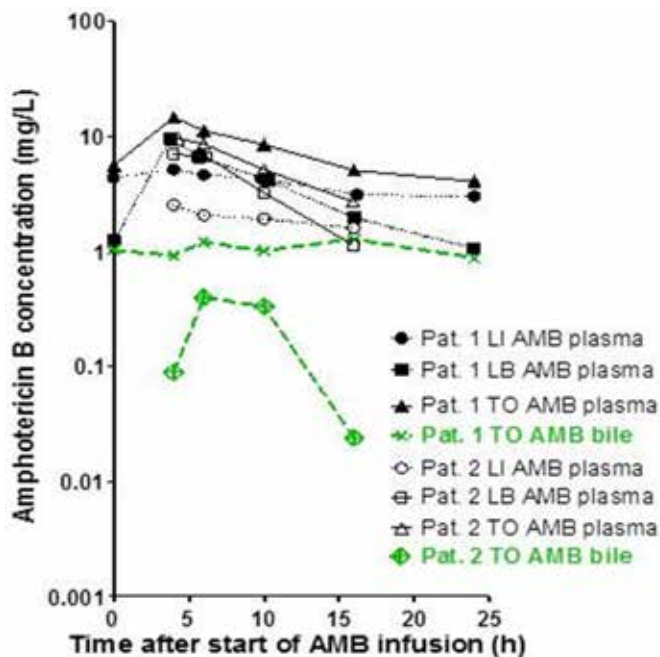

© Int J Antimicrob Agents, 2015

Fig. 3: Amphotericin B levels in bile and plasma: in bile, total amphotericin B levels have been measured (green lines) after standard dose of liposomal amphotericin B at steady state. In plasma, amphotericin B that had been liberated for lipid-encapsulation (LI AMB), Lipid-bound amphotericin B (LB AMB), and total amphotericin B (TO AMB) were separately determined.

of the performance of the well-established biomarker neuron specific enolase (NSE), combining our patients with those of four other centres, resulted in the currently largest cohort of 1053 patients after successful CPR and found a higher threshold of 90 $\mu\text{g/l}$ for reliable prediction of unfavourable neurological outcome in patients treated with mild therapeutic hypothermia. The manuscript will appear in early 2017.

Major Achievements:

- 1) Clinical validation of cell cycle arrest proteins as biomarkers for AKI and renal recovery.
- 2) Establishment of high-sensitivity flow cytometric MV analysis and characterisation of circulating MV as being mainly platelet and leucocyte derived in septic shock; use of extracorporeal systems seems to enhance this effect rather than eliminate MV.
- 3) Identification and evaluation of secretoneurin, MRproANP and copeptin as early predictors for severe hypoxic brain damage.

Future Directions:

- 1) Investigating clinical interventions attenuating AKI and stimulating renal recovery in critically ill patients.

- 2) Investigating specific effects of MV subtypes on distinct proteolytic processes of the coagulation system in DIC.
- 3) Definition of biomarker panels for neurologic outcome prediction after CPR.

Clinical Pharmacokinetics

Romuald Bellmann

Severe infections are a common reason for critical illness. Adequate antimicrobial chemotherapy is crucial for the clinical outcome. Sub-therapeutic antimicrobial dosage results in poor response and may promote the emergence of resistant microorganisms. On the other hand, critically ill patients are at an enhanced risk of drug toxicity. Absorption, distribution, metabolism and elimination of drugs can be altered by critical illness depending on the state of disease, type of organ failure and the required treatment modality. An increasing number of patients present with profound immunological dysfunction, facilitating infections by opportunistic pathogens such as invasive fungal infections associated with a mortality rate exceeding 50%. Optimal choice and dosage of antifungal agents, guided by pharmacokinetic and pharmacodynamic considerations, will improve the clinical outcome.

Since most infections occur in tissue rather than in the blood stream, target-site pharmacokinetics might be even more relevant for clinical outcome than plasma pharmacokinetics. Biliary Candida infections are a particular therapeutic challenge. Therefore, biliary AMB pharmacokinetics in patients treated with lipid-formulated AMB and biliary AMB pharmacodynamics by *in vitro* and *ex vivo*-simulations were investigated. Biliary AMB concentrations were lower and displayed a slower rise and decline than plasma levels (figure 3). Fungal growth and AMB activity were impaired by bile. Thus, treatment of fungal cholangitis with lipid-formulated AMB is not supported by our data.

Whereas echinocandins are highly active against candidaemia, their efficacy against deep-seated or disseminated Candida infections is less clear and data on their target-site pharmacokinetics is sparse. Although echinocandins are relatively safe, micafungin caused foci of altered hepatocytes (FAH) in rats. Therefore, we have started a project on quantification of echinocandins in various human body fluids and tissues which is supported by the Austrian Research Funds FWF (project no. KLI 565-B31). Assessment of echinocandin pharmacokinetics and antifungal efficacy in body fluids, as well as detection of FAH in human liver, are further objectives. Ten ICUs in 5 Austrian centres are participating in this project and will include 138 critically patients providing up to ~1,000 blood and body fluids samples. In addition, tissue samples will be taken during routine autopsies from 30 patients who have died after echinocandin treatment.

Major Achievements: Determination of target site kinetics of lipid-formulated AMB in critically ill patients.

Future Goals: Plasma and target-site pharmacokinetics and pharmacodynamics of echinocandins and of trimethoprim sulfonamide combinations.

Selected Publications

Characterization of Microvesicles in Septic Shock Using High-Sensitivity Flow Cytometry

Lehner, Georg Franz, Harler, Ulrich, Haller, Viktoria Maria, Feistritzer, Clemens, Hasslacher, Julia, Dunzendorfer, Stefan, Bellmann, Romuald, Joannidis, Michael,
SHOCK: 2016; 46: S. 373-381

Study protocol for a multicentre randomised controlled trial: Safety, Tolerability, efficacy and quality of life Of a human recombinant alkaline Phosphatase in patients with sepsis-associated Acute Kidney Injury (STOP-AKI)

Peters, Esther, Mehta, Ravindra L., Murray, Patrick T., Hummel, Jurgen, Joannidis, Michael, Kellum, John A., Arend, Jacques, Pickkers, Peter,
BMJ OPEN: 2016; 6: S. e012371

Epidemiology of acute kidney injury in critically ill patients: the multinational AKI-EPI study

Hoste, Eric A. J., Bagshaw, Sean M., Bellomo, Rinaldo, Cely, Cynthia M., Colman, Roos, Cruz, Dinna N., Edipidis, Kyriakos, Forni, Lui G., Gomersall, Charles D., Govil, Deepak, Honore, Patrick M., Joannes-Boyau, Olivier, Joannidis, Michael, Korhonen, Anna-Maija, Lavrentieva, Athina, Mehta, Ravindra L., Palevsky, Paul, Roessler, Eric, Ronco, Claudio, Uchino, Shigehiko, Vazquez, Jorge A., Vidal Andrade, Erick, Webb, Steve, Kellum, John A.,
INTENSIVE CARE MEDICINE: 2015; 41: S. 1411-1423

Outcome prediction and temperature dependency of MR-proANP and Copeptin in comatose resuscitated patients

Broessner, Gregor, Hasslacher, Julia, Beer, Ronny, Lackner, Peter, Lehner, Georg Franz, Harler, Ulrich, Schiefecker, Alois, Helbok, Raimund, Pfausler, Bettina, Hammerer-Lercher, Angelika, Joannidis, Michael,
RESUSCITATION: 2015; 89: S. 75-80

Biliary amphotericin B pharmacokinetics and pharmacodynamics in critically ill liver transplant recipients receiving treatment with amphotericin B lipid formulations

Welte, Rene, Eschertzhuber, Stephan, Weiler, Stefan, Leitner-Rupprich, Sandra, Aigner, Maria, Lass-Floerl, Cornelia, Stienecke, Eva, Bellmann-Weiler, Rosa, Joannidis, Michael, Bellmann, Romuald,
INTERNATIONAL JOURNAL OF ANTIMICROBIAL AGENTS: 2015; 46: S. 325-331

Selected Funding

- Interaction between microvesicles, endothelium and the coagulation system in sepsis and DIC, OeNB Anniversary Fund (project 15708), Michael Joannidis
- Target-Site Pharmacokinetics and -Activity of Echinocandins, Austrian Research funds FWF (Project KLI 565-B31), Romuald Bellmann

Collaborations

- Univ. Prof. Dr. Thomas Staudinger, Intensive Care Unit, Internal Medicine I, Medical University Vienna, Vienna, Austria
- Professor Stefan Kluge, Department of Intensive Care Medicine, Hamburg Eppendorf, Hamburg, Germany
- Prim. Univ.-Prof. Dr. Christian Wiedermann, Department of Internal Medicine, Central Hospital of Bolzano, Bolzano, Italy
- John Kellum, MD, FCCM, FACP, University of Pittsburgh School of Medicine, Pittsburg, PA, USA
- Ravindra L. Mehta, MD, UCSD Medical Centre, San Diego, CA, USA
- Univ.-Prof. Dr. Jaroslav Sterba, Department of Pediatric Oncology, University Hospital Brno and Masaryk University, Brno, Czech Republic
- Dr. Piotr Smuszkiewicz, Department of Anesthesiology, Intensive Therapy and Pain Treatment, University Hospital Przybyszewskiego, Poznan, Poland
- Univ.-Prof. Dr. Markus Müller und Priv. Doz. Dr. Markus Zeitlinger, Universitätsklinik für Klinische Pharmakologie, AKH, Wien

Psychiatry I



Director:
**Univ.-Prof. Dr. W. Wolfgang
Fleischhacker**

Contact:
Anichstraße 35
6020 Innsbruck

Wolfgang.Fleischhacker@i-med.ac.at
Phone: +43 512 504 23669
Fax: +43 512 504 25267
[https://psychiatrie.tirol-kliniken.at/
page.cfm?vpath=psychiatrie-i](https://psychiatrie.tirol-kliniken.at/page.cfm?vpath=psychiatrie-i)

Research Branch (ÖSTAT Classification)

302038, 302045, 302046,
302065, 302066

Keywords

Bio-psycho-social aspects of diseases,
doctor-patient-relationship, psychotherapy

Research Focus

- Alcoholism
- Alzheimer's disease
- Drug safety
- Patient related outcomes
- Psychopharmacology
- Schizophrenia
- Substance use disorder
- Suicide disorders

General Facts

Embedded in the clinical services of the center, the research groups in the Department of Psychiatry I have a long standing tradition of dealing with a host of different topics related to various aspects of psychiatry. They are supported by a number of international collaborators and funded by grants from the European Union, the Austrian Science Foundation, the European Organisation for Research and Treatment in Cancer (EORTC), the European Group for Research in Schizophrenia and the pharmaceutical industry, the latter through both investigator initiated grants as well as classical industry sponsored phase II and phase III trials. In addition, international collaborators include Keio University in Tokyo, the University of Bergen in Norway, Icahn School of Medicine at Mount Sinai and Zucker Hillside Hospital in New York as well as local collaborators within the Department and also other medical disciplines of the Medical University Innsbruck.

Research

Age Related Psychiatric Disorders

*Michaela Defrancesco, Eberhard
Deisenhammer, Bernhard Holzner,
Imrich Blasko*

This research group has its main base in the Memory Clinic of the Department. In addition to providing clinical service for the catchment area, specific areas of scientific interest include the neuropsychological and anatomical underpinnings of mild cognitive impairment (MCI) and Alzheimer dementia. In this context, a strong emphasis is given to possible predictors for the conversion from

MCI to dementia. To this end, next to findings from well-established neuropsychological tests, anatomical imaging findings and both peripheral and central biomarkers are explored. The Departments of Neuroradiology, the Department of Psychiatry and Psychotherapy A, Hall State Hospital and the Laboratory for Experimental Alzheimer Research are important collaborating partners. Next to that, Dr. Defrancesco is a board member of the Austrian Alzheimer Society (ÖAG) and her research group takes part in the national multi-centric cohort study PRODEM-Austria.

In addition, they participate in local as well as regional projects in the field of dementia care (Demenz braucht Kompetenz, Tirol Kliniken), studies dealing with various physical, cognitive and social activities as possible risk or protective factors for dementia (GERDA, TGF project). Under the leadership of Imrich Blasko the group participates in a phase 2 study to assess the safety and efficacy of active immunisation against phosphorylated tau protein in patients with mild Alzheimer's disease.

The driving ability of the elderly is a research topic studied in collaboration with Ilsemarie Kurzthaler, who leads the Department's traffic safety in psychiatry group.

Behavioral and Clinical Psychology

Verena Günther

Behavioural and Clinical Psychology focuses primarily on cognitive/behavioural aspects of chronically ill patients (e.g. body image in patients with an insulin pump, psychological aspects of patients with an implantable cardioverter defibrillator) and on the conceptualization and evaluation of stigma-management-programs and cognitive training programs in psychiatric patients.

Health psychology aims to evaluate our nicotine cessation program and focusses on aspects of body image and body modification (eg in blind people).

Consultation/Liaison Service, Quality of Life, Outcomes Research

Bernhard Holzner

In close collaboration with the Department of Psychosomatics, this group investigates the impact of disease and treatment on the subjective health status of chronic somatically ill patients. This is done by the application of late breaking statistical (item response theory) and technical methodology (web-based questionnaire data collection).

The group is developing item banks and computer-adaptive questionnaires in order to tailor the questions selected by a sophisticated CAT algorithm to the respective health status of the patient. This leads to maximizing measurement precision and minimizing patients' burden. Furthermore, the study group is also developing patient portals for web-based home-monitoring of patients.

Some of this work is done under the aegis of EORTC and with support from the oncology units in the Departments of Haematology and Gynaecology of the MUI.

Experimental Alzheimer Research

Christian Humpel

In close collaboration with the clinical researchers, research in the Laboratory of Experimental Alzheimer's disease focusses on investigating the development of beta-amyloid plaques in Alzheimer's disease. In an EU project the effect of protective and regenerative biomaterials (collagen scaffolds) on dopaminergic and cholinergic neurons in organotypic brain slices is being studied. Furthermore, the role of platelets in the progression of cerebral amyloid angiopathy is explored. Another research focus is to find and establish novel biomarkers in blood to diagnose Alzheimer's disease. In addition to peripheral markers, this lab also scientifically evaluates routinely acquired CSF samples from patients referred either from the Memory Clinic or from the inpatient units of the Department.

Experimental Psychiatry Unit

Alois Saria, Gerald Zernig

The Experimental Psychiatry Unit is one of the host labs for the international PhD program "Signal Processing in Neurons". Research at the lab focusses on the mechanisms of reward and the mode of action of psychoactive drugs. In addition, the lab offers clinical service for psychiatric patients, i.e. Therapeutic Drug Monitoring (TDM). In this context, blood levels of over 30 antidepressant or antipsychotic drugs are determined daily for the University Hospital Innsbruck and for additional hospitals and physicians in Austria and Northern Italy, by use of liquid chromatography-tandem mass spectrometry. TDM results are also exploited for addressing various research questions, and the lab is the core laboratory for drug monitoring in two large European multicentre studies (OPTiMiSE and EU-LAST).

The Experimental Psychiatry Unit is also

a partner in the Human Brain Project, one of the two flagship research projects funded by the European Commission, involving over 100 partner universities in Europe and some outside Europe. Alois Saria leads the "Education Program" of this project to coordinate education and training of a large number of PhD students in this multidisciplinary project.

Addiction Research, Preclinical

Gerald Zernig

Impaired social interaction is a hallmark symptom of many psychiatric diseases including substance dependence. Gerald Zernig's group studies the neural basis of a reorientation away from cocaine as a prototypical drug of abuse toward dyadic (i.e., one-to-one) social interaction using, e.g., gSTED (gated Stimulated Emission Depletion) microscopy of immunofluorescently labelled neurons, dendritic morphology change analysis, transgenic mouse models (drd1cre, creTVA), and the modulation of gene expression by stereotaxic delivery of transcription vectors. Zernig also investigates power abuse disorder as a non-drug dependence syndrome.

Schizophrenia Research

Wolfgang Fleischhacker, Alex Hofer

Clinical Psychopharmacology

Past and ongoing studies focus on antipsychotics, ranging from early drug development in phase II clinical trials all the way to large-scale international pragmatic effectiveness studies. The underlying theme is always enhancing treatment options for patients with schizophrenia. The European First Episode in Schizophrenia Trial (EU-FEST) and the Optimization of Treatment and Management of Schizophrenia in Europe (OPTiMiSE) were the first large-scale independent comparative first episode studies worldwide, evaluating treatment outcomes in 14 European countries and Israel. Currently, the European Long-acting Antipsychotics in Schizophrenia Trial (EU-LAST) pursues related research questions with advanced methodology

The group is also involved in global efforts to improve clinical trial design in order to ease the translation from rigorous randomized controlled clinical trial standards into every day clinical practice. In this context, the issues of treatment attitudes, compliance and drug safety have been given particular emphasis, a prospective therapeutic drug monitoring program in schizophrenia patients treated with new generation antipsy-

chotics being one example of these efforts.

Cognition

Both neuro- and social cognition present another focus of this research group. More recently, the investigation of social cognition in symptomatically remitted patients suffering from serious mental illness has received much attention. To this end, a number of studies investigating Emotional Intelligence have been conducted in patients suffering from schizophrenia or bipolar disorder, their unaffected siblings as well as healthy control subjects, to identify social cognitive deficits as potential trait markers for these disorders.

Resilience

A number of studies investigated resilience and its biological correlates in patients with schizophrenia and bipolar disorder with a focus on religion and culture. The primary aim of these studies was to investigate trans-cultural differences in resilience across patients from two different geographical regions, Austria and Japan that have different religious and cultural backgrounds (i.e. Christianity and Buddhism).

Another study investigates the degree and quality of resilience as well as its correlates (e.g. hope, self-esteem, social support) across students from local universities. Using 3 T-MRI and fMRI and focusing on sex differences, we are currently examining potential structural and functional cerebral differences in subjects with a high degree of resilience compared to subjects with a low degree of resilience in close collaboration with the Department of Neurology.

Substance Use Disorder, Clinical

Sergei Mechtcheriakov, Claudia Rupp

A 27 bed alcohol rehabilitation inpatient unit as well as a large outpatient clinic for patients suffering from substance-related and addictive disorders from the illegal spectrum are the base for research in this clinical field. Much emphasis is devoted to neuropsychological deficits in patients suffering from alcohol use disorder and their impact on the development and maintenance of this chronic, relapsing disease as well as their relevance with respect to treatment outcomes. Individually tailored neuropsychological interventions complement structured treatment programs.

The effects of chronic alcohol intake on immune system, kynurenine metabolism and bone metabolism are other areas of interest in this research group. With respect to

illegal drugs, patients in opioid maintenance treatment programs constitute a large group of interest. Currently, preferences for the different drugs available in substitution programs and the relevance of subjective attitude are studied.

Suicide and Affective Disorders

Armand Hausmann, Eberhard Deisenhammer

A continuing focus of the research activities of this group in 2016 was suicide, in particular in association with hospitalization. The final stage of a major project on in-patient and post-discharge suicides started with the first publication. Another paper on the stability in the choice of method during the period preceding a suicide attempt was also published. We finalized a project on decision making behavior in suicide attempters, the manuscript of which is currently under review. Further research activities included the association between resilience and suicidal behaviour/ideation and colour identification in depression.

Three book chapters for the Austrian 2017 depression report were prepared. Topics were gender-specific differences in depression, differential efficacy between pharmacological and psycho-therapeutical interventions in depression as well as a chapter on patient centred care in depression. One of the reviews rules out differences between early- and late-onset bipolar disorder. The second depicts renal side effects of lithium in old age.

Selected Publications

Thiazine Red(+) platelet inclusions in Cerebral Blood Vessels are first signs in an Alzheimer's Disease mouse model

Kniewallner, Kathrin M., Wenzel, Daniela, Humpel, Christian, SCIENTIFIC REPORTS: 2016; 6: S. 28447

The use of EORTC measures in daily clinical practice-A synopsis of a newly developed manual

Wintner, Lisa M., Sztankay, Monika, Aaronson, Neil, Bottomley, Andrew, Giesinger, Johannes M., Groenvold, Mogens, Petersen, Morten Aa, van de Poll-Franse, Lonke, Velikova, Galina, Verdonck-de Leeuw, Irma, Holzner, Bernhard, EORTC Quality Life Grp, EUROPEAN JOURNAL OF CANCER: 2016; 68: S. 73-81

Impulsivity and Alcohol Dependence Treatment Completion: Is There a Neurocognitive Risk Factor at Treatment Entry?

Rupp, Claudia I., Beck, J. Katharina, Heinz, Andreas, Kemmler, Georg, Manz, Sarah, Tempel, Katharina, Fleischhacker, W. Wolfgang, ALCOHOLISM-CLINICAL AND EXPERIMENTAL RESEARCH: 2016; 40: S. 152-160

Dyadic social interaction of C57BL/6 mice versus interaction with a toy mouse: conditioned place preference/aversion, substrain differences, and no development of a hierarchy

Pinheiro, Barbara S., Seidl, Simon S., Habazettl, Eva, Gruber, Bernadette E., Bregolin, Tanja, Zernig, Gerald, BEHAVIOURAL PHARMACOLOGY: 2016; 27: S. 279-288

Dyadic social interaction inhibits cocaine-conditioned place preference and the associated activation of the accumbens corridor

Zernig, Gerald, Pinheiro, Barbara S., BEHAVIOURAL PHARMACOLOGY: 2015; 26: S. 580-594

Changes in psychopathology in schizophrenia patients starting treatment with new-generation antipsychotics: therapeutic drug monitoring in a naturalistic treatment setting

Kaufmann, Alexandra, Wartelsteiner, Fabienne, Yalcin-Siedentopf, Nursen, Baumgartner, Susanne, Biedermann, Falko, Edlinger, Monika, Kemmler, Georg, Rettenbacher, Maria A., Rissanen, Tanja T., Widschwendter, Christian G., Zernig, Gerald, Fleischhacker, W. Wolfgang, Hofer, Alex, EUROPEAN NEUROPSYCHOPHARMACOLOGY: 2016; 26: S. 717-728

The Two Faces of Social Interaction Reward in Animal Models of Drug Dependence

El Rawas, Rana, Saria, Alois, NEUROCHEMICAL RESEARCH: 2016; 41: S. 492-499

Social interaction reward decreases p38 activation in the nucleus accumbens shell of rats

Salti, Ahmad, Kummer, Kai K., Sadangi, Chinmaya, Dechant, Georg, Saria, Alois, El Rawas, Rana, NEUROPHARMACOLOGY: 2015; 99: S. 510-516

Selected Funding

Experimental Psychiatry Unit

- Austrian Science Fund W1206 - Graduate School: Signal Processing in Neurons (PI: Gerald Zernig)
- Austrian Science Fund P26248: Social interaction as an alternative to cocaine (PI: Gerald Zernig)
- Austrian Science Fund P 27852-B21: Does social interaction have an anti-stress effect? (PI: Rana El Rawas)
- Austrian Science Fund T758-BBL : Drug reward and natural reward are mediated by different intracellular pathways
- European Commission FP7-ICT-2013-FET-F: Human Brain Project (PI: Alois Saria)

Group Humpel:

- BrainMatTrain project is funded by the European Union Horizon 2020 Programme (H2020-MSCA-ITN-2015) under the Marie Skłodowska-Curie Initial Training Network and Grant Agreement No. 676408
- Austrian Nationalbank Jubiläumsfonds (Nr. 15887)
- Austrian Science Funds P24541-B24

Collaborations

- Andreas Frick, Université de Bordeaux, France
- Scott J Russo, Mount Sinai School of Medicine, NY, NY, USA
- Charles Gerfen, NIMH, NIH, Bethesda, MD, USA
- Michael T Bardo, University of Kentucky, Lexington, KY, USA

Psychiatry II



Director:
Univ.-Prof.ⁱⁿ Dr.ⁱⁿ Barbara Sperner-Unterweger

Contact:
Anichstraße 35
6020 Innsbruck

barbara.sperner-unterweger@i-med.ac.at
Phone: +43 512 504 23691
Fax: +43 512 504 24778
<https://psychiatrie.tirol-kliniken.at/page.cfm?vpath=psychiatrie-ii>

Research Branch (ÖSTAT Classification)

301408, 301905, 302046,
302065, 302067

Keywords

Psychophysiology, stress, depression, eating disorders, patient-reported outcomes,

Research Focus

- Interdisciplinary psycho-somatic research: using the field of „psychophysiology“ to study psycho-somatic and somato-psychic comorbidities:
- Research of stress related disorders
- Research of eating disorders
- Research of patient reported outcomes

General Facts

Research in the field of psychosomatic medicine is interested in the complex interaction of the following:

- physical, mental, and social conditions contributing to health and disease
- somatic and mental health problems resulting in psycho-somatic and somato-psychic comorbidities

This Research is characterized by interdisciplinary approaches

- in cooperation with the Psychiatric/ Psychotherapeutic Consultation-Liaison Service
- in cooperation with other clinical units outside the Department of Psychiatry, Psychotherapy and Psychosomatic.

We consider the “patient’s perspective” of major importance in the clinical setting as

well as in psychosomatic research. Most of our research projects directly or indirectly involve the subjective judgement of the individual patient regarding his/her own mental and physical well-being.

Research

Research in Stress Related Disorders

Psychoimmunology as a discipline studies the interaction of psychological processes, the nervous system, and the immune system. Stress is thought to be a major mediator in this circle leading to psycho-somatic and somato-psychic comorbidities. We investigated changes in neurotransmitter precursor amino acids (kynurenine, phenylalanine, tyrosine, tryptophan) in patients with depression and/or breast cancer and healthy controls and we were able to show that levels of neurotransmitter precursor amino acids correlate with mental health scores; this was much more evident in patients with breast cancer than in those without (Fig. 1).

Platelets are sometimes used as a model in this context because they contain many receptors and transmitters that are also found in the brain. Furthermore, they contain immunologically active compounds. We showed that platelet bioactivity is influenced by chronic stress in healthy individuals and is also altered in depressed subjects. We are currently investigating healthy individuals as well as patients with depression and depressive adjustment disorders and are evaluating their platelet function in chronic and acute mental stress conditions. These projects are supported by an ongoing ÖNB grant (Platelet function as biomarker

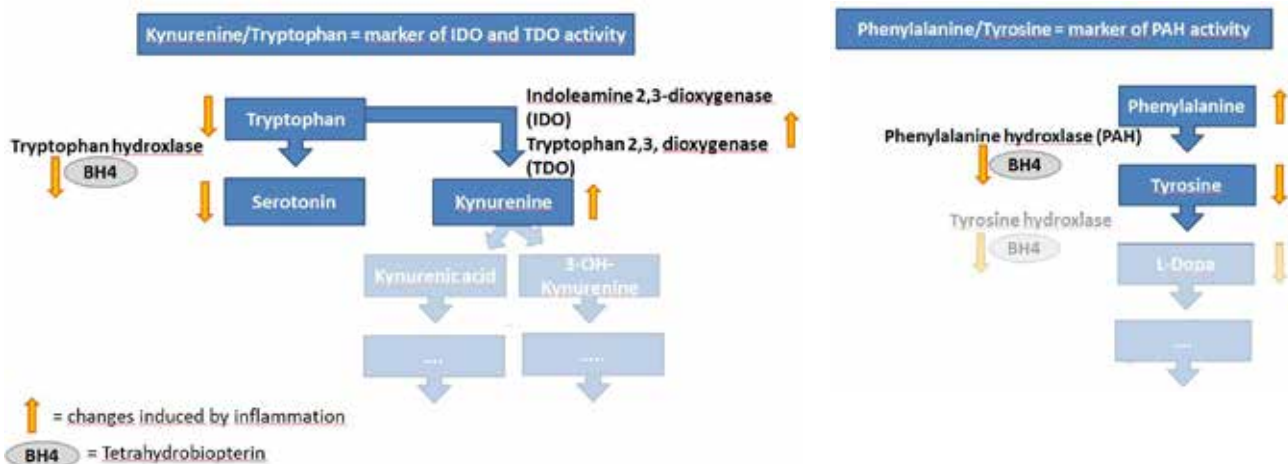

Fig. 1: Graphical depiction of the amino acid derived neurotransmitter biosynthesis pathways analyzed in our current studies. Changes induced by inflammation are indicated with an arrow.

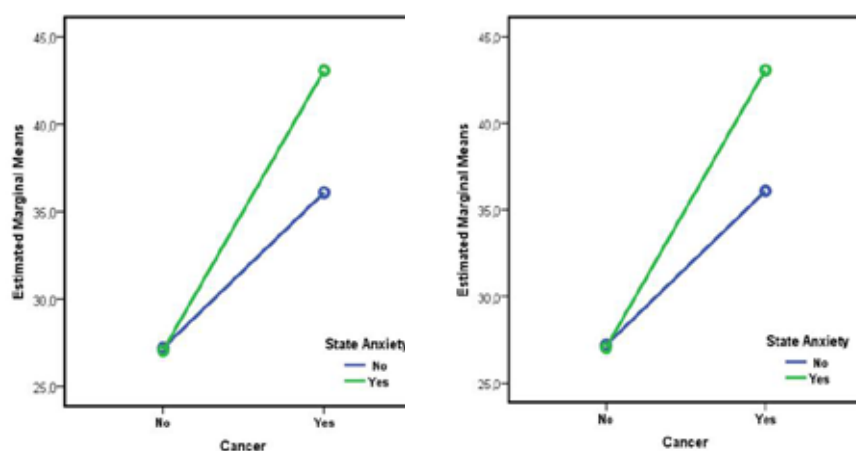

Fig. 2: Results of the interaction of breast cancer with depression on PHE/TYR ratio (A) and of breast cancer and state anxiety on KYN/TRP (B). The interactions demonstrate an effect of psychological distress on neurotransmitter precursor amino acids in patients with breast cancer, which is less evident in physical healthy subjects.

of depression - Can acute mental stress increase the diagnostic value?; 01.01.2013 - ongoing).

Research in Eating Disorders

Present research is focused on various aspects of clinical eating disorders; currently we are researching the following topics:

- addictive symptoms in anorexic and bulimic patients,
- gender specific differences in bariatric patients
- eating pathology in middle aged and older men

In a study of 470 men in and around Innsbruck, 32 (6.8%) reported having symptoms of an eating disorder. The 32 men with eating disorder symptoms, compared to the 438 men presenting normal eating, showed a significantly greater pathology on scales which are used to assess eating behaviours, exercise habits, addiction, satisfaction with one's body shape, and body weight.

Patient-reported Outcome and Health Technology Assessment

One of the major research focuses of our group in 2015 and 2016 was the evaluation of medical treatments and the impact of chronic diseases from the patient's perspective. We have conducted a number of patient-reported outcome (PRO) studies in cancer and orthopaedic patients investigating clinical, as well as methodological research questions with a focus on quality of life parameters. Our most important contributions in the field of PRO and health technology assessments were to show that PRO monitoring is feasible in different

somatic settings, which is widely accepted by patients and staff alike; and, that graphical questionnaire outputs are mostly well understood by patients and their attending physicians. Furthermore, we extended our PRO research activities beyond oncology and orthopaedics and are currently conducting studies in psychosomatic medicine dealing with in- and outpatients of the Division of Psychiatry II. At the moment we are scientifically monitoring the integration of PRO research into routine psychosomatic patient care and are planning on assessing the impact of PRO monitoring on medical interventions.

Beyond clinical studies the research group is also engaged in conducting methodological projects, for example, by developing computer-adaptive instruments for more accurate and efficient evaluations of PRO constructs, as well as by validating the use of the international cancer specific utility instrument called EORTC QLU-10D in cost effectiveness trials in the future.

Selected Publications

Cost-utility analyses of drug therapies in breast cancer: a systematic review.

Nerich V, Saing S, Gamper EM, Kemmler G, Daval F, Pivot X, Holzner B. BREAST CANCER RESEARCH AND TREATMENT: 2016; 159:407-24.

The use of EORTC measures in daily clinical practice. A synopsis of a newly developed manual.

Wintner LM, Sztankay M, Aaronson N, Bottomley A, Giesinger JM, Groenvold M, Petersen MA, van de Poll-Franse L, Velikova G, Verdonck-de Leeuw I, Holzner B; EORTC Quality of Life Group. EUROPEAN JOURNAL OF CANCER:2016; 68: S. 73-81

Thresholds for clinical importance for four key domains of the EORTC QLQ-C30: physical functioning, emotional functioning, fatigue and pain.

Giesinger JM, Kuijpers W, Young T, Tomaszewski KA, Friend E, Zubernig A, HEALTH AND QUALITY OF LIFE OUTCOMES: 2016; 14: S. 87

Evaluation of electronic patient-reported outcome assessment with cancer patients in the hospital and at home.

Wintner LM, Giesinger JM, Zubernig A, Rumpold G, Sztankay M, Oberguggenberger AS, Gamper EM, Holzner B. BMC MEDICAL INFORMATICS AND DECISION MAKING: 2015;15:S. 110.

Selected Funding

Development of an EORTC questionnaire for individuals at risk for a Hereditary Cancer Predisposition Syndrome: the EORTC QLQ-HCPSxx, Agency: EORTC.;Grantee: Medical University Innsbruck (Principal Investigator: Mag. Dr. Anne Oberguggenberger),

Platelet function as biomarker of depression - Can acute mental stress increase the diagnostic value? Österreichische Nationalbank, 01.01.2013 -extended till 31.12.2017

Collaborations

- Harrison G. Pope, MD; Biological Psychiatry Laboratory, McLean Hospital/Harvard Medical School, Boston, USA
- Hans W. Hoek, MD; Parnassia Psychiatric Institute, The Hague/Department of Psychiatry, Groningen University, The Netherlands / Department of Epidemiology, Columbia University, New York, USA
- Dr. K.M. Giesinger; Kantonsspital St. Gallen (Dept. of Orthopedics), St. Gallen, Schweiz
- Univ.-Prof. Dr. Henning Flechtner; Magdeburg University Hospital
- Univ.-Prof. Dr. Susanne Singer; Leipzig University Hospital (Stepped care project)
- Prof. Dr. Fabio Efficace, GIMEMA Group, Roma, Italy

Medical Psychology



Director:
o. Univ.-Prof. Dr. Gerhard Schüßler

Contact:
Schöpfstraße 23a
6020 Innsbruck

Gerhard.Schuessler@i-med.ac.at
Phone: +43 512 504 27707
Fax: +43 512 504 6727708
<https://psychiatrie.tirol-kliniken.at/page.cfm?vpath=medizinische-p>

Research Branch (ÖSTAT Classification)

301402, 301905, 302045,
302046, 302065

Keywords

Bio-psycho-social aspects of diseases, doctor-patient-relationship, psychotherapy

Research Focus

- Psychoneuroimmunology: investigation of psychosomatic/psychoneuroimmunological complexity
- Patient reported outcomes
- Quality of life, health psychology, well-being, psychometric assessment, questionnaire development, positive psychology
- Transplant psychology: psychosocial evaluation, treatment protocols
- Cognitive Neuroscience: neuronal processing for cognitive processes e.g. language
- Psychotraumatology and Trauma Therapy
- Psychotherapy research concerning emotions, diagnosis, efficacy and delivery

General Facts

The **Psychoneuroimmunology Laboratory** run by a.o. Prof. DDr. Christian Schubert was founded in 1995. Currently, there is strong collaboration activity with Division of Biological Chemistry, Biocentre, Innsbruck Medical University, Innsbruck, Austria (a.o.

Prof. Dr. Dietmar Fuchs).

The Center for Advanced Psychology in Plastic and Transplant Surgery (CAPPTS) represents a psychological center of excellence that is dedicated to the psychosocial evaluation of different transplant candidates, particularly of living kidney donors and recipients as well as other candidates undergoing vascularized composite allotransplantation (VCA) or solid organ transplantation.

The research group **ICONE - Innsbruck Cognitive Neuroscience** cooperates locally and internationally. The facility "Lab for Cognitive Neurosciences Innsbruck" is fully equipped with electroencephalography (EEG), functional near-infrared spectroscopy (fNIRS), and behavioural measuring methods suitable for studies in infants, children, adults, and patients.

The working group "**Psychotraumatology and Trauma Therapy**" examines the effects of specific trauma-therapeutic treatment in patients with complex post-traumatic stress disorders (cPTSD) and in patients with dissociative disorders. In this project the group works together with European research groups.

A broad **training of medical students in doctor-patient-relationship and communication** is one major task. A psychotherapeutic inpatient and mainly outpatient clinic gives the opportunity for research in this

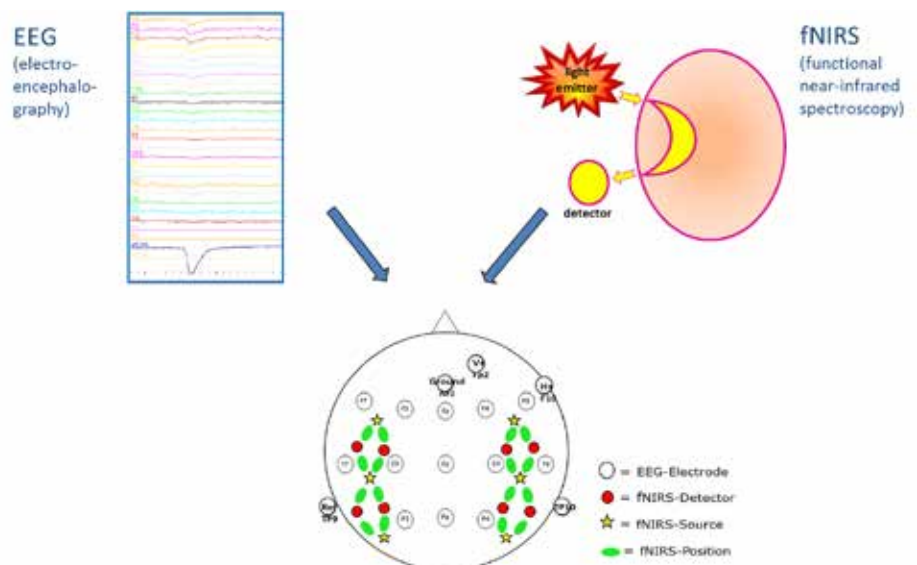

Fig. 1: Simultaneous assessment of electrophysiological and vascular signals by means of the electroencephalography and the functional near-infrared spectroscopy.

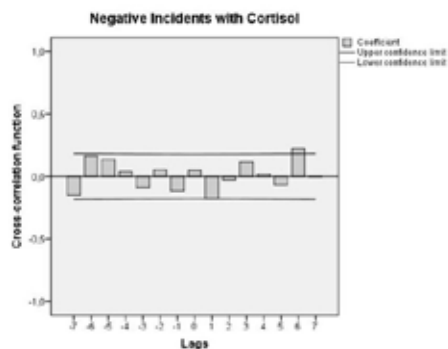

Fig. 2: Negative Incidents with Cortisol.

clinical field. In 2014 a highly competitive grant from the Austrian Science Foundation (P 27228-G22) was received to focus on the health and well-being of medical students and practitioners. In particular health professionals in the medical field are prone to burnout. This research project focuses on identifying key factors to promote health and well-being throughout the medical curricula. The unique approach is to investigate environmental (work- and organisational psychology) as well as personal factors (health psychology, positive psychology) together to determine pathways to health and well-being throughout the professional life.

Research

Psychoneuroimmunology

Christian Schubert

Stress system dynamics during “life as it is lived”: integrative single-case studies on healthy women and women with LE, breast cancer, depression et al.

Transplantation Psychology

Martin Kumnig

Psychological assessments are crucial for the evaluation and optimization of the suitability of transplant patients, considering solid organ or vascularized composite allotransplantation (VCA). Psychological assessment is mandatory for living kidney donation.

Lab for Cognitive Neurosciences

Sonja Rossi

The research group “ICONE – Innsbruck Cognitive Neuroscience” focuses primarily on neuronal processing mechanisms during first and second language acquisition in infancy and adulthood. Furthermore, the interaction between language and cognitive processes such as cognitive control, attention or memory is put under investigation. Neuronal markers are assessed by means of the electroencephalography (EEG) and

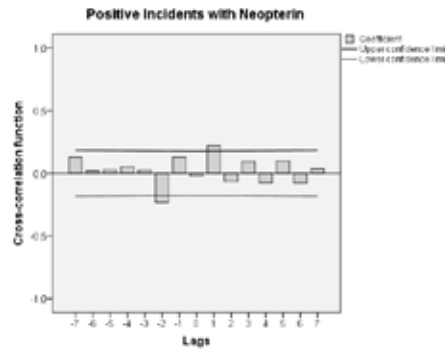

Fig. 3: Positive Incidents with Neopterin.

the near-infrared spectroscopy (fNIRS), both applicable also simultaneously.

Health Psychology

Stefan Höfer

Research focuses on three key areas: the first key area is the development of international patient reported outcome measures in different areas (i.e. heart disease) and different languages worldwide (i.e. Malay, Tagalog, Korean). The application of health psychological theories to enhance the quality of life and well-being of patients is the second key area. The third is the health and well-being of medical students and resident physicians. Prof. Höfer is the current conference president of the 15th annual meeting of the International Society for Quality-of-Life Studies, to be held on September 28-30, 2017.

Psychotraumatology and Trauma Therapy

Astrid Lampe

In addition to the main task of trauma therapy, the effects of training measures to sensitize medical professionals for domestic violence are reviewed and possible negative consequences of traumatic events are surveyed regarding the prevalence for illnesses. Within the project “The experience and the stress processing of executives in emergency organisations” two measure packages have been developed; on one hand a self-management tool for executives which helps the affected executives to efficiently adjust their stress load, on the other hand a guide for psychosocial experts for the professional support of stress-loaded executives. The annual meeting of the Society for Psychotraumatology (DeGPT) 2015 took place in Innsbruck. The focus was on the health consequences of severe stress in childhood, epigenetics, and brain development after traumatic stress in childhood.

Selected Publications

Cause-effect relations between 55 kD soluble TNF receptor concentrations and specific and unspecific symptoms in a patient with mild SLE disease activity: an exploratory time series analysis study.

Schubert, Christian, Haberkorn, Julia, Ocaña-Peinado, Francisco M., König, Paul, Sepp, Norbert, Schnapka-Köpf, Mirjam, Fuchs, Dietmar,
BMC RESEARCH NOTES: 2015; 8: S. 465

Standardizing psychosocial assessment for vascularized composite allotransplantation

Jowsey-Gregoire, Sheila, Kumnig, Martin,
CURRENT OPINION IN ORGAN TRANSPLANTATION: 2016; 21: S. 530-535

Functional and Psychosocial Outcomes of Hand Transplantation Compared with Prosthetic Fitting in Below-Elbow Amputees: A Multicenter Cohort Study

Salminger, Stefan, Sturma, Agnes, Roche, Aidan D., Hruby, Laura A., Paternostro-Sluga, Tatjana, Kumnig, Martin, Ninkovic, Marina, Pierer, Gerhard, Schneeberger, Stefan, Gabl, Markus, Chelmonski, Adam, Jablęcki, Jerzy, Aszmann, Oskar C.,
PLOS ONE: 2016; 11: S. e0162507

Key psychosocial challenges in vascularized composite allotransplantation

Kumnig, Martin, Jowsey-Gregoire, Sheila G.,
WORLD JOURNAL OF TRANSPLANTATION: 2016; 6: S. 91-102

The Chauvet 2014 Meeting Report: Psychiatric and Psychosocial Evaluation and Outcomes of Upper Extremity Grafted Patients

Jowsey-Gregoire, Sheila G., Kumnig, Martin, Morelon, Emmanuel, Moreno, Elisa, Petruzzo, Palmira, Seulin, Christian,
TRANSPLANTATION: 2016; 100: S. 1453-1459

International SF-36 reference values in patients with ischemic heart disease

Huber, Alexandra, Oldridge, Neil, Hofer, Stefan,
QUALITY OF LIFE RESEARCH: 2016; 25: S. 2787-2798

The dimensional structure of the MacNess Health Related Quality of Life questionnaire: A Mokken Scale Analysis

Friedrich, O., Sipoetz, J., Benzer, W., Kunschitz, E., Hofer, S.,
JOURNAL OF PSYCHOSOMATIC RESEARCH: 2015; 79: S. 43-48

Supporting cardiac patient physical activity: a brief health psychological intervention

Platter, Marion, Hofer, Markus, Hoelzl, Cornelia, Huber, Alexandra, Renn, Daniela, Webb, Dave, Hofer, Stefan,
WIENER KLINISCHE WOCHENSCHRIFT: 2016; 128: S. 175-181

Psychosocial aspects in cardiac rehabilitation: From theory to practice. A position paper from the Cardiac Rehabilitation Section of the European Association of Cardiovascular Prevention and Rehabilitation of the European Society of Cardiology

Pogosova, Nana, Saner, Hugo, Pedersen, Susanne S., Cupples, Margaret E., Mojee, Hannah, Hofer, Stefan, Doyle, Frank, Schmid, Jean-Paul, von Kaenel, Roland, Cardiovasc Prevention & Rehabil Eu,
EUROPEAN JOURNAL OF PREVENTIVE CARDIOLOGY: 2015; 22: S. 1290-1306

Health-related long-term effects of adverse childhood experiences - an update

Egle, Ulrich T., Franz, Matthias, Joraschky, Peter, Lampe, Astrid, Seiffge-Krenke, Inge, Cierpka, Manfred,
BUNDESGESUNDHEITSBLATT-GESUNDHEITSFORSCHUNG-GESUNDHEITSSCHUTZ: 2016; 59: S. 1247-1254

Psychosocial factors in reproductive medicine

Lampe, Astrid, Schuessler, Gerhard,
ZEITSCHRIFT FÜR PSYCHOSOMATISCHE MEDIZIN UND PSYCHOTHERAPIE: 2015; 61: S. 309-326

Selected Funding

Austrian Science Foundation 2014-2017, Stefan Höfer

Collaborations

Multiple international cooperations, s.a.

Child and Adolescent Psychiatry



Director:
Univ.-Prof.ⁱⁿ Dr.ⁱⁿ Kathrin Sevecke

Contact:
Anichstraße 35
6020 Innsbruck

Kathrin.Sevecke@tirol-kliniken.at
Phone: +43 512 504 23670
Fax: +43 512 504 23650
<https://psychiatrie.tirol-kliniken.at/page.cfm?vpath=kinder-und-jugendpsychiatrie>

Research Branch (ÖSTAT Classification)

302036, 501005, 501009, 501010

Keywords

Child and adolescent psychiatry, child and adolescent psychology, clinical psychiatry, psychopathology, psychotherapy, personality disorders, eating disorders, attachment research, internet addiction, cyber-mobbing

Research Focus

Assessment and Course of Personality Disorders in Adolescence: The diagnosis of personality disorders (PD) in adolescence has long been controversially discussed in the research literature. Major concerns include the validity and stability of diagnosing PD, the heterogeneity of the psychopathological profile and stigmatisation in that age group. Even though studies on temperament and personality evidence that the main ingredients of adult PD are present during puberty, only very little is known about the course of these disorders in adolescents. Therefore, the purpose of this study to examine underlying dimensions (e.g. attachment patterns, emotion regulation, integration level of mental structure) mediating the course and outcome of PD in adolescents. Furthermore, we are interested in examining possible links between attachment representations, symptom severity, comorbid disorders, course and outcome in adolescent patients with PD.

Attachment and Eating Disorders in Adolescence: The emerging body of attachment research in patients with eating disorders (ED) provides us with a promising insight into the interplay between environmental, social and individual factors and

how they contribute to the development of this complex and painful condition. The aim of our research is to assess attachment representations in adolescent patients with Anorexia Nervosa or Bulimia Nervosa. We will analyse attachment themes concerning parent-child relationships and experiences of separation, abuse and loss in the attachment narratives of our adolescent ED patients. Additionally, we are interested in the links between attachment representations, symptom severity, comorbid disorders and personality pathology. One of the most challenging directions taken by attachment researchers focuses on the influence of attachment representations on the course and outcome of mental disorders. To date, there is no study investigating that influence in adolescent patients with ED. Thus, we want to examine the influence of attachment representations on the outcome and also analyse the extent to which attachment can change after treatment for the first time.

General Facts

This is a new research unit with a special focus on personality pathology and attachment research in child and adolescent psychiatry.

Collaborations inside the MUI:

- Neuropsychimmunology in adolescent patients with eating disorders (Univ.- Prof. Dr. Dietmar Fuchs, Section for biological chemistry, Biocenter Innsbruck)
- Neural correlates and personality pathology in adolescents with eating disorders (Univ.-Prof. Dr. Elke Gizewski, Department of Radiology, Medical University of Innsbruck)



*Dr. Astrid Bock,
Senior Scientist (Postdoc)*



*Dr. Manuela Gander,
Senior Scientist (Postdoc)*



*Dr. Martin Fuchs,
Specialist for Child and
Adolescent Psychiatry*

Research

Assessment and Course of Personality Disorders in Adolescence

*Prof. Dr. Kathrin Sevecke,
Dr. Manuela Gander, Dr. Astrid Bock*

The purpose of this study is to examine underlying dimensions (e.g. attachment patterns, emotion regulation, integration level of mental structure) mediating the course and outcome of PD in adolescents. Furthermore, we are interested in examining possible links between attachment representations, symptom severity, comorbid disorders, course and outcome in adolescent patients with PD.

Attachment and Eating Disorders in Adolescence

Prof. Dr. Kathrin Sevecke, Dr. Manuela Gander, Prof. Dr. Anna Buchheim

The aim of our research is to assess attachment representations in adolescent patients with Anorexia Nervosa and Bulimia Nervosa and analyse their influence on the outcome.

Neuropsychimmunology in Adolescent Patients with Eating Disorders

*Prof. Dr. Dietmar Fuchs,
Prof. Dr. Kathrin Sevecke*

To examine relevant neurotransmitters in plasma samples of patients with Anorexia Nervosa.

Neural Correlates and Personality Pathology in Adolescents with Eating Disorders

*Prof. Dr. Elke Gizewski,
Prof. Dr. Kathrin Sevecke*

To investigate neural correlates of adolescents with eating disorders while watching visual food cues in an fMRI environment.

Emotional and Structural Indicators of Psychopathological Development in Adolescence

Dr. Astrid Bock

The aim of this study is to examine factors like affect regulation and emotion recognition that might contribute to the early onset of psychopathology in adolescence.

Digital Media

Prof. Dr. Kathrin Sevecke, Dr. Martin Fuchs

This research study investigates the use, the potential misuse and comorbidities of excessive use of digital media in children and adolescents.

Assessing Trauma in Children and Adolescents

*Univ.-Prof. Dr. Barbara Juen,
Prof. Dr. Kathrin Sevecke*

This study aims to improve the assessment of trauma and analyse consequences of traumatic experiences in children and adolescents.

Self-Injurious Behaviours in Adolescent Psychiatric In- and Outpatients

*Univ.- Prof. Dr. Kathrin Sevecke,
Dr. Martin Fuchs*

This research topic focuses on the prevalence of self-injurious behaviours (SIB) in our adolescent patients and analyses the most common forms, the frequency, duration and severity of these behaviours within the different psychiatric disorders.

Selected Publications

Emotional dysregulation and trauma predicting psychopathy dimensions in female and male juvenile offenders, Child and Adolescent Psychiatry and Mental Health

Sevecke Kathrin, Franke, Sebastian, Kossen, David, Krischer, Maya,
CHILD AND ADOLESCENT PSYCHIATRY AND MENTAL HEALTH: 2016; 10: S. 43

Child and adolescent psychiatry patients coming of age: a retrospective longitudinal study of inpatient treatment in Tyrol

Fuchs, Martin, Kemmler, Georg, Steiner, Hans, Marksteiner, Josef, Haring, Christian, Miller, Carl, Hausmann, Armand, Sevecke Kathrin
BMC PSYCHIATRY: 2016; 16: S. 225

Nutzungsmuster von Internet und Computerspielen: Ergebnisse einer Beobachtungsstudie an Tiroler Jugendlichen

Riedl, David, Stöckl, Andrea.; Nußbaumer, Charlotte, Rumpold, Gerhard, Sevecke, Kathrin, Fuchs, Martin
NEUROPSYCHIATRIE: 2016; 30: S. 181-190

Eating disorders in adolescence: Attachment issues from a developmental perspective

Gander, Manuela, Sevecke, Kathrin, Buchheim, Anna
FRONTIERS IN PSYCHOLOGY: 2015; 6: S. 1136

Collaborations

- Univ.-Prof. Dr. Anna Buchheim, Institute of Psychology at the University of Innsbruck, Austria
- Univ.-Prof. Dr. Barbara Juen, Institute of Psychology at the University of Innsbruck, Austria
- Univ.-Prof. Dr. Svenja Taubner, Institute for Psychosocial Prevention at the Universitätsklinikum Heidelberg, Germany
- Dr. Florian Juen, KBO Child Center Munich, Germany
- Prof. Dr. med. Dipl. Psych. Klaus Schmeck, KJPK Basel, Switzerland
- PD Dr.Maya Krischer, Department of Child and Adolescent Psychiatry, Psychosomatics and Psychotherapy, Cologne, Germany

Neurology



Director:
o. Univ.-Prof. Dr. Werner Poewe

Contact:
Anichstraße 35
6020 Innsbruck

werner.poewe@i-med.ac.at
Phone: +43 512 504 23850
Fax: +43 512 504 23852
www.i-med.ac.at/neurologie

Research Branch (ÖSTAT Classification)

301402, 302052, 301401,
302073, 302043

Keywords

Multiple sclerosis, neuroimmunology, neurointensive care medicine, stroke, neurovascular research, movement disorders, Parkinson's Disease, chorea, multiple system atrophy, sleep, polysomnography, daytime sleepiness, narcolepsy, restless legs syndrome, neurobiology, computational neuroscience

Research Focus

The clinical Department of Neurology at the Medical University of Innsbruck has an internationally-established research focus in the fields of epidemiology and pathophysiology of ischemic stroke, neurocritical care (including infectious diseases of the nervous system), Parkinson's Disease, MSA and degenerative movement disorders. In addition, the department is the only academic institution in Austria with an internationally recognised and certified sleep laboratory with a focus on research into the field of sleep-related movement disorders, as well

as MS and neuroimmunology and cognitive neurology. The Division of Neurobiology is focused on animal modelling of neurodegeneration with an emphasis on multiple system atrophy. A recently-established professorship for computational neuroscience is concerned with establishing novel image analysis algorithms for MRI datasets.

General Facts

The Department of Neurology at Innsbruck Medical University has a total of 114 in-patient beds including a stroke unit (8 beds), a neurocritical care unit (10 fully-ventilated beds, 6 post-immediate care beds), an epilepsy monitoring unit (4 beds) and a dedicated sleep laboratory (6 beds). The department acts as a referral centre for the entire spectrum of neurological diseases encompassing the entire area of the state of Tyrol and neighbouring areas. Furthermore, the department receives referrals on an Austria-wide scale when second opinions and specialised diagnostic and therapeutic procedures are required. The large number of patients received by the department each year (more than 6,000 in-patient admissions per year, close to 40,000 out-patient contacts per year) results in a significant clinical routine workload. Key collaborations in the field of clinical routine include joint programs with the Department of Neurosurgery, in particular vascular surgery, neurooncology, epilepsy surgery and deep brain stimulation for movement disorders. Equally close collaborations exist with the Departments of Neuroradiology and Vascular Surgery and Cardiology in the field of stroke medicine. Research collaborations in the field of neuroimaging are centred upon the Department of Neuroradiology and Nuclear Medicine. Dedicated research infrastructures within the clinical department include the Division of Neurobiology (animal modelling of neurodegeneration), the neurological research laboratory (focus on biomarker research and neuroimmunology), as well as the recently established computational neuroscience unit for the development of novel image analysis algorithms.

Prizes

1. Werner Poewe: Wissenschaftspreis Verband der Professorinnen und Professoren der Innsbrucker Universitäten (UPVI) 2015
2. Stefan Kiechl: Tiroler Landespreis für Wissenschaft 2016, Research Excellence Award of the European Stroke Organisation 2016

3. Peter Willeit: Förderungspreis des Landes Tirol für Wissenschaft 2016
4. Philipp Mahlknecht: Preis der Ärztekammer für Tirol 2015
5. Gregor Wenning: Dr. Johannes Tuba Preis 2015 der Ärztekammer für Tirol

Research

Research Group Stroke

Leaders: ao. Univ.-Prof. Johann Willeit, ao. Univ.-Prof. Stefan Kiechl, Assoz. Prof. PD Michael Knoflach
Research priorities of the neurovascular research group are acute and post-acute stroke care, atherosclerosis and vascular biology, as well as cardiovascular ageing. High-quality epidemiological research is based on the internationally-respected Bruneck Study and the large international Proof-ATHERO consortium (PI Peter Willeit). Johann Willeit and Stefan Kiechl head the 'Research Center of Excellence in Vascular Ageing - Tyrol' which has its headquarters in Innsbruck (4.3 Mio €), the Tyrol Stroke Pathway and the largest RCT on post-stroke disease management (Stroke Card). Risk predictors for stroke recurrence in patients with cervical artery dissections are currently evaluated in a project funded by the Anniversary Fund of the Austrian National Bank. (PI: Michael Knoflach).

Research Group Multiple Sclerosis and Neuroimmunology

Leaders: ao. Univ.-Prof. Thomas Berger, ao. Univ.-Prof. Florian Deisenhammer, ao. Univ.-Prof. Markus Reindl
Embedded in long-lasting and excellent research collaborations the main research topics are related to pathomechanisms, clinical and therapeutic aspects of autoimmune CNS and PNS disorders: multiple sclerosis (MS), antibody-associated neurological disease (neuromyelitis optica [NMO], acute disseminated encephalomyelitis or NMDAR-encephalitis) and immune neuropathies. Thus, scientific foci are the role of human autoantibodies directed against different CNS tissue antigens (mainly MOG, AQP4 and NMDA-R) and neutralising antibodies in the monitoring of various MS treatments. These research activities are committed to complement and translate to our neurological laboratory diagnostics. In addition, extensive databases for MS and NMO have been established, which are of paramount importance for past and current research activities, both national and international.

Research Group Neurocritical Care and Infectious Diseases of the Nervous System

Leaders: Univ.-Prof. Erich Schmutzhard, PD Bettina Pfausler, Assoz. Prof. PD Ronny Beer, PD Raimund Helbok

This study group focuses both in clinical and translational research. Invasive multimodal neuromonitoring, covering structural (imaging), metabolic (microdialysis, PBtO₂, CBF), functional monitoring (electrocorticography – COSBID) and the clinical aspects of neurocritical care (blood pressure and glucose management, nosocomial infections, ventilator associated pneumonia, monitoring and management of post-intensive care dysphagia, etc.) are major foci in the department's research. Furthermore, the influence of enteral and/or parenteral nutrition towards brain metabolism is another research focus. The research group participates in a number of international multicentre trials, in particular traumatic brain injury, nutrition of neurocritical care patients, aneurysmatic spontaneous subarachnoid haemorrhage, intracerebral haemorrhage, refractory convulsive status epilepticus, etc. Major achievements result from this tight collaboration with regional, European and international neurocritical care.

Research Group Movement Disorders

Leaders: o. Univ.-Prof. Werner Poewe, ao. Univ.-Prof. Klaus Seppi, Univ.-Prof. Christoph Scherfler, PD Sylvia Bösch, Univ.-Prof. Gregor K. Wenning

Movement disorders groups at the Department of Neurology and their partners at MUI have established an internationally recognised clinical research focus on degenerative movement disorders including Parkinson's disease (PD) and related syndromes. Major contributions have been in the field of clinical trials in PD, rating scale development for PD and multiple system atrophy (MSA), natural history and imaging studies in parkinsonian syndromes and other movement disorders, with key papers in major journals like the *Annals of Neurology*, *JAMA Neurology*, *Neurology*, *Brain*, *Lancet Neurology*, *NEJM* or *Nature communications*. It is involved in multiple international research consortia and networks and between 2015 and 2016 authored and co-authored a total of 82 papers in peer-reviewed journals. Recent clinical research projects have focussed on the epidemiology, genetics and natural history of PD and other movement disorders including dystonia, MSA, Huntington's disease (HD) and ataxias, on the validation of imaging and biomarker studies for PD, MSA, ataxias and related disorders as

well as on clinical trials in PD and related movement disorders. Current aims are to validate biomarkers on early diagnosis and progression of PD, MSA and other movement disorders including HD and ataxias as well as to introduce clinical trials of novel therapies for these disorders, including an EU-funded conservative iron chelation therapy as a disease-modifying strategy in PD and a deep brain stimulation (globus pallidus) therapy as a symptomatic treatment strategy in HD.

Major achievements: Completion of an immunisation trial against alpha-synuclein, identification of risk factors and prodromal markers for the development of PD, natural history study of different ataxias.

Future goals: better characterisation of premotor PD, clinical trials on novel therapeutics for PD, MSA and other movement disorders.

Research Group Sleep Medicine

Leader: ao. Univ.-Prof. Birgit Högl

The Sleep Laboratory and Sleep Disorders Research Group at the Department of Neurology serves a dual purpose of research and clinics. From a research perspective, the main focus is on restless legs syndrome and REM sleep behaviour disorder, and other motor disorders of sleep. The Sleep Research Group publishes more than 20 papers per year and has funding from FWF, ÖNB, Michael J. Fox Foundation and the pharmacological industry.

Clinically, the sleep lab is a high-tech modern facility with an advanced sleep lab, a large outpatient clinic and the possibility to perform state of the art video polysomnography and several additional relevant investigations, including ambulatory cardiorespiratory polygraphy, pupillography, different types of actigraphy and measurements of circadian functions.

The group has high international recognition and cooperation with various research groups at Harvard University, Stanford University, Tokyo University, Barcelona University and Technical University of Munich, to name but a few.

The sleep disorders unit (sleep lab and Sleep Research Group) at Innsbruck Medical University, Department of Neurology is headed by Birgit Högl, with Elisabeth Brandauer and Melanie Bergmann in her team.

Current Research Group members are Ambra Stefani (PhD student) and Evi Holzknecht (PhD student), the Head Technician is Heinz Hackner.

Division of Neurobiology

Leaders: Univ.-Prof. Gregor K. Wenning, Assoz. Prof. PD Nadia Stefanova

The research programme at the Division of Neurobiology focuses on multiple system atrophy (MSA), a neurodegenerative disorder associated with autonomic failure, ataxia and parkinsonism. Over the last decade our research group has made important contributions regarding clinical presentation, diagnostic tools and pathogenesis of MSA. We are especially interested in α -synuclein mediated oligodendroglial pathology that includes protein misfolding and aggregation as well as cell-to-cell propagation. We identified fundamental interactions between MSA pathology and mitochondrial or proteolytic stress. The latter contribute to the specific neuronal vulnerability in MSA and represent powerful interventional targets. We were the first to demonstrate that the toll-like receptor 4 (TLR4) promotes α -synuclein clearance by microglia.

More recently our work also involved pre-clinical screening of candidate neuroprotective and neuroregenerative strategies that are currently being evaluated for safety and efficacy in controlled clinical trials

Computational Neuroscience

Leader: Univ.-Prof. Christoph Scherfler

The research unit for Computational Neuroscience was established within the Department of Neurology in October 2014 to accommodate and support existing research groups in the field of MRI and PET image analysis. The unit is tightly intertwined with the Department of Neuroradiology and has broad access to the MRI core facility, equipped with a dedicated 3 Tesla research tomograph. Members of the laboratory are developing and exploring mathematical models of structural and functional image analysis for its value to be translated into the routine neurological and radiological work-up of patients with CNS disorders. Due to long-lasting expertise in the field of movement disorders, the main focus was set to neurodegenerative parkinsonian disorders and was recently extended to neurodegenerative dementias, sleep disorders and intracranial haemorrhages. (contact: Prof. Christoph Scherfler Research Unit for Computational Neuroscience, Department of Neurology, email: christoph.scherfler@i-med.ac.at).

Research Group Cognitive Neurology and Neuropsychology

Leaders: ao. Univ.-Prof. Thomas Benke, ao. Univ.-Prof. Margarete Delazer

The research group focuses on the neu-

ropsychological consequences of neurological diseases as well as on the elucidation of neurological mechanisms supporting cognition. Main topics of the group include decision processes in neurological disease and healthy ageing, the neurological implementation of numerical processing, rehabilitation and learning. An extensive database for Alzheimer's disease has been established in collaboration with other national centres, which is of major importance in current and future research. Research methods include neuro-psychological experimental methods, eye-tracking analysis and various methods of brain imaging together with the research group computational neuroscience. Further issues are related to the early diagnosis of Alzheimer's disease, and the frontotemporal and vascular dementia complex.

Selected Publications

Research Group Stroke

Thrombolysis and clinical outcome in patients with stroke after implementation of the Tyrol Stroke Pathway: a retrospective observational study

Willeit, Johann, Geley, Theresa, Schoech, Johannes, Rinner, Heinrich, Tuer, Andreas, Kreuzer, Hans, Thiemann, Norbert, Knoflach, Michael, Toell, Thomas, Pechlauer, Raimund, Willeit, Karin, Klingler, Natalie, Praxmarer, Silvia, Baubin, Michael, Beck, Gertrud, Bereik, Klaus, Spengg, Christian, Engelhardt, Klaus, Erlacher, Thomas, Fluckinger, Thomas, Grandner, Wilhelm, Grossmann, Josef, Kathrein, Hermann, Kaiser, Norbert, Matosevic, Benjamin, Matzak, Heinrich, Mayr, Markus, Perfler, Robert, Poewe, Werner, Rauter, Alexandra, Schoenherr, Gudrun, Schoenherr, Hans-Robert, Schinnerl, Adolf, Spiss, Heinrich, Thurner, Theresa, Vergeiner, Gernot, Werner, Philipp, Woell, Ewald, Willeit, Peter, Kiechl, Stefan, NEUROLOGY: 2015; 14: S. 48-56

Predictive value of ABCD2 and ABCD3-I scores in TIA and minor stroke in the stroke unit setting

Knoflach, Michael, Lang, Wilfried, Seyfang, Leonhard, Fertl, Elisabeth, Oberndorfer, Stefan, Daniel, Gerhard, Seifert-Held, Thomas, Brainin, Michael, Krebs, Stefan, Matosevic, Benjamin, Toll, Thomas, Kiechl, Stefan, Willeit, Johann, Ferrari, Julia, Austrian Stroke Unit Collaborators, NEUROLOGY: 2016; 87: S. 861-869

Cardioprotection and lifespan extension by the natural polyamine spermidine

Eisenberg, Tobias, Abdellatif, Mahmoud, Schroeder, Sabrina, Primessnig, Uwe, Stekovic, Slaven, Pendl, Tobias, Harger, Alexandra, Schipke, Julia, Zimmermann, Andreas, Schmidt, Albrecht, Tong, Mingming, Ruckenstein, Christoph, Dammbroeck, Christopher, Gross, Angelina S., Herbst, Viktoria, Magnes, Christoph, Trausinger, Gert, Narath, Sophie, Meinitzer, Andreas, Hu, Zehan, Kirsch, Alexander, Eller, Kathrin, Carmona-Gutierrez, Didac, Buettner, Sabrina, Pietrocola, Federico, Knittelfelder, Oskar, Schrepfer, Emilie, Rockenfeller, Patrick, Simonini, Corinna, Rahn, Alexandros, Horsch, Marion, Moreth, Kristin, Beckers, Johannes, Fuchs, Helmut, Gailus-Durner, Valerie, Neff, Frauke, Janik, Dirk, Rathkolb, Birgit, Rozman, Jan, de Angelis, Martin Hrabec, Moustafa, Tarek, Haemmerle, Guenter, Mayr, Manuel, Willeit, Peter, von Frieling-Salewsky, Marion, Pieske, Burkert, Scorrano, Luca, Pieber, Thomas, Pechlauer, Raimund, Willeit, Johann, Sigrist, Stephan J., Linke, Wolfgang A., Muehlfeld, Christian, Sadoshima, Junichi, Dengjel, Joern, Kiechl, Stefan, Kroemer, Guido, Sedej, Simon, Madeo, Frank, NATURE MEDICINE: 2016; 22: S. 1428-+

Research Group Multiple Sclerosis and Neuroimmunology

Long Term Clinical Prognostic Factors in Relapsing-Remitting Multiple Sclerosis: Insights from a 10-Year Observational Study

Bsteh, Gabriel, Ehling, Rainer, Lutterotti, Andreas, Hegen, Harald, Di Pauli, Franziska, Auer, Michael, Deisenhammer, Florian, Reindl, Markus, Berger, Thomas, PLOS ONE: 2016; 11: S. e0158978

A clinical approach to diagnosis of autoimmune encephalitis
Graus, Francesc, Titulaer, Maarten J., Balu, Ramani, Benseler, Susanne, Bien, Christian G., Cellucci, Tania, Cortese, Irene, Dale, Russell C., Gelfand, Jeffrey M., Geschwind, Michael, Glaser, Carol A., Honnorat, Jerome, Hoeflberger, Romana, Iizuka, Takahiro, Irani, Sarosh R., Lancaster, Eric, Leypoldt, Frank, Pruess, Harald, Rae-Grant, Alexander, Reindl, Markus, Rosenfeld, Myra R., Rostasy, Kevin, Saiz, Albert, Venkatesan, Arun, Vincent, Angela, Wandinger, Klaus-Peter, Waters, Patrick, Dalmau, Josep, LANCET NEUROLOGY: 2016; 15: S. 391-404

Multicentre comparison of a diagnostic assay: aquaporin-4 antibodies in neuromyelitis optica

Waters, Patrick, Reindl, Markus, Saiz, Albert, Schanda, Kathrin, Tuller, Friederike, Kral, Vlastimil, Nytrova, Petra, Sobek, Ondrej, Nielsen, Helle Hvilsted, Barington, Torben, Lillevang, Soren T., Illes, Zsolt, Rentzsch, Kristin, Berthele, Achim, Berki, Timea, Granieri, Letizia, Bertolotto, Antonio, Giometto, Bruno, Zuliani, Luigi, Hamann, Dorte, van Pelt, E. Danielle, Hintzen, Rogier, Hoeflberger, Romana, Costa, Carme, Comabella, Manuel, Montalban, Xavier, Tintore, Mar, Siva, Aksel, Alintias, Ayse, Deniz, Gunnur, Woodhall, Mark, Palace, Jacqueline, Paul, Friedemann, Hartung, Hans-Peter, Aktas, Orhan, Jarius, Sven, Wildemann, Brigitte, Vedeler, Christian, Ruiz, Anne, Leite, M. Isabel, Trillenberger, Peter, Hobbs, Monika, Saschenbrecker, Sandra, Vincent, Angela, Marignier, Romain, JOURNAL OF NEUROLOGY NEUROSURGERY AND PSYCHIATRY: 2016; 87: S. 1005-1015

Research Group Neurocritical Care and Infectious Diseases of the Nervous System

Results of the ICTuS 2 Trial (Intravascular Cooling in the Treatment of Stroke 2)

Lyden, P., Hemmen, T., Grotta, J., Rapp, K., Ernstrom, K., Rzesiewicz, T., Parker, S., Concha, M., Hussain, S., Agarwal, S., Meyer, B., Jurf, J., Altafullah, I., Raman, R., Hess, M.J., Mullin, A., Jane, Hess, M., Muranevici, G., Piantadosi, B., Jimenez-Maggiore, G., So, J.S., Jain, S., Diring, M., Derdeyn, C., Stern, B., Hamilton, S., Dietrich, D., Becker, K., Yenari, M., Dirnagl, U., Wijman, C., Chamorro, A., Janis, S., Moy, C., Lin, F., Song, S., Schlick, K., Khanolkar, P., Edwards, N.J., Roldan, A., Wilson, J., Little, A., Lewis, P., Neil, W., Bruce, N., Guzik, A., Sohdi, A., Herial, N., Ovbiagele, B., Meyer, D., Modir, R., Chavez, R., Velazquez, A., Mayer, S., Claassen, J., Falco, C., Tafreshi, G., Neil, W., Bruce, N., Guzik, A., Modir, R., Kelly, N., Chavez, R., Ovbiagele, B., Shell, E., Dugan, G., Kim, E., Tanner, A., Michel, P., Eskandari, A., Oddo, M., Suys, T., Remillard, S., Cordier, M., Brown, R., Jasak, M., McCullough, L., Brautigam, R., Alexandrov, A., Sisson, A., Albright, K., Broessner, G., Schmutzhard, E., Escioglou, E., Jones, W., Poisson, S., Simpson, J., Shah, Q., Jonczak, K., Bussinger, P., Lewandowski, C., Berry, S., Lundell, A., Miller, J.B., Cruz-Flores, S., Holzer, E., Torretta, S., Brown, D., Heim, L., Smith, C., Kelley, C., Greer, D., Marcolini, E.G., Gilmore, E.J., Rutledge, N., McBea, D., Khanna, A., Warren, S., Wilsom, C., Shushrutha Hedna, V., Rosado, C., Kizza, R., O'Phelan, K., Escobar, A., Merenda, A., Perez Barcena, J., Malik, A., STROKE: 2016; 47: S. 2888-2895

Clinical findings and management of patients with meningitis with an emphasis on Haemophilus influenzae meningitis in rural Tanzania

Storz, Corinna, Schutz, Cornelia, Tluway, Anthony, Matuja, William, Schmutzhard, Erich, Windler, Andrea S., JOURNAL OF THE NEUROLOGICAL SCIENCES: 2016; 366: S. 52-58

Prognostic Significance of Hyponatremia in Acute Intracerebral Hemorrhage: Pooled Analysis of the Intensive Blood Pressure Reduction in Acute Cerebral Hemorrhage Trial Studies

Carcel, C., Sato S., Zheng D., Heeley E., Arima H., Yang J., Wu G., Chen G., Zhang S., Delcourt C., Lavados P., Robinson T., Lindley R.I., Wang X., Chalmers J., Anderson CS.; Intensive Blood Pressure Reduction in Acute Cerebral Hemorrhage Trial 2 Investigators., CRITICAL CARE MEDICINE: 2016; 44: S. 1388-1394

Research Group Movement Disorders

Loss of Dorsolateral Nigral Hyperintensity on 3.0 Tesla Susceptibility-Weighted Imaging in Idiopathic Rapid Eye Movement Sleep Behavior Disorder

De Marzi, Roberto, Seppi, Klaus, Hoegl, Birgit, Mueller, Christoph, Scherfler, Christoph, Stefani, Ambra, Iranzo, Alex, Tolosa, Eduardo, Santamaria, Joan, Gizewski, Elke, Schocke, Michael, Skalla, Elisabeth, Kremser, Christian, Poewe, Werner, ANNALS OF NEUROLOGY: 2016; 79: S. 1026-1030

Olfactory dysfunction predicts early transition to a Lewy body disease in idiopathic RBD

Mahlknecht, Philipp, Iranzo, Alex, Hoegl, Birgit, Frauscher, Birgit, Mueller, Christoph, Santamaria, Joan, Tolosa, Eduardo, Serradell, Monica, Mitterling, Thomas, Gschliesser, Viola, Goebel, Georg, Brugger, Florian, Scherfler, Christoph, Poewe, Werner, Seppi,

Klaus, SINBAR Sleep Innsbruck Barcelona, NEUROLOGY: 2015; 84: S. 654-658

Biological and clinical characteristics of the European Friedreich's Ataxia Consortium for Translational Studies (EFACTS) cohort: a cross-sectional analysis of baseline data

Reetz, Kathrin, Dogan, Imis, Costa, Ana S., Dafotakis, Manuel, Fedosov, Kathrin, Giunti, Paola, Parkinson, Michael H., Sweeney, Mary G., Mariotti, Caterina, Panzeri, Marta, Nanetti, Lorenzo, Arpa, Javier, Sanz-Gallego, Irene, Durr, Alexandra, Charles, Perrine, Boesch, Sylvia, Nachbauer, Wolfgang, Klopstock, Thomas, Karin, Ivan, Depondt, Chantal, Hagen, Jennifer Muller Vom, Schols, Ludger, Giordano, Iliaria A., Klockgether, Thomas, Burk, Katrin, Pandolfo, Massimo, Schulz, Joeg B., LANCET NEUROLOGY: 2015; 14: S. 174-182

Efficacy of rasagiline in patients with the parkinsonian variant of multiple system atrophy: a randomised, placebo-controlled trial

Poewe, Werner, Seppi, Klaus, Fitzer-Attas, Cheryl J., Wenning, Gregor K., Gilman, Sid, Low, Phillip A., Gladi, Nir, Barone, Paolo, Sampaio, Cristina, Eyal, Eli, Rascol, Olivier, Rasagiline-for-MSA Investigators, LANCET NEUROLOGY: 2015; 14: S. 145-152

Substantia nigra hyperechogenicity and Parkinson's disease risk in patients with essential tremor

Sprenger, Fabienne S., Wurster, Isabel, Seppi, Klaus, Stockner, Heike, Scherfler, Christoph, Sojer, Martin, Schmidauer, Christof, Berg, Daniela, Poewe, Werner, MOVEMENT DISORDERS: 2016; 31: S. 579-583

Research Group Sleep Medicine

IgLON5 autoimmunity and abnormal behaviours during sleep

Hoegl, Birgit, Heidebreder, Anna, Santamaria, Joan, Graus, Francesc, Poewe, Werner, LANCET: 2015; 385: S. 1590-1590

Natural course of restless legs syndrome/Willis-Ekbom disease: long-term observation of a large clinical cohort

Mitterling, Thomas, Heidebreder, Anna, Stefani, Ambra, Fritz, Josef, Ulmer, Hanno, Poewe, Werner, Hoegl, Birgit, SLEEP MEDICINE: 2015; 16: S. 1252-1258

Risk Factors for Neurodegeneration in Idiopathic Rapid Eye Movement Sleep Behavior Disorder: A Multicenter Study

Postuma, Ronald B., Iranzo, Alex, Hogl, Birgit, Arnulf, Isabelle, Ferini-Strambi, Luigi, Manni, Raffaele, Miyamoto, Tomoyuki, Oertel, Wolfgang, Dauvilliers, Yves, Ju, Yo-Ei, Puligheddu, Monica, Sonka, Karel, Pelletier, Amelie, Santamaria, Joan, Frauscher, Birgit, Leu-Semenescu, Smaranda, Zucconi, Marco, Terzaghi, Michele, Miyamoto, Masayuki, Unger, Marcus M., Carlander, Bertrand, Fantini, Maria-Livia, Montplaisir, Jacques Y., ANNALS OF NEUROLOGY: 2015; 77: S. 830-839

Dreaming furiously? A sleep laboratory study on the dream content of people with Parkinson's disease and with or without rapid eye movement sleep behavior disorder

Valli, Katja, Frauscher, Birgit, Peltomaa, Taina, Gschliesser, Viola, Revonsuo, Antti, Hoegl, Birgit, SLEEP MEDICINE: 2015; 16: S. 419-427

Division of Neurobiology

Multiple-System Atrophy

Fanciulli, Alessandra, Wenning, Gregor K., NEW ENGLAND JOURNAL OF MEDICINE: 2015; 372: S. 249-263

Computational Neuroscience

Diagnostic potential of automated subcortical volume segmentation in atypical parkinsonism

Scherfler, Christoph, Goebel, Georg, Mueller, Christoph, Nocker, Michael, Wenning, Gregor K., Schocke, Michael, Poewe, Werner, Seppi, Klaus, NEUROLOGY: 2016; 86: S. 1242-1249

Longitudinal profile of iron accumulation in good-grade subarachnoid hemorrhage

Scherfler, Christoph, Schiefelker, Alois Josef, Delazer, Margarete, Beer, Ronny, Bodner, Thomas, Spinka, Georg, Kofler, Mario, Pfausler, Bettina, Kremser, Christian, Schocke, Michael, Benke, Thomas, Gizewski, Elke R., Schmutzhard, Erich, Helbok, Raimund, ANNALS OF CLINICAL AND TRANSLATIONAL NEUROLOGY: 2016; 3: S. 781-790

1.5 Versus 3 Tesla Magnetic Resonance Planimetry in Neurodegenerative Parkinsonism

Mangesius, Stephanie, Krismer, Florian, Gizewski, Elke R., Mueller, Christoph, Hussl, Anna, Schocke, Michael, Scherfler, Christoph,

Poewe, Werner, Seppi, Klaus,
MOVEMENT DISORDERS: 2016; 31: S. 1925-1927

Research Group Cognitive Neurology and Neuropsychology

Oxygen desaturation during night sleep affects decision-making in patients with obstructive sleep apnea

Delazer, Margarete, Zamarian, Laura, Fauscher, Birgit, Mitterling, Thomas, Stefani, Ambra, Heidebreder, Anna, Hoegl, Birgit,
JOURNAL OF SLEEP RESEARCH: 2016; 25: S. 395-403

Impaired Information Sampling in Mild Dementia of Alzheimer's Type but Not in Healthy Aging

Zamarian, Laura, Benke, Thomas, Brand, Matthias, Djamshidian, Atbin, Delazer, Margarete,
NEUROPSYCHOLOGY: 2015; 29: S. 353-367

Quantifying synchrony patterns in the EEG of Alzheimer's patients with linear and non-linear connectivity markers

Waser, Markus, Garn, Heinrich, Schmidt, Reinhold, Benke, Thomas, Dal-Bianco, Peter, Ransmayr, Gerhard, Schmidt, Helena, Seiler, Stephan, Sanin, Guenter, Mayer, Florian, Caravias, Georg, Grossegger, Dieter, Fruehwirt, Wolfgang, Deistler, Manfred,
JOURNAL OF NEURAL TRANSMISSION: 2016; 123: S. 297-316

Selected Funding

Research Group Stroke

In 2015 and 2016 funding was derived from the FWF (J 3679 Schrödinger-Program: Role of miR-122 in Cardiometabolic Disease), Standortagentur Tyrol (Translational Research Project Tyrol Score, 340 K€), the Reformpool (Tyrol Stroke Pathway, 200 K€) and the FFG (VASCage, 4300 K€). FFG recommended to submit a revised K1 Application VASCage-C in 2017 (19 Mio €). Funding of 800 K€ was obtained to conduct the post-Stroke Disease Management Project Stroke Card. The neurovascular research group participates in large international research and meta-analysis consortia (steering/writing committee: FSC, ERFC, LSC, NPSC, IMT-PROG, GBD, various GWA studies) and heads its own consortium Proof-ATHERO.

Research Group Multiple Sclerosis and Neuroimmunology

- 2016: Österreichische Forschungsförderungsgesellschaft (FFG) Bridge 1 Projekt 853209 "ENTWICKLUNG EINES DIAGNOSTISCHEN TESTKITS FÜR NEUROLOGISCHE AUTOIMMUNERKRANKUNGEN (EDNA)"
- 2016: Österreichische Multiple Sklerose Forschungsgesellschaft: "Clinical, morphologic and biochemical markers at different stages of multiple sclerosis (MS) and their dynamics over time"

Research group Neurocritical Care and Infectious Diseases of the Nervous System

Clinical Neurocritical Care Medicine

- NOSTRA 2 NO Synthase Inhibitor in TBI - a microdialysis trial, phase 2 study COSBID in TBI and ICH Tau in aSAH
- Center TBI
- Neuropsychological longterm outcome and neuro-imaging in aSAH patients
- The role of Remote Ischemic Preconditioning in the prevention of ischemic brain damage during intracranial Aneurysm Treatment (RIPAT)
- SWITCH : decompressive craniectomy in ICH
- NEWTON: intraventricular Nimodipine in aneurysmatic SAH
- NOSTRA 3: NO Synthase Inhibitor in TBI -prospective randomized phase 3 study
- Influence of nutrition - in neurocritical care patients - on glucose homeostasis, a cerebral and subcutaneous microdialysis study
- Phast Trac Studie

Translational Neurocritical Care Medicine

- Cerebral microdialysis in murine sepsis syndrome
- Sepsis-Otopathy: hearing impairment in murine (CLP) sepsis
- Experimental SAH - neuroprotective effects of nimodipine in murine SAH

Tropical and Infectious Disease Neurology

- PET in arboviral encephalitides (TBE and Japanese Encephalitis viruses) - a trinationel (Austria, Thailand, Malaysia) study
- Hearing loss in murine cerebral malaria
- Nodding Syndrome: validation of WHO-Definition
- Nodding Syndrome: prevalence in Mahenge, Tanzania - a door to door survey
- Nodding Syndrome, long-term course (10 years evaluation) in Tanzania
- Longterm hearing impairment in Gabonese children with severe Pf. malaria

Research Group Movement Disorders

- EU (HORIZON2020 EC project Grant 633190 - FAIR-PARK II) - Conservative iron chelation as a disease modifying strategy in PD (FAIR-PARK II) (226.735 € projected) -2015-

- ParkinsonFonds Österreich - Ophthalmological disorders in Parkinson's disease: prevalence and clinical impact 166.650 € -2016-

Research Group Sleep Medicine

- I 21 20 B 27 01/2015-01/2018: Safer Screening for RBD, funding from FWF Bilateral Austria/Argentina. Project Leader: Birgit Högl
- 11/2012-10/2016: RLS-Iron: Investigation of iron metabolism in patients with idiopathic RLS, funding from the Government of Tyrol, translational research fund. Global project Leader Birgit Högl
- KLI 236 (former KLI 112) 2012-2016: Motor activity during sleep in health and disease Funded by FWF, Project Leader Birgit Fauscher. formally transferred to Gregor Wenning in 2012

Division of Neurobiology

- Stefanova N & Wenning GK. Alpha-synuclein: a pathogenic trigger and interventional target Pathogenic role of alpha-synuclein in MSA. FWF SPIN DK W1206-08, 180.000 € (PI: Nadia Stefanova)
- ARTEMIS: Targeting alpha-synuclein for treating MSA, E-RARE, FWF I2102, 308.500€ (PI: Gregor K. Wenning)
- Inside the gait - a new era on the horizon for atypical parkinsonian disorders, MSA Coalition, 50.000 USD (PI: Gregor K. Wenning)
- Global MSA Registry & Natural History Study, MSA Coalition, 50.000USD, (PI: Gregor K. Wenning)
- Targeting alpha-synuclein pathology with the molecular tweezer CLR01 in MSA, MSA Coalition, 100.000 USD (PI: Nadia Stefanova)
- Alpha-synuclein: a pathogenic trigger and interventional target in MSA. FWF SFB F4414, 479.955 € (deputy speaker and PI: Nadia Stefanova, co-PI: Gregor K. Wenning)
- Progression of microglial activation in a mouse model of MSA. FWF SPIN DK W1206-08, 150.000 € (PI: Nadia Stefanova)
- MultiSyn: Multimodal Imaging of rare Synucleinopathies, HEALTH-F5-2013-602646, 537.410 €, (PI: Gregor K. Wenning)
- Wenning GK. Cardiac Magnetic Resonance Spectroscopic Correlates of Cardiac Sympathetic Denervation in Parkinson's disease: A Comparison with MSA-P and Healthy Controls, KLI380 109.620 €
- Stefanova N. Alpha-Synuclein and Oligodendrogliin in MSA Pathogenesis, FWF P25161 302.773 €
- Wenning GK & Stefanova N. Functional read-outs and novel interventional targets in a transgenic MSA model, FWF SFB F4404 364.790 €

Computational Neuroscience

- Hochschulraumstrukturmittel - Projekt: Neuroimage Wien Innsbruck Graz (WING)
- Austrian Wirtschaftsservice P1504563-WZP01

Research Group Cognitive Neurology and Neuropsychology

Project leader: Laura Zamarian
MUI-Start Projekt (2014-05-001) „Decision making abilities in patients with multiple sclerosis - Assessment and training“

Collaborations

Research Group Movement Disorders

- Prof. Christopher Goetz, Department of Neurological Sciences, Rush University Medical Center, Chicago, Illinois, USA
- Prof. Cristina Sampaio, CHDI Management/CHDI Foundation, Princeton, New Jersey, USA
- Prof. Eduardo Tolosa, 4Parkinson's Disease and Movement Disorders Unit, Neurology Service, Hospital Clinic de Barcelona, Universitat de Barcelona,
- Prof. Alex Iranzo, Neurology Service, Hospital Clínic de Barcelona, IDIBAPS, CIBERNED, C/Villarroel 170, Barcelona 08036, Spain
- Prof. Juliane Winkelmann, Klinik und Poliklinik für Neurologie, Klinikum rechts der Isar, Technische Universität München, Munich, Germany
- Prof. Susan Fox, Movement Disorder Clinic, Dept. of Medicine, University of Toronto, Canada
- Prof. Tilo van Eimeren, Department of Nuclear Medicine & Department of Neurology, University of Cologne, Germany
- Prof. Thomas Warner, UCL Institute of Neurology, London, United Kingdom
- Dr Pedro Barbosa, UCL Institute of Neurology, London, United Kingdom
- Dr Ana Rosso, Federal University of Rio de Janeiro (UFRJ), Rio de Janeiro, Brazil
- Dr Flavio de Renze Costa, Federal University of Rio de Janeiro (UFRJ), Rio de Janeiro, Brazil
- Dr Sean O'Sullivan, Department of Neurology, Cork University Hospital, Cork, Ireland
- Dr. Eimer Maloney, Department of Neurology, Cork University Hospital, Cork, Ireland
- Dr Bruno Auerbeck, National Institutes of Health, Bethesda,

United States

Research Group Neurocritical Care and Infectious Diseases of the Nervous System

- Craig Anderson, The George Institute for Global Health, Sydney, Australia
- John Stover, Zürich, Switzerland: NOSTRA trialists
- Peter Krensner: Tübingen, Germany and Lambarene, Gabun: SMAC trialists
- Peter Le Roux: Wynnewood, PA, USA, International Multidisciplinary Consensus Conference on Multimodality Neuro-Monitoring.
- JH Zhang: Loma Linda, CA, USA
- Sarah Gabriel, Cystinet-project, Antwerp, Belgium
- Nino Stocchetti, Milano, Italy: SyNAPSE trialists

Research Group Sleep Medicine

- Oscar Gershanik, University of Buenos Aires, Argentina
- SINBAR, Sleep Innsbruck Barcelona
- Joan Santamaria and Alex Iranzo, Hospital Clinic of Barcelona, Barcelona, Spain
- Claudia Trenkwalder, Paracelsus-Elena Clinic, Kassel, and University of Goettingen Germany
- University of Barcelona, Harvard University, Stanford University, Johns Hopkins University, the Rush Medical Center, and other universities in Japan, Latin America etc.

Research Group Multiple Sclerosis and Neuroimmunology

- Hans Lassmann, Monika Bradl, Romana Höftberger, Fritz Leutmezer and Alexander Zimprich, Medical University of Vienna, Vienna, Austria
- Michael Khalil, Christian Enzinger and Franz Fazekas, Medical University of Graz, Graz, Austria
- Kevin Rostasy: Childrens Hospital Datteln, Datteln, Germany
- Edgar Meinel, LMU Munich, Munich, Germany
- Bernhard Hemmer, TU Munich, Munich, Germany
- Sven Jarius and Brigitte Wildemann, University of Heidelberg, Heidelberg, Germany
- Orban Aktas and Hanspeter Hartung, University of Düsseldorf, Düsseldorf, Germany
- Christine Stadelmann and Wolfgang Brück, University of Göttingen, Göttingen, Germany
- Andreas Lutterotti, Mireia Sospreda, Jan Lünemann and Roland Martin, University of Zürich, Zürich, Switzerland
- L. Kappos, University of Basel, Basel, Switzerland
- Romain Marignier, University of Lyon, Lyon, France
- Albert Saiz, Frances Graus, Josep Dalmau and M. Comabella, University of Barcelona, Barcelona, Spain
- Paddy Waters, Jackie Palace, Isabel Leite and Angela Vincent, University of Oxford, Oxford, UK
- Anne Fogdell-Hahn, Karolinska Institute, Stockholm, Sweden
- Eva Havrdova, University of Prague, Prague, Czech Republic
- Jeffrey Bennett, University of Denver, Denver, Colorado
- Douglas Sato, Tatsuuro Misu and Kazuo Fujihara, Tokohu University, Sendai, Japan

Division of Neurobiology

- Gal Bitan, UCLA, Los Angeles, USA
- Angela Cenci, Lund University, Lund, Sweden
- Marina Romero-Ramos, Aarhus University, Aarhus, Denmark
- Leonidas Stefanis, University of Athens Medical School, Athens, Greece
- Wassilios Meisner, University of Bordeaux, Bordeaux, France
- Armin Giese, Ludwig-Maximilian-University, Munich, Germany
- Christian Griesinger, Max Plank Institute for Biophysical Chemistry, Göttingen, Germany
- Thomas Gasser, University of Tübingen, Tübingen, Germany
- Bernd Pichler, University of Tübingen, Tübingen, Germany
- Deniz Kirik, University of Lund, Lund, Sweden
- Horacio Kaufmann, NYU, New York, USA

Computational Neuroscience

- HRSM Wien Innsbruck Graz
- Neuroimage Wien Innsbruck Graz (WING)
- EU Horizon 2020, FAIRPARK II
- PRODEM AUSTRIA (Pospektives Demenzregister der Österreichischen Alzheimer Gesellschaft)
- ENIGMA: Enhancing Neuro Imaging Genetics through Meta Analysis; University of Southern California

Devices and Services

Neurological Research Laboratory (head: ao. Univ.-Prof. Markus Reindl)

Neurosurgery



Director:
Univ.-Prof. Dr. Claudius Thomé

Contact:
Anichstraße 35
6020 Innsbruck

Claudius.Thome@i-med.ac.at
Phone: +43 512 504 27452
Fax: +43 512 504 27453
<http://neurochirurgie.tirol-kliniken.at>

Research Branch (ÖSTAT Classification)

301405, 301904, 302051,
304007, 302048

Keywords

Neuro-oncology, cerebrovascular, neuro-intensive care, neuromonitoring, neuro-trauma, spine surgery, spinal implants, disc degeneration, regenerative medicine

Research Focus

- **Tumour:** enhance resectable tumour volume with aid of intraoperative imaging and fluorescence in combination with electrophysiological stimulation and neuropsychology.
- **Vascular:** prevention and treatment of clinical and experimental cerebral vasospasm after aneurysmal subarachnoid haemorrhage.
- **Spine:** deploy regenerative strategies for discal degeneration and implementation to clinical trials.

General Facts

The Department of Neurosurgery actively hosts investigator-driven academic studies and is recruiting patients in multinational trials in different fields of our daily practice. Clinical research is paralleled with experimental work in our laboratory. We pursue the idea of leading innovative concepts from “bench to bedside”, exemplarily shown in the case of chondrocyte cell transplantation after surgical treatment of lumbar disc herniations. Besides ongoing research focusing on tumour cell infiltration into healthy brain tissue, we implemented different pre- and postoperative routines to determine the “functional status” of patients after treatment of intracranial pathologies. Our main clinical research focuses are divided into three (interacting) groups.

Research

Research Focus: Tumour

The neuro-oncology program of our department is focusing on two main fields of interest, “infiltration” and “optimisation of functional outcomes” of patients after brain tumour surgery. Infiltration is always present in gliomas, whereas metastatic disease of solid cancers was believed to be circumscribed lesions in the brain. The surrounding tissues of metastatic disease and primary gliomas are currently under investigation with ³¹P-Phosphorus-MR-Spectroscopy

and precise biopsies are taken from these regions to demonstrate that infiltrative behaviour in brain tumours (metastasis and gliomas) can be found by state-of-the-art MR-imaging. The borders and surroundings of resected metastases are examined immunohistochemically. Operative techniques are currently under investigation, as in cases of gliomas, fluorescence guided resections and intra-operative imaging with CT is evaluated through posthoc image rendering with prototypic algorithms. The aim of this collaborative project with industrial partners is to predict the extent of tumour resection through intraoperative CT-imaging.

Selected Trials:

- **Elastic Fusion:** intraoperative CT is rendered by prototypic algorithms to generate a “virtual” MRI. The extent of resection is evaluated by neuroradiology (proof of principle)
- **³¹P-MR-Spectroscopy:** several tumour entities are assessed by ³¹P-MR-Spectroscopy to determine “hot-spots” of enhanced metabolic activity
- **Biopsy:** regions of high phosphorus levels (high ATP-levels) are precisely targeted by a navigated biopsy to correlate P-concentration with histologic patterns.
- **METIS:** a multinational, multi-centric trial to assess efficacy of Tumour-Treating-Fields for treatment of brain metastasis after radiosurgical intervention.
- **ReSURGE:** a multi-centre trial designed to evaluate the beneficial effect of surgery for recurrent high-grade gliomas.
- **Ischemic preconditioning** of patients undergoing surgical resection for at least one brain tumour. It aims at the reduction of perilesional ischemic zones.
- **Influence of Methadon** in combination with Temozolomide on glioblastoma cell lines – a laboratory investigation in cooperation with the University of Regensburg, Prof. A. Brawanski.

Research Focus: Vascular/ Neurotrauma/Intensive Care

In addition to prospective analysis of treatment results of vascular pathologies (aneurysms, arteriovenous malformations and stroke) and the ongoing improvements in technical standards and operative techniques, the use of hypoxic preconditioning and serum biomarkers are investigated to beneficially influence patient treatment. The Department of Neurosurgery is participating in several international registries and is in close collaboration with the Department of Neurology. Invasive multimodal

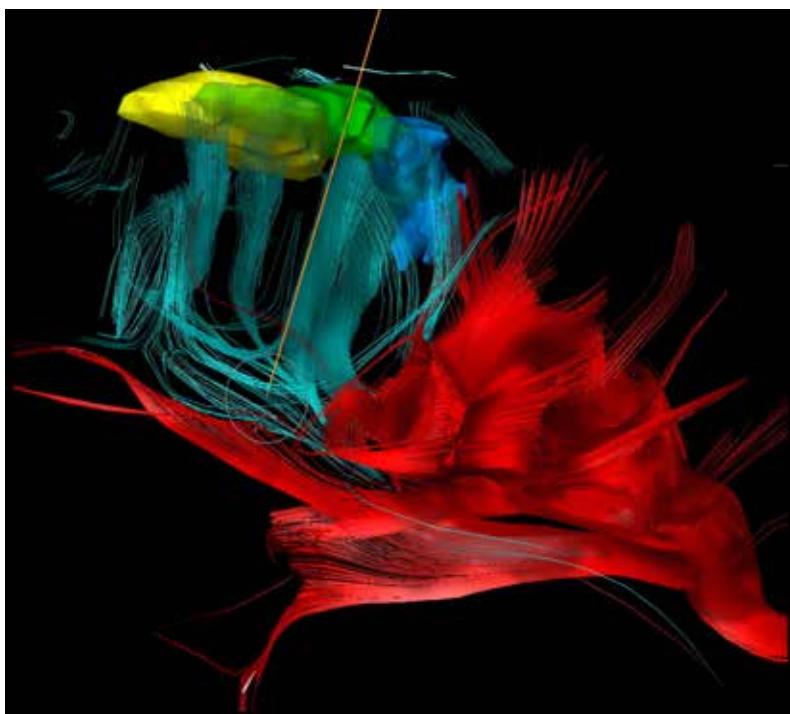

Fig. 1: Multimodal treatment plan for the resection of a solid brain tumour.

monitoring of brain oxygenation, metabolism and blood flow, in combination with intracranial pressure is performed to evaluate the use of these invasive techniques on patient outcome after severe head trauma and subarachnoid haemorrhage. Researchers from the Department are currently working in close collaboration with the Mayo Clinic in Rochester, Minnesota and the Zhang research lab in Loma Linda, California.

Severe head injury is a common medical condition at our department. In addition to multimodal monitoring and pathophysiological investigations, a mono-centric study was launched in close collaboration with the Departments of Neuroradiology and Neurology to determine the use and interpretation of early MRI data and their correlation to serum biomarkers of brain injury. Furthermore, treatment of chronic subdural hematomas, a widely underestimated disease predominantly arising in the elderly, was analysed based on a mono-centric randomised protocol.

Selected Trials:

- NICAPLANT: Phase IIa trial of Nicardipine prolonged release pellets in aneurysmatic subarachnoid haemorrhage.
- TIBI: multimodal invasive neuromonitoring in patients with severe head trauma in combination with early MRI data and serum biomarkers of neuronal injury.

- MISA: prospective cohort trial of ^{31}P -MR-spectroscopy in patients undergoing treatment for incidental and ruptured aneurysms. It includes plasma and CSF biomarker analysis to determine factors associated with delayed cerebral ischemia.
- German Cranioplasty Register – active participation in this bilateral register for patients undergoing cranioplasty after decompressive surgery.
- Cerebellar hematomas – several surveys and prospective multinational cohort studies.

Research Focus: Spine

In accordance with our experimental research of spinal pathologies, our spine group is leading ongoing regenerative studies such as the N-DISC trial. Human (autologous) chondrocytes are cultivated from herniated disc material and re-injected three months after standard surgery. This is the first clinical trial also investigating prophylactic treatment of degenerated discs. Another main (clinical) research interest is based on minimally invasive surgery using state-of-the-art neuro-navigation systems and imaging technology. Recurrent pathologies (i.e., re-herniation of lumbar discs) might be reduced by closure of substance defects in the annulus fibrosus. We collaborate with industrial partners to approve

the use of closure devices to reduce recurrences (Barricaid) and have conducted experimental studies to elucidate the benefits of regenerative approaches. Clinical studies on corpectomies and instrumentation procedures are supplemented with biomechanical studies to determine the stability and durability of spinal implants needed for surgical stabilisation of the human spine in close collaboration with the Department of Trauma Surgery. Recently established cooperations including the Härtl-lab at Weill-Cornell University, New York, USA.

Selected Trials:

- N-DISC: autologous chondrocyte cells to be re-injected in the patient's intervertebral disc several weeks after surgery to prevent ongoing degeneration.
- Barricaid: a composite material annulus closure device is implanted during standard surgery for lumbar disc herniation.
- DynorFuse: a multinational trial to investigate the effectiveness of rigid vs. dynamic fusion techniques in patients with spinal stenosis and mild signs of instability.
- ForaC: a multi-center randomised trial on anterior versus posterior approaches for cervical foraminal stenosis with radiculopathy.
- Implantation of tissue-engineered intervertebral discs in a porcine animal model – laboratory investigation in cooperation with the Weill-Cornell University, Prof. R. Härtl, New York, USA
- Biomechanical and clinical evaluations of alternative screw placement in cervical and lumbar spine.

The experimental focus of the spine group is biological treatment approaches for intervertebral disc degeneration (IVD). IVD, often accompanied by inflammatory and patho-immunological processes, has been described as structural failures of disc tissues. Current treatment approaches are restricted to symptomatic therapies and do not address the option of biological repair of the discs. Intervertebral disc cells play a central role in the maintenance of discs by coordinating the expression of anabolic, catabolic, anti-catabolic and inflammatory cytokines affecting the extracellular matrix. Our electronic database search has identified several target genes that could have a significant impact on disc matrix anabolism and catabolism. By combinatorial relative mass value evaluations of the identified target proteins in degenerative lumbar and cervical discs, we have ascertained imbalanced protein expression patterns of certain anabolic, catabolic, anti-catabolic and

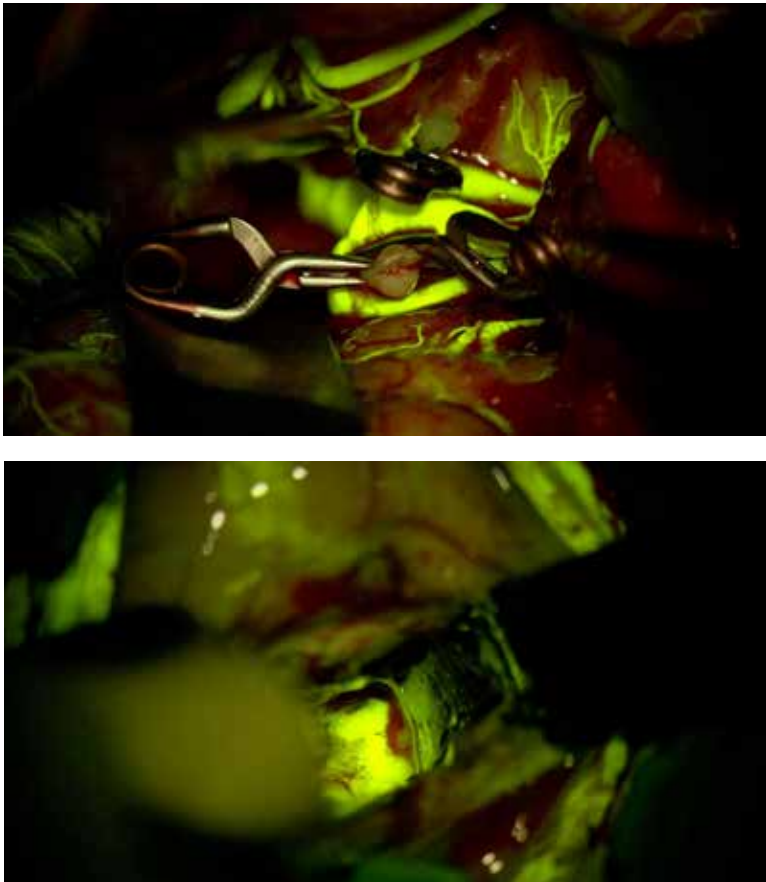

Fig. 2: Intraoperative fluorescence of a clipped aneurysm (to confirm complete repair) and a malignant brain tumour (to delineate the lesion from healthy brain tissue).

inflammatory cytokines. Our progressive characterisation of the target genes give us the opportunity to develop new therapeutic approaches. Currently, we are establishing an adeno-associated virus (AAV) based gene therapeutic system as a new biological treatment approach for degenerative disc diseases. So far, AAV serotypes with human IVD tissue tropism have not been identified and characterised. The use of AAV-mediated gene therapy for human intervertebral disc research has not yet been investigated.

Selected Publications

The value of quantitative sensory testing in spine research

Tschugg, Anja, Löscher, Wolfgang N., Lener, Sara, Hartmann, Sebastian, Wildauer, Matthias, Neururer, Sabrina, Thomé, Claudius, NEUROSURGICAL REVIEW: 2016; [Epub ahead of print]: S.

Improvement of sensory function after sequestrectomy for lumbar disc herniation: a prospective clinical study using quantitative sensory testing

Tschugg, Anja, Lener, Sara, Hartmann, Sebastian, Neururer, Sabrina, Wildauer, Matthias, Thome, Claudius, Loescher, Wolfgang N., EUROPEAN SPINE JOURNAL: 2016; 25: S. 3543-3549

A prospective multicenter phase I/II clinical trial to evaluate safety and efficacy of NOVOCART Disc plus autologous disc chondrocyte transplantation in the treatment of nucleotomized and degenerative lumbar disc to avoid secondary disease: study protocol for a randomized controlled trial

Tschugg, Anja, Michnacs, Felix, Strowitzki, Martin, Meisel, Hans Joerg, Thome, Claudius, TRIALS: 2016; 17: S. 108

Cervical corpectomies: results of a survey and review of the literature on diagnosis, indications, and surgical technique

Hartmann, Sebastian, Tschugg, Anja, Obernauer, Jochen, Neururer, Sabrina, Petr, Ondra, Thome, Claudius, ACTA NEUROCHIRURGICA: 2016; 158: S. 1859-1867

Retinal Vessel Analysis (RVA) in the Context of Subarachnoid Hemorrhage - A Proof of Concept Study

Albanna, Walid, Conzen, Catharina, Weiss, Miriam, Clusmann, Hans, Fuest, Matthias, Mueller, Marguerite, Brockmann, Marc Alexander, Vilser, Walthard, Schmidt-Trucksass, Arno, Hoellig, Anke, Seiz, Marcel, Thome, Claudius, Kotliar, Konstantin, Schubert, Gerrit Alexander, PLOS ONE: 2016; 11: S. e0158781

Intradural synovial cyst of the atlantoaxial joint: a case report

Hartmann, Sebastian, Tschugg, Anja, Kavakebi, Pujan, Thome, Claudius, ACTA NEUROCHIRURGICA: 2016; 158: S. 1583-1586

Spreading depolarizations in patients with spontaneous intracerebral hemorrhage: Association with perihematomal edema progression.

Helbok, R., Schiefecker, A.J., Friberg, C., Beer, R., Kofler, M., Rhomberg, P., Unterberger, I., Gizewski, E., Hauerberg, J., Möller, K., Lackner, P., Broessner, G., Pfausler, B., Ortler, M., Thome, C., Schmutzhard, E., Fabricius, M., JOURNAL OF CEREBRAL BLOOD FLOW AND METABOLISM: 2016; [Epub ahead of print]: S. 271678X16651269

Opening the Internal Hematoma Membrane Does Not Alter the Recurrence Rate of Chronic Subdural Hematomas: A Prospective Randomized Trial

Unterhofer, Claudia, Freyschlag, Christian F., Thome, Claudius, Ortler, Martin, WORLD NEUROSURGERY: 2016; 92: S. 31-36

Cervical arthroplasty with ROTAIO(R) cervical disc prosthesis: first clinical and radiographic outcome analysis in a multicenter prospective trial

Obernauer, J., Landscheidt, J., Hartmann, S., Schubert, G. A., Thome, C., Lumenta, C., BMC MUSCULOSKELETAL DISORDERS: 2016; 17: S. 11

Analysis of a performance-based functional test in comparison with the visual analog scale for postoperative outcome assessment after lumbar spondylodesis

Hartmann, Sebastian, Hegewald, Aldemar Andres, Tschugg, Anja, Neururer, Sabrina, Abenhardt, Michael, Thome, Claudius, EUROPEAN SPINE JOURNAL: 2016; 25: S. 1620-1626

Identification and characterization of human nucleus pulposus cell specific serotypes of adeno-associated virus for gene therapeutic approaches of intervertebral disc disorders

Mern, Demissew S., Thome, Claudius, BMC MUSCULOSKELETAL DISORDERS: 2015; 16: S. 341

Dual Anti-angiogenic Chemotherapy with Temozolomide and Celecoxib in Selected Patients with Malignant Glioma Not Eligible for Standard Treatment

Kerschbaumer, Johannes, Schmidt, Franziska Anna, Grams, Astrid Ellen, Nowosielski, Martha, Pinggera, Daniel, Brawanski, Konstantin Robert, Petr, Ondra, Thome, Claudius, Tuettenberg, Jochen, Seiz, Marcel, Freyschlag, Christian Franz,

ANTICANCER RESEARCH: 2015; 35: S. 4955-4960

Biomechanical testing of circumferential instrumentation after cervical multilevel corpectomy

Hartmann, Sebastian, Thome, Claudius, Keiler, Alexander, Fritsch, Helga, Hegewald, Aldemar Andres, Schmoelz, Werner, EUROPEAN SPINE JOURNAL: 2015; 24: S. 2788-2798

Safety and efficacy of microsurgical treatment of previously coiled aneurysms: a systematic review and meta-analysis

Petr, Ondra, Brinjikji, Waleed, Thome, Claudius, Lanzino, Giuseppe, ACTA NEUROCHIRURGICA: 2015; 157: S. 1623-1632

Gender Influences Radicular Pain Perception in Patients with Lumbar Disc Herniation

Tschugg, Anja, Loescher, Wolfgang N., Hartmann, Sebastian, Neururer, Sabrina, Wildauer, Matthias, Thome, Claudius, JOURNAL OF WOMENS HEALTH: 2015; 24: S. 771-776

A Sandwich Technique for Prevention of Cerebrospinal Fluid Rhinorrhea and Reconstruction of the Sellar Floor after Microsurgical Transsphenoidal Pituitary Surgery

Freyschlag, Christian F., Goerke, Stephanie Alice, Obernauer, Jochen, Kerschbaumer, Johannes, Thome, Claudius, Seiz, Marcel, JOURNAL OF NEUROLOGICAL SURGERY PART A-CENTRAL EUROPEAN NEUROSURGERY: 2016; 77: S. 229-232

Calcium-binding proteins in focal cortical dysplasia

Kuchukhidze, Giorgi, Wieselthaler-Hoelzl, Anna, Drexel, Meinrad, Unterberger, Iris, Luef, Gerhard, Ortler, Martin, Becker, Albert J., Trinka, Eugen, Sperk, Guenther, EPILEPSIA: 2015; 56: S. 1207-1216

Long-Term Follow-Up of Motor Cortex Stimulation for Neuropathic Pain in 23 Patients

Slotty, Philipp J., Eisner, Wilhelm, Honey, Christopher R., Wille, Christian, Vesper, Jan, STEREOTACTIC AND FUNCTIONAL NEUROSURGERY: 2015; 93: S. 199-205

Neuroprotective Strategies after Neonatal Hypoxic Ischemic Encephalopathy

Dixon, Brandon J., Reis, Cesar, Ho, Wing Mann, Tang, Jiping, Zhang, John H., INTERNATIONAL JOURNAL OF MOLECULAR SCIENCES: 2015; 16: S. 22368-22401

What's New in Traumatic Brain Injury: Update on Tracking, Monitoring and Treatment

Reis, Cesar, Wang, Yuechun, Akyol, Onat, Ho, Wing Mann, Applegate, Richard, II, Stier, Gary, Martin, Robert, Zhang, John H., INTERNATIONAL JOURNAL OF MOLECULAR SCIENCES: 2015; 16: S. 11903-11965

Safety and efficacy of treatment strategies for posterior inferior cerebellar artery aneurysms: a systematic review and meta-analysis

Petr, Ondra, Sejkorova, Alena, Bradac, Ondrej, Brinjikji, Waleed, Lanzino, Giuseppe, ACTA NEUROCHIRURGICA: 2016; 158: S. 2415-2428

Safety and efficacy of endovascular treatment for intracranial infectious aneurysms: A systematic review and meta-analysis

Petr, Ondra, Brinjikji, Waleed, Burrows, Anthony M., Cloft, Harry, Kallmes, David F., Lanzino, Giuseppe, JOURNAL OF NEURORADIOLOGY: 2016; 43: S. 309-316

Current Trends and Results of Endovascular Treatment of Unruptured Intracranial Aneurysms at a Single Institution in the Flow-Diverter Era

Petr, O., Brinjikji, W., Cloft, H., Kalimes, D. F., Lanzino, G., AMERICAN JOURNAL OF NEURORADIOLOGY: 2016; 37: S. 1106-1113

Selected Funding

Diverse Industry sponsored and academic clinical trials

Collaborations

Numerous research collaborations with institutions in Austria and neighboring countries in the fields of neurooncology (i.e. Vienna, Regensburg, Heidelberg), cerebrovascular neurosurgery (i.e. Aachen, Düsseldorf, Berlin) and regenerative medicine (i.e. Berlin, Mannheim). The multicenter clinical trials involve numerous partners throughout Europe. Researchers are currently staying at the Mayo Clinic, Rochester, MS/USA and in Loma Linda, CA/USA within the scope of ongoing cooperations.

Obstetrics and Gynecology



Director:
Univ.-Prof. Dr. Christian Marth

Contact:
Anichstraße 35
6020 Innsbruck

Christian.Marth@i-med.ac.at
Phone: +43 512 504 23051
Fax: +43 512 504 23055
<https://frauenheilkunde-innsbruck.tirol-kliniken.at>

Research Branch (ÖSTAT Classification)

302022, 302017, 302055, 301306

Keywords

Clinical studies, Gynaecologic Oncology, Senology, Biobanking, Translational Research, Biomarker-identification

Research Focus

- Clinical and pre-clinical studies in women specific cancer in regard to prevention, diagnostics, therapy and follow-up care
- Translational research
- Collection of biosamples (tissues, serum, ascites, ...)
- Biomarker identification in breast and gynaecological malignancies
- Specialist interest in increasing understanding of the development of women specific cancer
- Pregnancy Research

General Facts

The clinical trials conducted at the Department in collaboration with other task forces and research groups within the clinic but also internationally are coordinated by AGO Studienzentrale as trial office of the non-profit organization AGO Austria (Association of gynaecologic oncology in Austria). The aim is to promote and advance gynaecologic (especially ovarian and breast) cancer research regarding prevention, diagnostics, therapy and follow-up care. Current trials involve targeted therapies e.g. PARP or PI3K inhibitors, as well as novel cytotoxic substances and antibody-drug conjugates. Chemotherapy based and surgical trials for other gynaecologic malignancies are also being assessed.

The pre-clinical studies are conducted mainly in the Laboratory of Clinical Biochemistry (Head: Heidi Fiegl) and in the Morphological Laboratory (Head: Christian Marth; responsible pathologist: Afschin Soleiman). Both laboratories are certified according to ISO 9001:2008 and house the biobank of this Department which contains FFPE tissue samples from nearly 6.500 patients, fresh frozen tissue samples from over 1.000 patients, ascites samples from over 1.500 patients and serum samples (pre-therapeutic samples and samples drawn during the follow-up period from over 3.000 patients). Biobanking is performed there since the 1980s and has been optimized over the years.

Research

Clinical Trials: Gynaecologic Oncology

Leader: Christian Marth

A number of gynaecologic cancer trials (surgical and therapeutic trials) are being conducted in our department to assess efficacy and safety of different types of therapies e.g. VEGF, Anti-angiogenic, Hsp90, MEK and PARP-Inhibitors. These trials are conducted in ovarian, endometrial and cervical cancer, as well as other gynaecologic diseases such as vulvar intraepithelial neoplasia.

Selected trials are described below:

- Our department was participating in the phase 3 randomized double-blind AGO 40 NOVA trial which evaluated the efficacy of the PARP inhibitor Niraparib compared to placebo as maintenance therapy in patients with platinum-sensitive ovarian cancer. The duration of progression-free survival (PFS) was significantly longer in the Niraparib group than in the placebo group, regardless of the presence or absence of germline BRCA mutations or homologous recombination deficiency status. Due to this trial Niraparib has been approved for the maintenance treatment for patients with recurrent ovarian cancer in the US and the approval in Europe is expected shortly.
- The AGO 47 PAOLA-1 trial is a randomized, double-blind, phase III trial assessing the efficacy of the PARP inhibitor Olaparib vs. placebo in the maintenance treatment of patients with advanced FIGO stage IIIb-IV high-grade serous or endometrioid ovarian, fallopian tube or peritoneal cancer. All patients will need to have been treated with standard first-line treatment, combining platinum-taxane chemotherapy with Bevacizumab concurrent with chemotherapy and in maintenance.

Clinical Trials: Breast Cancer

Leader: Christian Marth

The Breast Cancer Care unit was able to successfully participate in several clinical trials in 2015 and 2016, especially also in trials using substances that interact with the cyclin-dependent kinase (CDK) 4 or CDK6 pathway. In the recent years it became evident that among the most important and innovative treatment for patients with breast cancer are these CDK4/6 Inhibitors.

In the following a short selection of the most important clinical trials is shown:

- An adjuvant trial with the CDK Inhibitor Palbociclib with adjuvant endocrine therapy versus endocrine therapy alone for hormone receptor positive (HR+)/

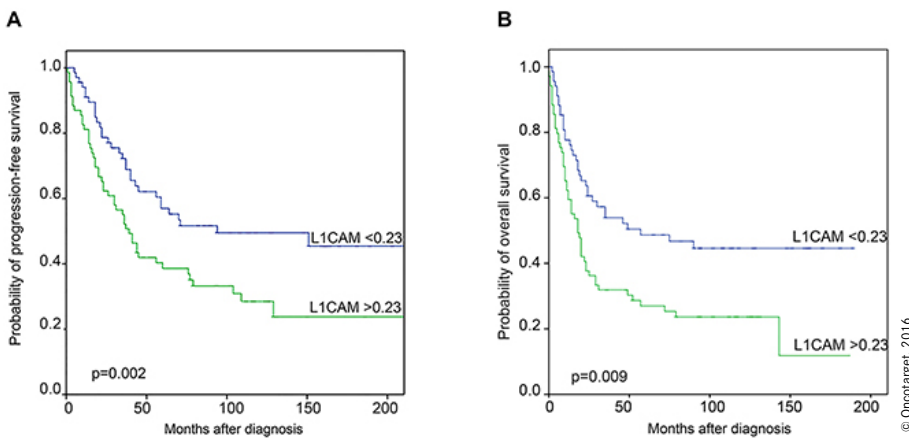

Fig. 1: Kaplan Meier survival analysis and L1CAM mRNA expression. A. Progression-free and B. Overall survival in 138 ovarian cancer patients according to the median L1CAM mRNA expression as cut-off value.

presence and relevance in ovarian cancer.

Gamma-glutamyltransferase (GGT) in breast cancer

Leader: Nicole Concin

GGT is a known marker for apoptotic balance and cell detoxification. Elevated GGT serum levels are associated with increased risk of overall cancer incidence and several site-specific malignancies.

- In a prospective study in two patient cohorts with over 100,000 participants, GGT was identified as an independent risk factor for breast cancer beyond the consumption of alcohol and other life style risk factors.
- In a multicentre study the association of pre-therapeutic GGT levels, clinical-pathological parameters and survival in 114 patients with primary metastatic breast cancer were assessed. Pre-therapeutic GGT serum level might serve as a novel prognostic factor for OS in these patients.

Impact of aluminium on breast cancer

Leader: Nicole Concin

To clarifying recently raised issues relating underarm antiperspirants containing aluminium salts with breast cancer, history of underarm cosmetic products use and aluminium concentration was assessed in breast cancer patients and age-matched healthy women.

L1CAM Expression

Leader: Alain Zeimet

- Recently, L1CAM immunohistochemical (IHC) evaluation showed a unique value to predict the outcome of early endometrial cancer. However IHC results are often conflicting for lack of inter-laboratory standardisation. Therefore, as a proof of concept, quantitative real-time PCR (qRT-PCR) was used to analyse L1CAM mRNA expression and showed a high overall concordance with IHC staining.
- In a retrospective study L1CAM mRNA expression was examined in fresh frozen tissue samples from 138 patients with FIGO I-IV stage ovarian cancer to define its relevance in ovarian cancer biology. High L1CAM mRNA expression was associated with PFS and OS (Figure 1). A significant positive correlation between L1CAM mRNA expression and tumour grade, FIGO stage as well as the histological subtype was found. L1CAM mRNA expression appears to play a substantial role in the pathophysiology of ovarian cancer.

human epidermal growth receptor 2 (HER2)-negative early breast cancer, and a randomized double-blinded, placebo controlled study of Ribociclib in combination with Fulvestrant for the treatment of postmenopausal woman with hormone receptor positive, HER2-negative, advanced breast cancer who have received no or only one line of prior endocrine treatment are also investigated at our department in the hopes to advance the research of new treatment options to patients with breast cancer.

- The ABCSG-18 trial, a prospective, randomized, placebo-controlled, double-blind phase 3 study, investigated the effects of adjuvant anti-RANK ligand antibody Denosumab on fractures and other bone health parameters, and on safety outcomes, in postmenopausal patients with early-stage HR+ BC receiving treatment with aromatase inhibitors (AI). It was shown that that adjuvant Denosumab significantly reduces AI-induced fractures in these patients.
- A Phase 2 Neoadjuvant Trial in Postmenopausal Woman with Hormone Receptor Positive, HER2 Negative Breast Cancer was the NeoMONARCH trial. It compared the biological effects of Abemaciclib (LY2835219) in Combination with Anastrozole to those of Abemaciclib Monotherapy and Anastrozole Monotherapy and evaluated the clinical activity and safety of a subsequent therapy with Abemaciclib in combination with Anastrozole.

GANNET53 (EU project)

Leader: Nicole Concin

Epithelial ovarian cancer (EOC) is the most lethal gynaecological malignancy. The pre-

dominance of aggressive type II tumours, which are characterized by a high frequency of p53 mutations, and primary or acquired resistance to platinum-based chemotherapy profoundly contribute to the high mortality rate. Addressing this need for more effective treatment strategies to improve the dismal survival in these patients, the GANNET53 trial (Ganetespib in metastatic, p53 mutant, platinum-resistant ovarian cancer) was conducted. GANNET53 is a Europe-wide, multi-centre Phase I and randomized Phase II clinical trial, targeting mutant p53, via an innovative new Hsp90 (heat shock protein 90) inhibitor in platinum-resistant EOC patients. The consortium consists of clinical trial groups in gynaecological oncology, university centres as well as noted p53 scientists and three innovative enterprises. We aim to substantially improve overall survival (OS) in EOC patients with metastatic type II platinum-resistant tumours. On the molecular level we aim to identify the tumours mutational status in all GANNET53 study patients.

A sub-project is dealing with prion-like aggregation of p53 protein in ovarian cancer. There is a growing number of evidence indicating cancer as one of a protein aggregation disease. Recently, p53 protein has been shown as amyloid forming protein. Furthermore, it has been suggested that dominant-negative and gain-of-function effects of p53 mutant result from its increased aggregation propensity. Therefore, prion-like behaviour of p53 may play a crucial role in initiation and progression of cancer. The aims of this study are to establish reliable methodology to detect p53 prion-like aggregates and to analyse their

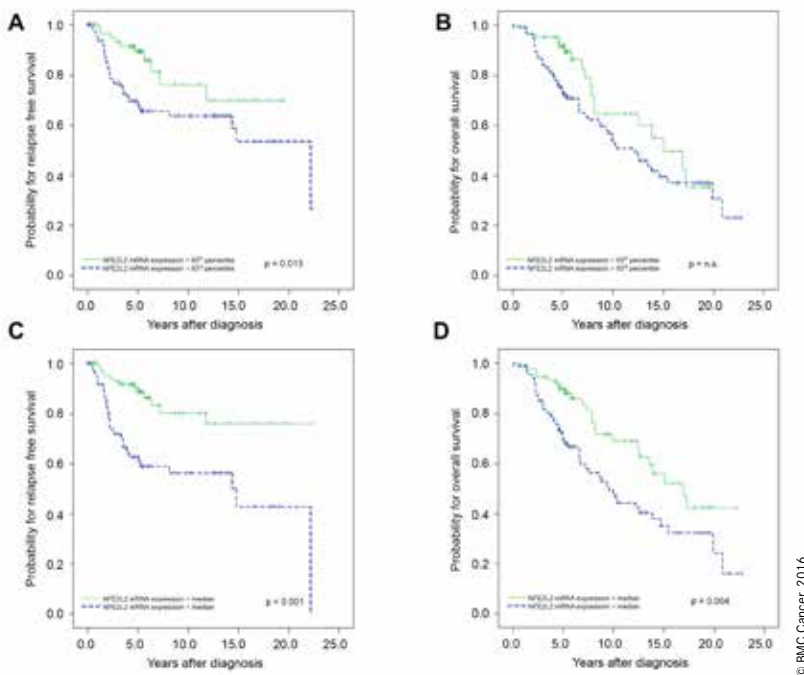

Fig. 2: Kaplan Meier survival analysis and NFE2L2 mRNA expression in 176 breast cancer patients. A. Relapse-free survival and B. overall survival in 176 breast cancer patients according to the 65th percentile as cut-off value as identified by Youden's index. (c) Relapse-free survival and (d) overall survival in 176 breast cancer patients according to the median as cut-off value

DNA methylation and mRNA expression analyses in ovarian cancer

Leader: Alain Zeimet, Daniel Reimer

- The clinical relevance of FOLR1 mRNA expression and DNA methylation (DNAm) was assessed in 254 type I and type II ovarian cancers, and 60 normal fallopian or ovarian epithelial tissues. No correlations were found between FOLR1 expression and its DNAm. In type I cancers, strong FOLR1 expression has been found to be a reliable indicator of improved platinum responsiveness.
- In another study the clinical relevance of miR34a was analysed in 133 ovarian cancers. The expression of miR-34a was found to be lower in type II ovarian cancers, in TP53 mutated tumours and in high grade cancers. In multivariate survival analysis low expressing miR-34a cancers exhibited a reduced PFS and OS.

Biomarker identification in cancer

Leader: Heidi Fiegl

A selection of the most important projects is shown:

- The transcription factor nuclear factor erythroid 2-related factor 2 (NFE2L2) is a crucial regulator of the intracellular antioxidant response. In a retrospective study comprising NFE2L2 mRNA expres-

sion data from the Molecular Taxonomy of Breast Cancer International Consortium (METABRIC; n=1942) and from 176 breast cancer tissues from the biobank of the Department, a reduced NFE2L2 mRNA expression was identified as an independent predictor of shortened survival in breast cancer patients (Figure 2).

- The potassium channel gene KCNJ3 (encoding for GIRK1 proteins) has been reported to be upregulated in tumours of breast cancer patients and to correlate with positive lymph node status. In collaboration with the Medical University Graz KCNJ3 mRNA expression levels were analysed in different breast cancer subtypes from more than 1000 patients. High KCNJ3 mRNA expression levels were shown to be associated with poor survival in Oestrogen receptor-positive breast cancer patients.
- In collaboration with the University College London the expression of the long non-coding RNA HOTAIR (HOX transcript antisense intergenic RNA), which is involved in mesenchymal stem cell fate and cancer biology, and associated DNAm was analysed and validated in 1080 ovarian cancer cases. HOTAIR expression or its surrogate DNAm signature were predictors for poor survival in

carboplatin-treated patients.

The Copenhagen Index (CPH-I) – a diagnostic index combining HE4, CA125 and age index to optimize referral of women with suspected ovarian cancer.

Leader: Irene Mutz-Dehbalai

In collaboration with the University of Copenhagen an international multicentre study, comprising 2665 patients, was performed to develop and validate a biomarker-based index to optimize referral and diagnosis of patients with suspected ovarian cancer. CPH-I was highly significant in discriminating benign from malignant ovarian disease independently of ultrasound and menopausal status. Therefore it may provide a simple index to optimize referral of women with suspected ovarian cancer.

Human papillomaviruses (HPV) research

Leader: Andreas Widschwendter

In collaboration with the University Clinic of Craniomaxillofacial Surgery it was shown that the prevalence of oral HPV infection was higher in young, sexual active adults compared to other population groups. Tobacco and alcohol may facilitate an oral HPV infection. Also a significant association was found between high-risk oral HPV infection and the presence of oral premalignant lesions.

Pregnancy research

Leader: Angela Ramoni, Sebastian Schröcksnadel, Hans-Peter Krause

- Preeclampsia is a disorder of pregnancy characterized by the onset of high blood pressure and often a significant amount of protein in the urine. In 10-20% of patients with severe preeclampsia the HELLP syndrome (Hemolysis, Elevated Liver enzymes, and Low Platelet count) is diagnosed.
- In collaboration with other gynaecological centres in Austria a HELLP-biobank was conducted where blood, urine, plasma, serum, cord blood and placenta tissues are collected.
 - Increased levels of the anti-angiogenic soluble fms-like tyrosine kinase 1 (sFlt-1) and reduced levels of pro-angiogenic placental growth factor (PlGF) were described in the maternal circulation. In collaboration with several German gynaecological centres, a positive influence of the sFlt-1/PlGF ratio determination on clinical decision-making in women with suspected preeclampsia was shown.

Selected Publications

Clinical impact of L1CAM expression measured on the transcriptome level in ovarian cancer

Abdel-Azim, Samira, Duggan-Peer, Michaela, Sprung, Susanne, Reimer, Daniel, Fiegl, Heidi, Soleiman, Afschin, Marth, Christian, Zeimet, Alain G.,
ONCOTARGET: 2016; 7: S. 37205-37214

Niraparib Maintenance Therapy in Platinum-Sensitive, Recurrent Ovarian Cancer

Mirza, M. R., Monk, B. J., Herrstedt, J., Oza, A. M., Mahner, S., Redondo, A., Fabbro, M., Ledermann, J. A., Lorusso, D., Vergote, I., Ben-Baruch, N. E., Marth, C., Madry, R., Christensen, R. D., Berek, J. S., Dorum, A., Tinker, A. V., du Bois, A., Gonzalez-Martin, A., Follana, P., Benigno, B., Rosenberg, P., Gilbert, L., Rimel, B. J., Buscema, J., Balseer, J. P., Agarwal, S., Matulonis, U. A., ENGOT-OV16 NOVA Investigators,
NEW ENGLAND JOURNAL OF MEDICINE: 2016; 375: S. 2154-2164

Evaluating L1CAM expression in human endometrial cancer using qRT-PCR

Notaro, Sara, Reimer, Daniel, Duggan-Peer, Michaela, Fiegl, Heidi, Wiedermaier, Annamaria, Roessler, Julia, Altevogt, Peter, Marth, Christian, Zeimet, Alain Gustave,
ONCOTARGET: 2016; 7: S. 40221-40232

Long-term significance of urinary neopterin in ovarian cancer: a study by the Austrian Association for Gynecologic Oncology (AGO)

Volgger, B. M., Windbichler, G. H., Zeimet, A. G., Graf, A. H., Bogner, G., Angleitner-Boubenizek, L., Rohde, M., Denison, U., Sliutz, G., Fuith, L. C., Fuchs, D., Marth, C.,
ANNALS OF ONCOLOGY: 2016; 27: S. 1740-1746

Adjuvant denosumab in breast cancer (ABCSG-18): a multicentre, randomised, double-blind, placebo-controlled trial

Gnant, Michael, Pfeiler, Georg, Dubsy, Peter C., Hubalek, Michael, Greil, Richard, Jakesz, Raimund, Wette, Viktor, Balic, Marija, Haslbauer, Ferdinand, Melbinger, Elisabeth, Bjelic-Radistic, Vesna, Artner-Matuschek, Silvia, Fitzal, Florian, Marth, Christian, Sevelid, Paul, Mlineritsch, Brigitte, Steger, Guenther G., Manfreda, Diether, Exner, Ruth, Egle, Daniel, Bergh, Jonas, Kainberger, Franz, Talbot, Susan, Warner, Douglas, Fesl, Christian, Singer, Christian F., Austrian Breast Colorectal Canc St,
LANCET: 2015; 386: S. 433-443

Selected Funding

GANNET53 European Union Seventh Framework Program (FP7) is planned for 5.5 years with a funding of 6 million Euros (Prof. Dr. Nicole Concin).

Collaborations

- Prof. Dr. Robert Zeillinger, Medical University Vienna, Vienna, Austria
- Prof. Dr. Ignace Vergote, Katholieke Universiteit Leuven, Leuven, Belgium
- Dr. Neda Slade, Ruder Bošković Institute, Zagreb, Croatia
- Priv.-Doz. Dr. Roland Reitsamer, Paracelsus Medical University, Salzburg, Austria
- Primar Dr. Arthur Scherer, Medical Services Hospital, Bressanone, Italy
- Primar Dr. Herbert Heidegger, Medical Services Hospital, Meran, Italy
- Prof. Dr. Andreas Obermair, University of Queensland, Brisbane, Australia
- Prof. Dr. Martin Oehler, University of Adelaide, Adelaide, Australia
- Prof. Dr. Martin Widschwendter, University College London, London, United Kingdom
- Dr. Heinrich Roehder, Biodesix, Colorado, USA

Collaborations in Clinical Trials with (inter)national research groups:

- AGO Austria – Arbeitsgemeinschaft Gynäkologische Onkologie
- ENGOT – European Network for Gynecological Oncological Trial groups (Cooperation with 19 trial groups)
- GCIG – Gynecologic Cancer InterGroup (Cooperation with 25 international trial groups)
- ABCSG – Austrian Breast & Colorectal Cancer Study Group

International collaboration with trial groups outside of ENGOT, GCIG or ABCSG trials:

- Prof. Dr. Jalid Sehouli, Charité Berlin, Germany
- Nord-Ostdeutsche Gesellschaft für Gynäkologische Onkologie (NOGGO e.V.)
- EORTC – European Organization for Research and Treatment of Cancer

Gynecological Endocrinology and Reproductive Medicine



Director:
Univ.-Prof.ⁱⁿ Dr.ⁱⁿ Bettina Toth

Contact:
Anichstraße 35
6020 Innsbruck

Bettina.Toth@i-med.ac.at
Phone: +43 512 504 23276
Fax: +43 512 504 23277
www.kinderwunsch-zentrum.at

Research Branch (ÖSTAT Classification)

302089, 302022

Keywords

Reproductive medicine, fertility preservation, endometriosis, PCOS, recurrent miscarriage, gynaecological, endocrinology, early pregnancy, gender identity disorders

Research Focus

Our research focuses on the physiology and pathology of ovarian and uterine function, fertility preservation, early and recurrent pregnancy loss, endometriosis, gynaecological endocrine disorders, contraception and disturbances of gender identity.

General Facts

The research unit is structured around the clinical unit of Gynaecological Endocrinology and Reproductive Medicine. We provide clinical out-patient services with more than 10,000 annual patient contacts for both endocrine- and fertility-related disorders. We perform approximately 300 stimulated IVF/ICSI and more than 100 frozen embryo cycles annually. In addition, we offer oocyte, sperm, embryo and ovarian tissue cryopreservation for patients facing loss of fertility due to autoimmune and malignant diseases. The IVF laboratory, whose principal clinical workload consists of sperm and oocyte preparation, fertilization and culture, and cryopreservation, works hand in hand with our research unit. We collaborate closely with a number of clinical and scientific units of the Medical University of Innsbruck as well as international research partners.

Research

This research report primarily focuses on scientific work which was performed under the supervision of Prof. Dr. Ludwig Wildt, former head of the Department. Prof. Dr. Bettina Toth took over the position in October 2016.

Endometriosis

Beata Seeber, Bettina Böttcher

Endometriosis affects up to 10 % of the female population and can be a debilitating disease marked by pelvic pain and infertility. The aetiology is not completely clear but likely due to a combination of factors including genetic predisposition, retrograde menstruation, and immunologic deficits.

Previous work from our group presented novel theories regarding disease pathogenesis, centred on the concept of tissue injury and repair (TIAR). This concept views endometriosis as well as the closely related adenomyosis as the consequence of repetitive autotraumatization of the uterus caused by exaggerated uterine contractions followed by local injury, induction of prostaglandin synthesis and a further oestrogen-induced increase in the strength of uterine contractions.

Along a similar line, the induction of growth of pain nerve fibres in endometriotic lesions by neurotrophins and their receptors is a topic of interest for our group. We performed immunohistochemistry on superficial and deep infiltrating lesions and, using quantitative computer-driven analyses, showed differences in neurotrophins and their receptors between the two sub-types of endometriosis lesions. Our results suggest differences in pain signal conduction and in the potential for deep infiltration, shedding further light on the molecular biology of this disease.

Altered pain perception in patients with primary and secondary dysmenorrhea has been examined by our group in cooperation with Prof. Gizewski, Department of Neuroradiology: In other chronic pain conditions like irritable bowel disease, a different cerebral processing of pain following a visceral pain stimulus had been shown. Therefore, we aimed to apply this pain model to patients with dysmenorrhea compared to healthy controls using functional magnetic resonance imaging. First data are available but have not been published yet. Another focus of research in this patient cohort is on known co-morbidities such as quality of life, anxiety, and depression.

Polycystic Ovary Syndrome (PCOS)

Beata Seeber, Bettina Böttcher

Polycystic ovarian syndrome is the most frequent endocrine disorder in women of reproductive age, and is associated with clinical hyperandrogenemia (hirsutism, acne) and biochemical elevation of serum testosterone as well as oligo-amenorrhea due to anovulation. Consequently, nearly all women with PCOS suffer from subfertility. In recent years, more attention has been directed to the metabolic disturbances associated with this syndrome, which include insulin resistance, hypercholesterolemia, hypertriglyceridemia and hypertension. Previous publications from our group presented the prevalence of these metabolic

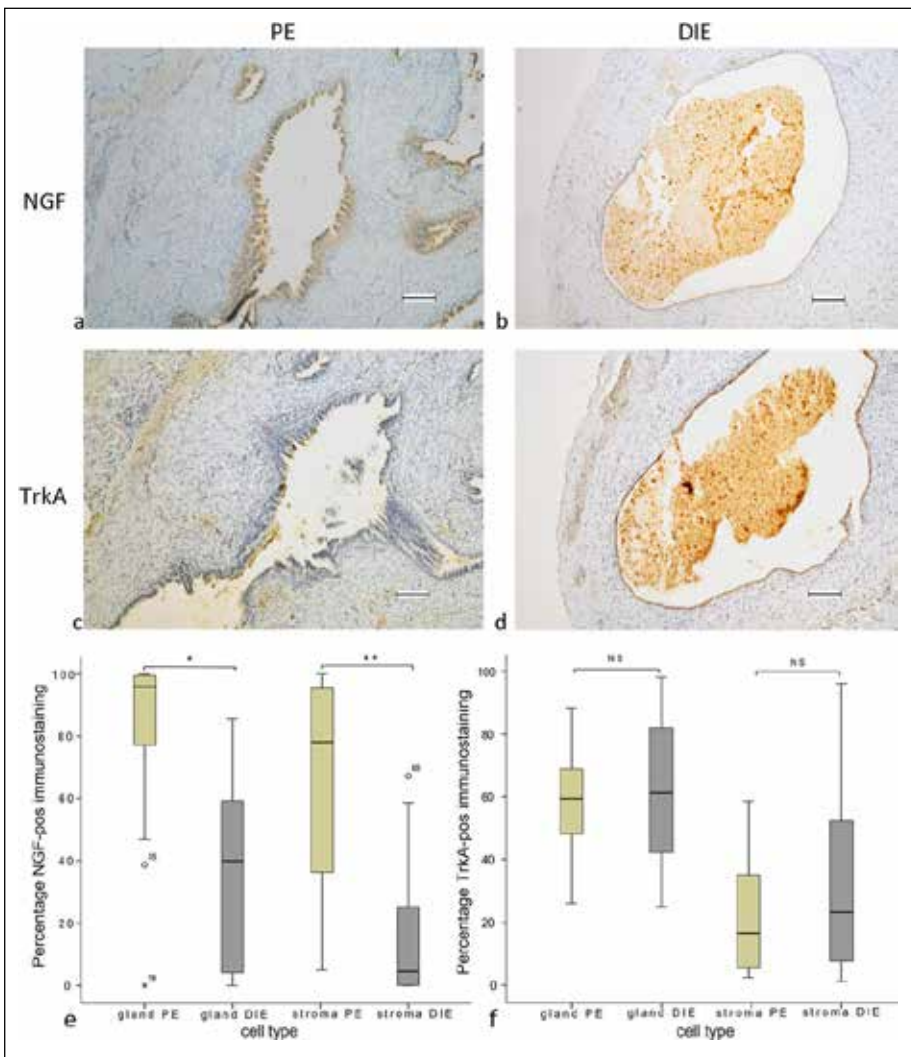

Fig. 1: Histological sections from peritoneal (PE) and deep infiltrating endometriosis (DIE). Immunohistochemistry was performed to stain for nerve growth factor (NGF) and the TrkA neurotrophin receptor. The percentage of NGF positive immune staining cells in stroma as well as glandular tissue showed significant differences between PE and DIE. In contrast, no differences were seen in TrkA-positive immunostaining.

disturbances in our central European populations and studied potential predictive markers. In recent years, we have focused our efforts on the study of follicular granulosa cells from women with PCOS. Using *in vitro* stimulation experiments, we reported that these cells differ at fundamental level from granulosa cells of controls and may explain the high prevalence of certain IVF-related complications, such as ovarian hyperstimulation syndrome, in women with PCOS.

Using a questionnaire battery we analysed life quality, anxiety, and depression in this patient cohort and found a significantly reduced quality of life especially in regard to

emotional role function.

Opiate Signalling in the Ovary

Beata Seeber

Prompted by our clinical work on the central nervous system effects of opiate antagonists on ovulatory disorders, we focused on studying the effects of opiates in the periphery. Specifically, we were able to demonstrate for the first time the presence of opiate receptors on human granulosa cells. Further, we have reported results from stimulation experiments using opiate agonists and antagonists *in vitro* on the functioning of human granulosa cell lines as well as primary granulosa cells. Future experiments are focusing on specific subtypes of opiate receptors in the ovary and in

evaluating their role in other conditions associated with anovulation, especially oocyte aging. Opiate signalling during the oocyte maturation process is also being studied further.

Recurrent Miscarriage

Bettina Toth, Beata Seeber,

Susanne Hofer-Tollinger

Recurrent miscarriage affects 2-5% of women during childbearing years. Although several risk factors including anatomical, endocrine, genetic and other risk factors are established, the aetiology in nearly 50% of cases remains unknown. Therefore the identification of new risk factors as well as potential new treatment strategies is part of our ongoing research.

Medical Management of Early Pregnancy Failure

Bettina Toth, Beata Seeber

Early pregnancy failure (EPF) (e.g. missed abortion) has traditionally been managed by surgical curettage and evacuation of the uterus. This is an operative procedure that is associated with potential surgical risks and with adverse effects on the function of the endometrium with respect to future pregnancies. In cooperation with the Department of Obstetrics and Gynaecology, we have optimized the medical management of EPF and offer it as a first-line management option to women. We have undertaken several projects to look critically at the outcomes and success rates. We have achieved an over 90% success rate with this method with a high safety and tolerability, with very few women needing additional medical or operative interventions. In addition, through a survey of patients, we have received very positive feedback about the acceptability of the treatment, which the women strongly prefer to surgery. In cooperation with Prof. Courtney Schreiber of the University of Pennsylvania, we are focusing on predictive markers in cases of treatment failure, to better be able to counsel our patients.

Tolerance, Early Implantation Failure

Susanne Hofer-Tollinger, Bettina Toth

Tolerance is the accepted hypothesis for the immunological paradox of maintaining a pregnancy. Despite the antigenic dissimilarity between mother and embryo, the embryo is not rejected. Previous studies have proposed that a break-down of tolerance may induce pathological conditions associated with miscarriage or preeclampsia. Since immune dysfunction may contribute to implantation failure through negative effects on the foeto-maternal interphase, we

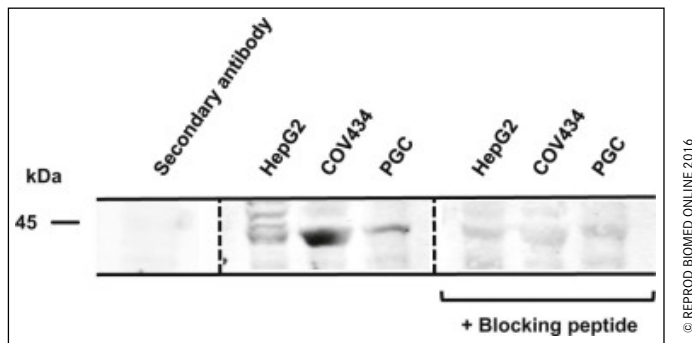

© REPROD BIOMED ONLINE 2016

Fig. 2: First report of the detection of opiate receptors OPRM1 by Western Blot in a human granulosa cell line (COV434) and in whole cell lysates of primary granulosa cells (PGC). HepG2 cells served as a positive control. In the presence of the immunizing peptide, the detected signal is absent.

aimed to study in vitro the role of dendritic cells (DCs) in human reproduction, focusing on their function and gene expression. DCs not only initiate the immune response but also induce tolerance. We have already identified promising candidates which are now being studied in more detail. We aim to further elucidate the immunological events surrounding implantation, especially to clarify the role of DC. The potential clinical applications might be the establishment of a test for embryo selection. With this work we hope to make a valuable contribution to the understanding of foetal tolerance and in the long run help to establish immune suppressive strategies and treatment options especially for patients with implantation failure. This research project is conducted in close collaboration with the Dept. of Dermatology (Ch. Heufler).

Fertility Preservation

Katharina Winkler-Crepaz, Susanne Hofer-Tollinger, Bettina Böttcher

Cancer affects many women of reproductive age who wish to preserve their fertility. An undesirable consequence of many of the commonly used chemotherapies as well as pelvic irradiation is their deleterious effect on the gonads. This can lead to premature ovarian failure, symptoms of menopause, infertility and childlessness. Other disease processes such as ovarian tumours, chromosomal disorders such as Turner Mosaic or fragile X Premutation can likewise lead to a premature loss of ovarian function and fertility.

One possible strategy to preserve female fertility is the cryopreservation of ovarian tissue prior to the gonadotoxic treatment. Once the patient is cured, ovarian function can be restored by autotransplantation of the tissue. The Department of

Gynaecological Endocrinology and Reproductive Medicine was the first centre to perform ovarian tissue cryopreservation in Austria. Oncologic patients from all over Austria, South Tyrol and Southern Germany have been referred to Innsbruck. In order to improve the success rates of cryopreservation and transplantation, we have used xenotransplantation as an approach to as-

sess the quality of ovarian tissue prior to transplantation as well as to investigate the mechanisms of follicular development after transplantation.

The fertility preservation unit of our clinic is interested in studying follicular growth and functionality. Hereby we are focused on the molecular mechanisms involved in the initiation of follicular growth and follicular loss. For this purpose, we conducted a xenotransplantation study to analyse the effects of transplantation on human ovarian tissue. By means of immunohistochemistry, TUNEL staining and qPCR we could show that following xenotransplantation, follicles initiated growth while Phosphatase and Tensin Homolog Deleted on Chromosome 10 (PTEN) gene expression was down-regulated. Thus, the higher proportion of growing follicles compared to resting follicles observed after xenotransplantation is most likely due to down-regulation of PTEN gene expression followed by acceleration of follicular recruitment.

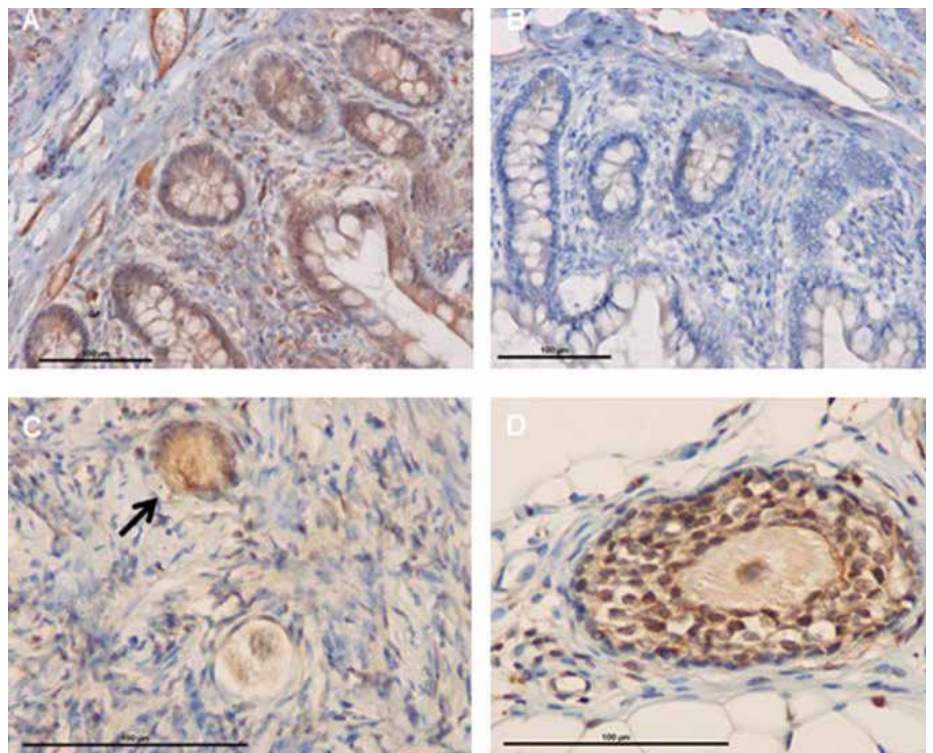

© J ASSIST REPROD GENET 2016

Fig. 3: Immunohistochemical visualization of PTEN. A) PTEN IHC positive control staining of human colon tissue. PTEN positive cells are indicated by brown staining; B) PTEN IHC negative control of human colon tissue; C) PTEN positive primary follicle (arrow) was indicated by brown staining of granulosa cells as well as staining of nuclei and cytoplasm of an oocyte; a primordial follicle shown in the picture is PTEN negative D) PTEN positive secondary follicle.

Transgender and Gender-Nonconforming Individuals

Katharina Winkler-Crepaz, Bettina Böttcher
Transgender individuals experience discord between their biological sex and their self-identified gender and seek to develop the physical characteristics of the desired gender. The Department provides cross-sex hormone therapy for adolescents as well as adults, both in cases of female to male (FtM) and male to female (MtF) treatment. We are currently investigating the effect of visual erotic stimuli on the activity of specific brain regions in FtM transgender patients via functional MRT in collaboration with the Department of Neuroradiology.

Industry-Sponsored Studies

Verena Porto

ESPARIOS - the aim of the study was to evaluate the safety and efficacy of different dose combinations of an aromatase inhibitor and a progestin intravaginal ring versus placebo and leuprorelin/leuprolide acetate in women with symptomatic endometriosis. Secondary objectives were the sustainability of treatment effect and recurrence of symptoms.

ASTEROID 2 - the aim of this study was to assess the efficacy and safety of vilaprisan (a novel progesterone receptor modulator -PRM-) in patients with uterine fibroids a randomized, placebo- and active comparator-controlled study to assess the efficacy and safety of vilaprisan in patients with uterine fibroids. The primary measure of efficacy was the amenorrhoea rate; secondary measures included time to normalized menstrual bleeding and percentage change in UF volume.

MK8342B-062 - the aim of this study was to compare the contraceptive efficacy and safety of the MK-8342B (Etonogestrel + 17 β -Estradiol) Vaginal Ring in comparison to the Levonorgestrel-Ethinyl Estradiol (LNG-EE) 150/30 μ g Combined Oral Contraceptive (COC) in Healthy Women 18 Years of Age and Older, at Risk for Pregnancy. This was a Phase 3, Randomized, Active-Comparator Controlled Clinical Trial

Selected Publications

Follicular growth after xenotransplantation of cryopreserved/thawed human ovarian tissue in SCID mice: dynamics and molecular aspects

Ayuandari, Sarrah, Winkler-Crepaz, Katharina, Paulitsch, Monika, Wagner, Cora, Zavadil, Claudia, Manzl, Claudia, Ziehr, Stephanie C., Wildt, Ludwig, Hofer-Tollinger, Susanne, JOURNAL OF ASSISTED REPRODUCTION AND GENETICS: 2016; 33: S. 1585-1593

Localization of TrkB and p75 receptors in peritoneal and deep infiltrating endometriosis: an immunohistochemical study

Dewanto, Agung, Dudas, Jozsef, Glueckert, Rudolf, Mechsner, Sylvia, Schrott-Fischer, Anneliese, Wildt, Ludwig, Seeber, Beata, REPRODUCTIVE BIOLOGY AND ENDOCRINOLOGY: 2016; 14: S. 43

Opiate receptor blockade on human granulosa cells inhibits VEGF release

Lunger, Fabian, Vehmas, Anni P, Fuernrohr, Barbara G., Sopper, Sieghart, Wildt, Ludwig, Seeber, Beata, REPRODUCTIVE BIOMEDICINE ONLINE: 2016; 32: S. 316-322

The TRUFFLE study; fetal monitoring indications for delivery in 310 IUGR infants with 2 year's outcome delivered before 32 weeks of gestation.

Visser, GH., Bilardo, CM., Derks, JB., Ferrazzi, E., Fratelli, N., Frusca, T., Ganzevoort, W., Lees, C., Napolitano, R., Todros, T., Wolf, H., Hecher, K., Marlow, N., Arabin, B., Brezinka, C., Diemert, A., Duvkot, JJ., Martinelli, P., Ostermayer, E., Papageorghiou, AT., Schlembach, D., Schneider, K., Thilaganathan, B., Valcamonica, A., ULTRASOUND IN OBSTETRICS & GYNECOLOGY: 2016; [Epub ahead of print]: S.

Impact of endometriosis on quality of life, anxiety, and depression: an Austrian perspective

Friedl, F, Riedl, D., Fessler, S., Wildt, L., Walter, M., Richter, R., Schuessler, G., Boettcher, B., ARCHIVES OF GYNECOLOGY AND OBSTETRICS: 2015; 292: S. 1393-1399

Selected Funding

Diverse industry-sponsored and academic projects

Collaborations

- Prof. Dr. Udo Markert, Plazentalabor Jena, Germany
- Dr. Rienk Nieuwland, AMC Amsterdam, the Netherlands
- Prof. Courtney Schreiber, University of Pennsylvania, USA

Devices & Services

- Ovarian tissue cryobank
- CL-863 Freeze Control, Cryologic (automated freezer)
- Tecan Reader, Genius Pro, Fluorescence/Luminescence/Absorbance Reader

Otorhinology



Director:
Univ.-Prof. Dr. Herbert Riechelmann

Contact:
Anichstraße 35
6020 Innsbruck

Herbert.Riechelmann@i-med.ac.at
Phone: +43 512 504 23141
Fax: +43 512 504 23144
http://hno.tirol-kliniken.at

Research Branch (ÖSTAT Classification)

302023, 302027, 302029, 302055

Keywords

Head and neck neoplasm, HPV, inner ear morphology, accuracy of computer aided surgery

Research Focus

- Error analyses for computer assisted surgery
- Targeted therapy for head and neck squamous cell carcinoma
- Ion channel and nerve regeneration inner ear

General Facts

The major aim of the Department of Otorhinology is to provide independent basic and clinical research in the field of Otorhinology to optimize patient treatment. The basic research is provided by three independent laboratories: 1) the Molecular Biology and Oncology Laboratory by PD Dr. Jozsef Dudas; 2) the 4D Visualization Laboratory by Univ.-Prof. Dr. Wolfgang Freysinger; 3) the Inner ear Laboratory by Univ.-Prof. Dr. Annelies Schrott-Fischer. These three major research units are in close cooperation with the clinician scientists enabling translational research projects with clinical impact in three major focuses of Otorhinology. Furthermore the Department is in close cooperation with local industry, developing for instance a laryngeal pacemaker or a vestibular implant.

Further clinical research focuses on clinical oncology, rhinopathy and clinical aspects of hearing implants.

Research

Molecular Biology and Oncology Laboratory

PD Dr. Jozsef Dudas

Tumor-associated fibroblast-conditioned medium induces CDDP resistance in HNSCC cells

Objective: the epithelial-mesenchymal transition (EMT) contributes to tumour progression and metastasis. We aimed to investigate the effects of EMT on Cisplatin resistance in HNSCC (head and neck squamous cell carcinoma)-cells.

Methods: EMT was induced in HNSCC cells using conditioned medium from a tumour cell/fibroblast co culture and confirmed with vimentin and E cadherin expression analysis at RNA and protein level. The tumour cells were alternatively treated with 1 ng/ml TGFβ1. The response to Cisplatin was evaluated with viability and clonogenic assays.

Results: Treatment with conditioned medium induced a mesenchymal phenotype and increased the viability of the tumour cells. Moreover, it doubled the IC50 of Cisplatin of SCC-25 cells from 6.2 μM to 13.1 μM (p<0.001). The IC50 of Cisplatin of Detroit 562 cells was increased following treatment with conditioned medium from 13.1 μM to 26.8 μM (p<0.01). Treatment with TGF1 induced similar phenotypic changes as co-culture conditioned medium, but decreased tumor cell viability and did not alter

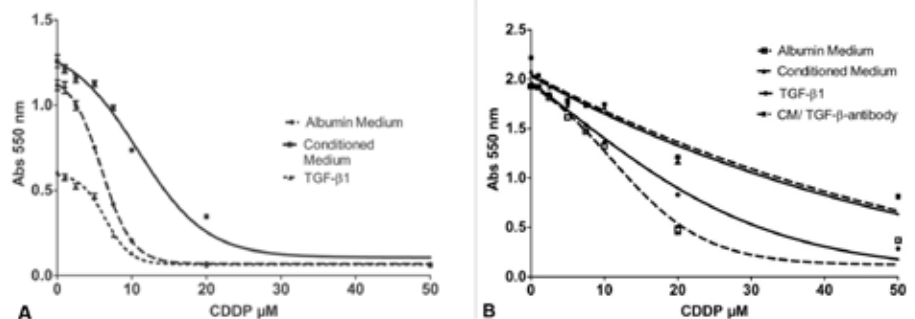

© Oncotarget, 2016

Fig. 1: Cell viability of SCC-25 cells (A) or Detroit 562 cells (B) exposed to increasing doses of CDDP (0- 50 μM) following treatment with albumin-containing medium (control; dotted line with spheres), co-culture conditioned medium (solid line with black squares), medium supplemented with TGFβ1 1 ng/ml (dotted line with triangles) and co-culture conditioned medium plus anti TGFβ antibody (1.5 μg/ml) (solid line with white squares). Four parameter nonlinear logistic regression model, whiskers indicate standard error of the mean (SEM).

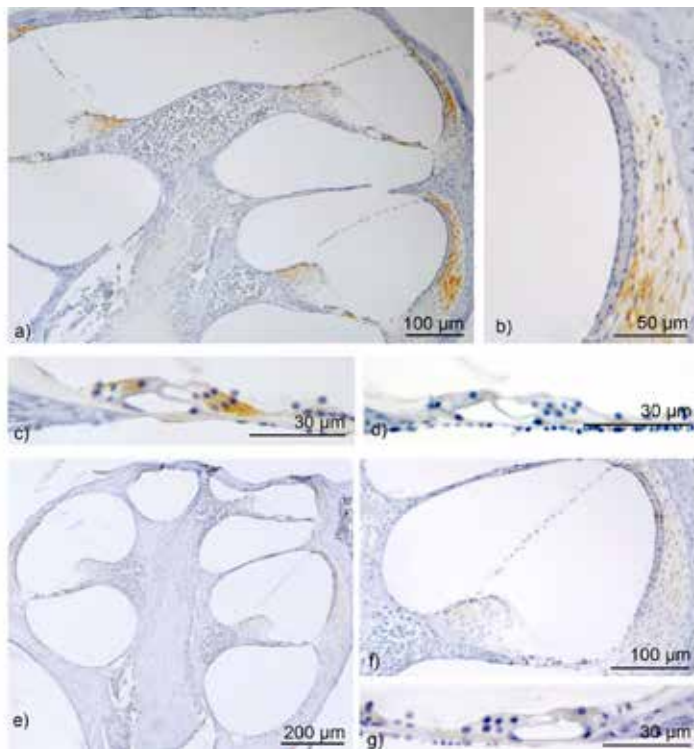

Fig. 2: Sepsis mice with a high hearing loss showed positive CC-3 cells mainly in the lateral wall and in the organ of Corti (a,c). In the lateral wall, positive immunostaining was observed in type I and type V fibrocytes (a). In the organ of Corti the Deiters' cells and inner hair cells were strongly stained, while no reactivity was found in the cell body of the outer hair cells (c). In sepsis mice with a low hearing loss altogether fewer cells were stained and immunoreactivity intensity was lower. (b,d) In the sham mice only a faint staining of some fibrocytes of the spiral ligament was found (e-g).

Cisplatin resistance (Figure).

Conclusion: Cell free medium from an epithelial tumour cell/fibroblast co-culture was able to induce EMT in HNSCC cells. Co-culture treated HNSCC cells revealed increased viability and were less sensitive to Cisplatin treatment. TGF β 1 also induced a mesenchymal phenotype, but decreased tumour cell viability and did not alter resistance to CDDP in HNSCC cells.

Inner Ear Biology

Univ.-Prof. Dr. Annelies Schrott-Fischer

Neurosensory differentiation and innervation patterning in the human foetal vestibular end organs between the gestational weeks 8-12

Balance orientation depends on the precise operation of the vestibular end organs and the vestibular ganglion neurons. Previous research on the assemblage of the neuronal network in the developing foetal vestibular organ has been limited to data from animal models. Insights into the molecular expression profiles and signalling moieties involved in embryological development of

the human foetal inner ear have been limited. We present an investigation of the cells of the vestibular end organs with specific focus on the hair cell differentiation and innervation pattern using an uninterrupted series of unique specimens from gestational weeks 8 to 12.

Nerve fibres positive for peripherin innervate the entire foetal crista and utricle, whereas in rodents only the peripheral regions of the cristae and the extra-striolar region of the statolithic organs are stained. At week nine, transcription factors PAX2 and PAX8 were observed in the hair cells whereas PAX6 was observed for the first time among the supporting cells of the cristae and the satellite glial cells of the vestibular ganglia. Glutamine synthetase, a regulator of the neurotransmitter glutamate, is strongly expressed among satellite glia cells, transitional zones of the utricle and supporting cells in the sensory epithelium. At gestational week 11, electron microscopic examination reveals bouton contacts at hair cells and first signs of the formation of a protocalyx at type I hair cells.

Our study provides first-hand insight into the foetal development of the vestibular end organs as well as their pattern of innervation by means of immunohistochemical and EM techniques, with the aim of contributing towards our understanding of balance development.

4D Visualization Laboratory

Univ.-Prof. Dr. Wolfgang Freysinger

Estimating FLEimage distributions of manual fiducial localization in CT images

Purpose: The fiducial localization error distribution (FLE) and fiducial configuration govern the application accuracy of point-based registration and drive target registration error (TRE) prediction models. The error of physically localizing patient fiducials (FLEpatient) is negligible when a registration probe matches the implanted screws with mechanical precision. Reliable trackers provide an unbiased estimate of the positional error (FLEtracker) with cheap repetitions. FLE further contains the localization error in the imaging data (FLEimage), sampling of which in general is expensive and possibly biased. Finding the best techniques for estimating FLEimage is crucial for the applicability of the TRE prediction methods.

Methods: We built a ground-truth (gt)-based unbiased estimator (FLEgt) of FLEimage from the samples collected in a virtual CT dataset in which the true locations of image fiducials are known by definition. Replacing true locations in FLEgt by the sample mean creates a practical difference-to-mean (dtm)-based estimator (FLEdtm) that is applicable to any dataset. To check the practical validity of the dtm estimator, ten persons manually localized nine fiducials ten times in the virtual CT and the resulting FLEdtm and FLEgt distributions were tested for statistical equality with a kernel-based two-sample test using the maximum mean discrepancy (MMD) (Gretton in J Mach Learn Res 13:723-773, 2012) statistics at $\alpha = 0.05$.

Results: FLEdtm and FLEgt were found (for most of the cases) not to be statistically significantly different; conditioning them on persons and/or screws however yielded statistically significant differences much more often.

Conclusions: We conclude that FLEdtm is the best candidate (within our model) for estimating FLEimage in homogeneous TRE prediction models. The presented approach also allows ground-truth-based numerical validation of FLEimage estimators and (manual/automatic) image fiducial localiza-

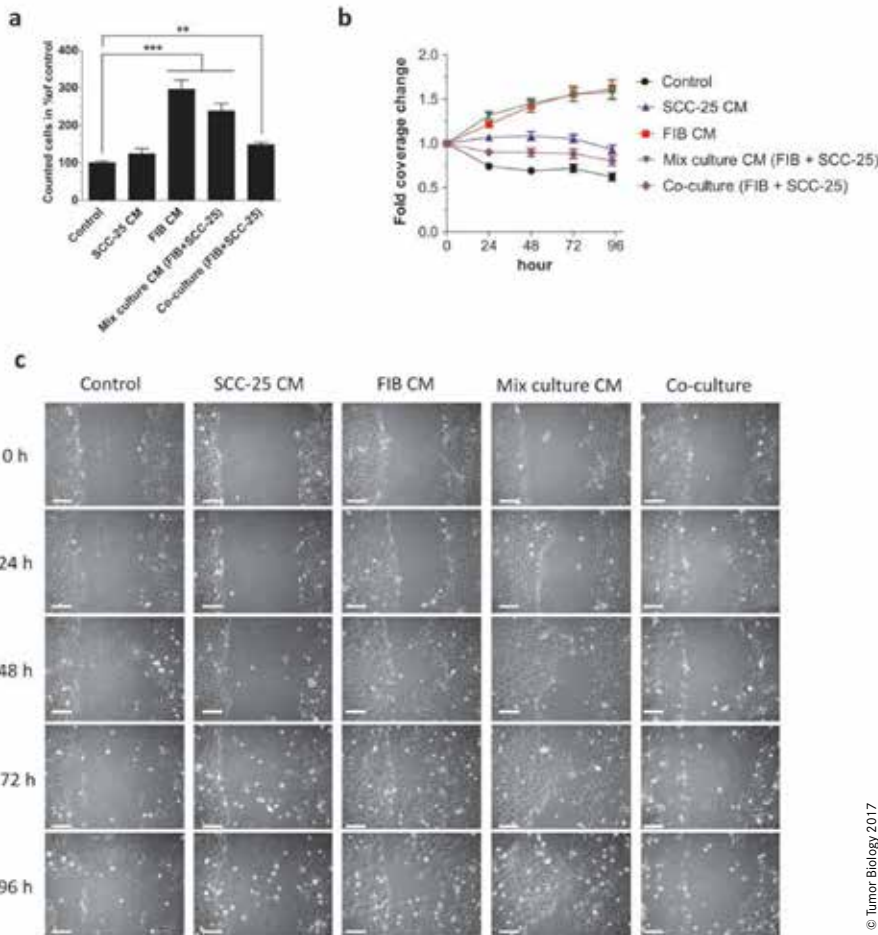

Fig. 3: Proliferation, viability and migration of conditioned medium treated or co-cultured SCC-25 cells. After three days of treatment SCC-25 cells were counted and cell migration was investigated using a scratch assay. (a) The treatment of SCC-25 cells with fibroblasts (FIB) and mix culture conditioned medium (CM) ($p < 0.001$) and co-culture ($p < 0.01$) lead to significantly higher cell numbers compared to control (albumin-medium treated cells, which was set to 100%). (b) FIB CM and mix culture CM significantly ($p < 0.001$) increased the lateral migration of SCC-25 cells even in the first 24 hours. SCC-25 cells treated with SCC-25 CM or co-cultured with FIBs exhibited a significant higher cell coverage than albumin-medium-treated (control) cells (SCC-25 CM: $p < 0.001$, co-culture: $p < 0.01$). (c) These effects could also be observed in the images taken every 24 hours, where SCC-25 cells migrated towards empty space when treated with FIB CM or mix culture CM. CM, conditioned medium; FIB, Human gingival fibroblasts; $P < 0.01$: **; $P < 0.001$: ***. Cells treated with FIB CM, or mix culture CM, or co-cultured SCC-25 cells showed elongated, mesenchymal-like morphology, especially in the scratched area. Bars: 100 μm .

tion methods in phantoms with parameters similar to clinical datasets.

Clinical Research

Dr. Volker Scharfinger

Implementation of a clinical cancer register at the department of otorhinolaryngology

A clinical cancer register is an important tool for research and quality control. Increasing numbers of data cannot be admin-

istrated by simple tables. So, cancer registries need extensive concepts to provide high levels of validity, completeness, comparability and timeliness. They need a data structure which allows simultaneous multi-user access and high quality data analysis. Standardized data input should lead to comparable results over the years and external data should be integrated easily. In 2015 a clinical cancer register was implemented at the Department of Otorhi-

nolaryngology of the Medical University of Innsbruck. A relational database model in Microsoft Access was used for several reasons. As a first step all existing tables were included into the database. Furthermore queries for data from external databases were established, so that they can be included in periodic intervals. Multi-step procedures have been developed to convert this data to valid and complete variables. Incomplete data are automatically marked for manual editing. By this strategy it was possible to include the results of the weekly tumour board sessions into the database. This is very important, because essential changes in the history of a patient are usually stated in these board meetings. A user friendly surface was generated, so that even staff members unexperienced with Access could easily be trained to use this database. In the start-up period the database was frequently re-evaluated by several staff members.

So far more than 900 patients are successfully administered by the database. Data for retrospective analysis and studies could be easily exported to other file formats and statistically analysed. Number of cases for prospective studies could easily be estimated upon the available information.

The implemented clinical cancer register at our department is very effective to get information about cancer patients for clinic, research and quality control.

Sensitivity of Tumour Surface Brushings to detect Human Papilloma Virus DNA in Head and Neck Cancer

Dr. Barbara Kofler

Objective: Human papilloma virus (HPV) induced head and neck squamous cell carcinoma (HNSCC) represents a distinct tumour subset. We questioned how accurately a brushing from the tumour surface detects HPV in patients with HNSCC.

Materials and methods: Brushings from the tumour surface were compared with HPV DNA isolation from formalin-fixed and paraffin-embedded (FFPE) tumour biopsies, which served as the reference standard. In both matrices, HPV DNA was detected using a commercially available test kit. In addition, p16 was assessed in tumour biopsies by immunohistochemistry (IHC). The tumors were considered p16 positive if 70% or more of cancer cells expressed p16.

Results: 93 patients with HNSCC were included. Sensitivity and specificity of the brush test were 83% (95% CI: 67-92%) and 85% (95%CI: 72-93%). Results of p16 IHC were concordant with FFPE samples DNA

© Tumor Biology 2017

determinations in 73/93 patients. In 53 patients (57%) the tumour was located in the oropharynx and in 40 patients (43%) the tumour was located in the non-oropharynx region. Sensitivity and specificity of the brush test in patients with oropharyngeal cancer was higher with 86% (95%CI: 70–95%) and 89% (95%CI: 65–99%).

Conclusion: Superficial brushes from the tumour surface may be used to identify HPV positive HNSCC.

Selected Publications

Tumor-associated fibroblast-conditioned medium induces CDDP resistance in HNSCC cells

Steinbichler, Teresa Bernadette, Metzler, Veronika, Pritz, Christian, Riechelmann, Herbert, Dudas, Jozsef, ONCOTARGET: 2016; 7: S. 2508-2518

Neurosensory Differentiation and Innervation Patterning in the Human Fetal Vestibular End Organs between the Gestational Weeks 8-12

Johnson Chacko, Lejo, Pechriggl, Elisabeth J., Fritsch, Helga, Rask-Andersen, Helge, Blumer, Michael J. F., Schrott-Fischer, Anneliese, Glueckert, Rudolf, FRONTIERS IN NEUROANATOMY: 2016; 10: S. 111

Laryngeal pacing via an implantable stimulator for the rehabilitation of subjects suffering from bilateral vocal fold paralysis: A prospective first-in-human study

Mueller, Andreas H., Hagen, Rudolf, Foerster, Gerhard, Grossmann, Wilma, Baumbusch, Katrin, Pototschnig, Claus, LARYNGOSCOPE: 2016; 126: S. 1810-1816

Severe malaria in children leads to a significant impairment of transitory otoacoustic emissions - a prospective multicenter cohort study (vol 13, pg 125, 2015)

Schmutzhard, Joachim, Lackner, Peter, Helbok, Raimund, Hurth, Helene Verena, Aregger, Fabian Cedric, Muigg, Veronika, Kegele, Josua, Bunk, Sebastian, Oberhammer, Lukas, Fischer, Natalie, Pinggera, Leyla, Otieno, Allan, Ogutu, Bernards, Agbenyega, Tsiri, Ansong, Daniel, Adegnik, Ayola A., Issifou, Saadou, Zorowka, Patrick, Krishna, Sanjeev, Mordmuller, Benjamin, Schmutzhard, Erich, Kremsner, Peter, BMC MEDICINE: 2016; 14: S. 70

Microdebrider-Assisted Intracapsular Tonsillectomy in Adults With Chronic or Recurrent Tonsillitis

Bender, Birte, Blassnigg, Elisabeth Constanze, Bechthold, Jana, Kral, Florian, Riccabona, Ursula, Steinbichler, Teresa, Riechelmann, Herbert, LARYNGOSCOPE: 2015; 125: S. 2284-2290

Selected Funding

- Univ.-Prof. Mag. Dr. Wolfgang Freysinger, Project: navABI FFG 350.000 EUR
- PD Mag. Dr. Rudolf Glueckert, Project: Gapless Mensch:Maschine Interface für das Innenohr FWF 280.000 EUR
- Georgi Diakov, BSc, MSc, PhD, Project: Trifokale Rekonstruktion durch Gesichtsmerkmale zur automatisierten Navigation der HNO-Chirurgie. OeNB 100.000 EUR

Collaborations

- TU München mit Informatik, Prof. Nassir NABAB
- Universität Bern, HNO, Prof. Marco Caversaccio
- Brigham & Womens Hospital, Harvard, Boston, MA, USA, Prof. Ron KIKINIS
- Mechatronik, MCI, Innsbruck, DI Dr. Andres MEHRLE Brainlab, München
- iSYS, Kitzbühel, CEO Dr. Michael VOGELE
- ACMIT, Wr. Neustadt, CEO Dr. Gernot Kronreif
- LSTMH, Liverpool, UK
- Semmelweis University Budapest, Inst. Pathology and Experimental Cancer Research Budapest, Hungary
- Department of Surgical and Molecular Pathology, National Institute of Oncology, Budapest, Hungary
- Department of Otorhinolaryngology, University Lübeck, Germany
- Cochlear Signaling and Tissue Engineering Laboratory, Laboratory Director, USA Josef M. Miller, Ph.D., www.khri.med.umich.edu/research/miller_lab/index.php
- Auditory Anatomy Laboratory, Laboratory Director, USA Richard Altschuler, Ph.D. www.khri.med.umich.edu/research/altschuler_lab/index.php
- Universität Uppsala, Schweden, Helge Rask-Andersen www.medfarm.uu.se
- Department für Anatomie, Histologie und Embryologie, Sektion für Neuroanatomie, MUI, Lars Klimaschewski, Barbara Hausott
- Department für Anatomie, Histologie und Embryologie Sektion für Klinisch-Funktionelle Anatomie, Brenner Erich, Elisabeth Pechriggl
- Department für Anatomie, Histologie und Embryologie, Sektion für Histologie und Embryologie, Kristian Pfaller
- Veterinärmedizinische Universität, VetCore Facility for Research Imaging Unit, Stephan Handschuh
- UMIT Hall Institut für Biomedizinische Informatik, Division für Biomedizinische Bildanalyse, Karl Fritscher, Rainer Schubert
- UMIT Hall, Institut für Elektrotechnik und Biomedizinische Technik, Christian Baumgartner
- MedEl Innsbruck, Ingeborg Hochmair, Carolyn Garnham, Claude Jolly
- Frank Rattay, Computational Neuroscience and Biomedical Engineering, Institute for Analysis and Scientific Computing, Vienna University of Technology, Austria
- University of Tampere, Finland, Ilmari Pyykko
- University of Angers, France, Saulnier Patrick, Guillaume Bastiat
- University of Southampton, UK, Tracey Newman
- The Bionics Institute, East Melbourne, Australia, Andrew K. Wise
- Inserm U 254 Neurobiologie de l'Audition, Montpellier, France, Eybalin Michel

Devices and Services

- TissueFaxes from TissueGnostics

Hearing, Speech and Voice Disorders



Director:
o. Univ.-Prof. Dr. Patrick Zorowka

Contact:
Anichstraße 35
6020 Innsbruck

hss@tirol-kliniken.at
Phone: +43 512 504 23218
Fax: +43 512 504 23217
www.hss-innsbruck.at
www.hoerimplantate-innsbruck.at

Research Branch (ÖSTAT Classification)

103002, 301401, 302023,
302027, 302029

Keywords

Aural effects of noise, hearing disorders, hearing rehabilitation, sound localisation, sound localisation with hearing implants, speech understanding with hearing implants, tinnitus, voice disorders

Research Focus

- Assessing auditory performance (e.g. speech understanding, sound source localisation) of patients with hearing implants or hearing aids.
- Assessing neurocognitive processes associated with first and second language acquisition.
- Developing objective methods for hearing implant fitting in children.
- Analysing the effects of noise on hearing health through epidemiological studies of tinnitus and hearing complaints in adolescents.

General Facts

The Department HSV was founded in 1974, after a "Chair in Audiology and Phoniatics" was established at Innsbruck Medical Faculty in 1968. This was the first chair in these specialties in the German speaking countries. Today, the HSV is Austria's largest institution in the fields of Audiology, Pediatric Audiology and Phoniatics. It offers a full range of clinical services for diagnosis and treatment of disorders of hearing, speech, language, swallowing and of childhood learning problems.

Research facilities of the HSV include the *Lab for Psycho-Acoustics* and the *Lab for Cognitive Neuroscience*. In the latter neuronal processing mechanisms underlying language acquisition in children are investigated by electroencephalography (EEG), functional near-infrared spectroscopy (fNIRS) and magnetic resonance imaging (MRI). In the Lab for Psycho-Acoustics, which is equipped with an anechoic chamber for high-precision acoustic measurements, human hearing functions are tested under very specific conditions, including the use of hearing implants.

Since the 1990s, the Department has been significantly involved in implementing Universal Newborn Hearing Screening in Austria. In addition, the Department enjoys an excellent reputation as a centre for

high-standard audio processor fitting in patients with hearing implants.

Research

Stapedius Reflex in Cochlear Implant (CI) Patients

Kurt Stephan

The postoperative measurement of the Stapedius reflex elicited via CI is a well-established objective method for fitting cochlear implants in children. Thereby, the electrical reflex threshold (ESRT) is determined through impedance audiometry, and the results are used for setting the level of maximum stimulation intensity in the fitting of the CI speech processor. Efficient application of this method requires a normal functioning middle ear – a condition not always present in young children. A further limiting factor for its routine application is the lack of easy to use and optimized instrumentation.

In order to overcome these restraints of ESRT testing, a computerized testing system was developed at the HSV. The system provides simultaneous impedance monitoring of the Stapedius reflex in real time during electrical stimulation via CI with minimum effort for the investigator. The clinical usability of the testing procedure (which may be extended to CI fitting in elderly and multiple handicapped patients)



Fig. 1: A baby is being prepared for participation in a study revealing her brain activities related to specific language cues.

was evaluated. It was found that ESRT testing can be successfully applied in 66% of the children. This percentage can be raised to about 85% if the children with middle ear problems are administered detumescent nose drops. In addition to these findings, the evaluation of the long-term stability of ESRT is an ongoing research question of this project.

Sound Localization in Single-Sided Deaf Cochlear Implant Patients

Josef Seebacher

Sound source localization (SSL) was studied in patients with single-sided deafness supplied with cochlear implants (CI). Localization tests performed in an anechoic chamber showed that the strategies of SSL in these patients differ considerably from those of normal hearing individuals. They make use rather of interaural level differences than of interaural time differences to localize where the sound comes from. Interaural level differences occur due to the head shadow effect, which is effective at frequencies above 1.5 kHz. Exactly in this frequency range the cochlea implant transmits its signal faster to the hearing nerve than does a normal functioning inner ear. In a second experiment an attempt was made to compensate this time lag by delaying the signal of the cochlear implant. Results confirmed the hypothesis that a delay on the cochlear implant side has an impact on the patients' SSL abilities. The SSL performance was best when the delay was in the range of 1–2 ms, which corresponds to electrophysiologically measured latency differences in patients with CI. These results motivate further investigations in patients with bimodal supply (i.e. with a CI on one side and a hearing aid on the other) where even larger time differences are observed.

Factors influencing Quality of Life in CI Patients

Viktor Weichbold

This project is part of an extensive project investigating the factors influencing the outcome after cochlear or middle ear implantation in hearing impaired persons. Previous studies showed that cochlear implantation improves the quality of life in these patients, but the degree of improvement varies considerably between patients. In consequence, attention has been directed to identifying the factors that account for the variation. It is hoped that, by considering these factors in patient selection, patient counselling and provision of clinical services, the outcome after

hearing implantation can be still improved.

Identifying Early Neuronal Markers in Infants with a Familial Risk for Dyslexia

Sonja Rossi

Developmental dyslexia is a disorder affecting reading and writing abilities in school-aged children. The present project aims at identifying early neuronal markers in infants below 2 years of age, thus prior to a possible manifestation of dyslexia. By applying simultaneously two neuroscientific methods, the electroencephalography (EEG) and the functional near-infrared spectroscopy (fNIRS) we investigate the differentiation of linguistic rules of the native language compared to rules of a foreign language in order to identify early neuronal abnormalities. Familial risk for dyslexia is classified by either a parent or older siblings suffering from developmental dyslexia. Neuronal markers in the focus of investigation are an atypical brain lateralization and an absent or delayed discrimination ability.

Electrophysiological and Optical Correlates of Inner Speech in Children and Adults

Sonja Rossi, Franziska Stephan

Adults are able to use inner speech when they think. This is a complex executive function involving several aspects such as cognitive control, inhibition, and attention. If the task gets more difficult using overt speech increases. Children have to develop this ability. However, it is not clear at which age children start using inner speech like adults. Thus, we study the impact of executive functions on speech by simultaneously assessing the electroencephalography (EEG) and the functional near-infrared spectroscopy (fNIRS). 6–7-year-olds, 8–9-year-olds, and adults will be assessed while they see pictures of real objects they have to name either overtly or covertly. Stronger inhibitory effects associated with elevated prefrontal activity as well as increased amplitudes of event-related brain potentials (ERPs) are expected when planning inner speech in contrast to overt speech.

Syntactic Processing in Children and Adults

Sonja Rossi

Processing irregular verbs is a quite difficult task, especially for children. With the present project we aim at investigating whether electrophysiological correlates can provide differential processing mechanisms at a neuronal level, possibly not yet present

at a behavioral level. Children aged 6–7 and 8–9 years as well as adults as a control group listen to morphosyntactically correct or incorrect sentences while the electroencephalography (EEG) is recorded. Different amplitudes are expected with respect to the P600 component (i.e., an event-related brain potential component reflecting the difficulty of syntactic integration).

Selected Publications

A New Transcutaneous Bone Conduction Hearing Implant: Short-term Safety and Efficacy in Children
Baumgartner, Wolf-Dieter, Hamzavi, Jafar-Sasan, Boenheim, Klaus, Wolf-Magele, Astrid, Schloegel, Max, Rischelmann, Herbert, Zorowka, Patrick, Koci, Viktor, Keck, Tilman, Potzinger, Peter, Sprinzl, Georg,
OTOLOGY & NEUROLOGY: 2016; 37: S. 713-720

Age of onset of Recurrent Respiratory Papillomatosis: a distribution analysis
San Giorgi, M., van den Heuvel, ER., Tjon Pian Gi, RE., Brunings, JW., Chirila, M., Friedrich, G., Golusinski, W., Graupp, M., Horcasitas Pous, RA., Ilmarinen, T., Jackowska, J., Koelme, JC., Ferran Vila, F., Weichbold, V., Wierzbicka, M., Dikkers, FG.,
CLINICAL OTOLARYNGOLOGY: 2016; 41: S. 448-453

Bilateral use of active middle ear implants: speech discrimination results in noise
Wolf-Magele, Astrid, Koci, Viktor, Schnabl, Johannes, Zorowka, Patrick, Rischelmann, Herbert, Sprinzl, Georg Mathias,
EUROPEAN ARCHIVES OF OTO-RHINO-LARYNGOLOGY: 2016; 273: S. 2065-2072

Improvement of sound source localization abilities in patients bilaterally supplied with active middle ear implants
Koci, Viktor, Seebacher, Josef, Weichbold, Viktor, Zorowka, Patrick, Wolf-Magele, Astrid, Sprinzl, Georg, Stephan, Kurt,
ACTA OTO-LARYNGOLOGICA: 2016; 136: S. 692-698

Universal and language-specific sublexical cues in speech perception: a novel electroencephalography-lesion approach
Obrig, Hellmuth, Mentzel, Julia, Rossi, Sonja,
BRAIN: 2016; 139: S. 1800-1816

Impact of associative word learning on phonotactic processing in 6-month-old infants: A combined EEG and fNIRS study.
Obrig, Hellmuth, Mock, Julia, Stephan, Franziska, Richter, Maria, Vignotto, Nicol, Rossi, Sonja,
DEVELOPMENTAL COGNITIVE NEUROSCIENCE: 2016; [Epub ahead of print]: S.

Electrically evoked compound action potentials are different depending on the site of cochlear stimulation.
van de Heyning, P., Arauz, SL., Atlas, M., Baumgartner, WD., Caversaccio, M., Chester-Browne, R., Estienne, P., Gavilan, J., Godey, B., Gstöttner, W., Han, D., Hagen, R., Kompis, M., Kuzovkov, V., Lassaletta, L., Lefevre, F., Li, Y., Müller, J., Parnes, L., Kleine Punte, A., Raine, C., Rajan, G., Rivas, A., Rivas, JA., Royle, N., Sprinzl, G., Stephan, K., Walkowiak, A., Yanov, Y., Zimmermann, K., Zorowka, P., Skarzynski, H.,
COCHLEAR IMPLANTS INTERNATIONAL: 2016; 17: S. 251-262

Collaborations

- Charité University Medicine, Berlin, Germany
- Clinic for Cognitive Neurology, University Hospital, Leipzig, Germany
- Saxonian Cochlear Implant Center, Technical University of Dresden, Germany
- Department of Linguistics, University of Leipzig, Germany
- Department of Subject Education, Leopold-Franzens University Innsbruck, Austria
- Faculty of Education, University of Leipzig, Germany
- Institute of Sport Science, Leopold Franzens University Innsbruck, Austria
- Max Planck Institute for Human Cognitive and Brain Sciences, Leipzig, Germany
- MED-EL, Innsbruck, Austria
- Scott Sports SA, Givisiez, Switzerland

Devices and Services

- Medical outpatient unit
- Audiology unit
- Pediatric Audiology unit
- Logopedic unit
- Psychology unit
- Lab for Psycho-Acoustics
- Lab for Cognitive Neuroscience

Diagnostic and Interventional Radiology



Director:
o. Univ.-Prof. Dr. Werner Jaschke

Contact:
Anichstraße 35
6020 Innsbruck

radiologie@i-med.ac.at
Phone: +43 512 504 22761
Fax: +43 512 504 22758
<http://radiologie.tirol-kliniken.at>

Research Branch (ÖSTAT Classification)

302010, 302043, 302070,
302071, 302075

Keywords

Radiology, interventional radiology, MRI, CT, angiography, contrast media, ultrasound, PET-CT, robotics, interventional oncology, radiation protection, digital imaging, PACS, microCT

Research Focus

- Ultrasound (elastography, musculoskeletal ultrasound, ultrasound of peripheral nerves, ultrasound guided interventions)
- Multiparametric imaging of prostate cancer
- MRI (quantification of fat/iron; cardiac MRI; spectroscopy of muscle/myocardium; musculo skeletal MRI including stress MRI of the hip and knee, MR mammography)
- Cardiac CT
- Dual Energy CT
- Emergency Radiology, especially trauma
- Sports injury
- Interventional Radiology (endovascular/ oncology)

- Real time dose monitoring of patients
- Diagnosis and treatment of HCC
- Percutaneous stereotactic RFA
- Digital imaging/PACS/post processing of imaging data
- Clinical trials in oncology

General Facts

For clinical research, the Department is equipped with state of the art imaging equipment including 7 CT scanners (1 Dual source/three 64 row/one 32 row/two 16 row), 3 MRI scanners (3T and 1.5T), 1 PET-CT (in cooperation with the Department of Nuclear Medicine), 3 angio suites (1 biplane) and 15 high end ultrasound systems. One CT with a sliding gantry operating in an OR and an imaging suite is dedicated to stereotaxy and CT guided procedures. The Department operates completely digitally using a comprehensive imaging archive that was installed in the year 1999. There are 66 staff members including 30 residents (radiologists in training).

The Section of Experimental Radiology is staffed with 6 physicists with different areas of interest such as MRI, MRS, image data processing, radiation protection and computer applications.

The Department houses research facilities for animals (Small Animals Research Lab). High resolution RF coils for MR imaging of animals are available as well as access to PET imaging. Large animals can be imaged on 1 of the clinical CT scanners (32 rows/Siemens). The Core Facility MicroCT is equipped with 2 MicroCT scanners (vivaCT40/Scanco Medical and XtremeCT II/Scanco Medical) which are operated in cooperation with the Department of Trauma Surgery. Both microCT scanners can be

used for the high resolution imaging of small animals (ranging from mice to rabbits). The XtremeCTII is also used for high resolution scanning of extremities of patients, mostly for the evaluation of bone density (Osteoporosis). Our research projects are mostly clinically orientated. We focus on the rapid translation of research results into clinical practice. Also, most research projects are interdisciplinary. The Department of Radiology and the Department of Neuroradiology have a close cooperation regarding training, patient care and research.

Research

Atherosclerotic Burden and its Relevance in Case of Different Diseases and Treatment Strategies.

Bernhard Glodny, Johannes Petersen
Cardiovascular and cerebrovascular sequelae of atherosclerotic disease are one of the leading causes of morbidity and mortality in humans, and concerns many different fields of medicine. Atherosclerosis can be detected using different modalities of diagnostic imaging. Moreover, treatments are planned using clinical imaging, and cardiovascular risk profiles can be compiled individually. Computed tomography can be used to quantify the “atherosclerotic burden” of all vascular territories in an objective and reproducible manner. Relationships between oral health and health in general have been suspected since many years. One of the first observations to be made in this area of study was that oral and general health is impacted similarly by certain behavioural, social and environmental factors. In the late eighties, and the nineties of the last century, a causal relationship between marginal periodontitis, and atherosclerosis was established.

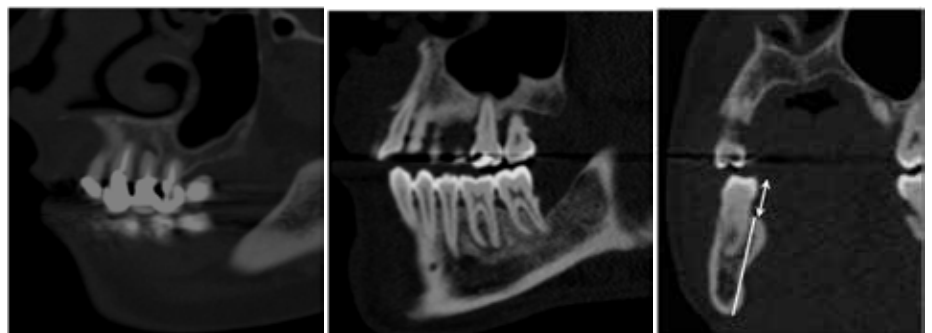

Fig. 1: A typical CAP lesion of a tooth (14) in a semi-coronal reconstruction of a CT. The tooth shows an endodontic filling (a), a CAP lesion of a tooth (46) in a semi-sagittal reconstruction of a CT (b), and a semicoronal reconstruction in the region 46 (c), showing the methods of measurement of the distance between the crown and the alveolar ridge (double arrow) and of measurement of the height of the bone (white line).

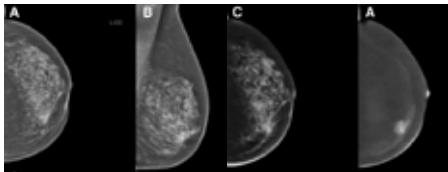

Fig. 2: 65-year-old woman with an invasive ductal carcinoma showing inhomogeneous breast tissue at 9 o'clock as demonstrated by conventional mammography (a, b). Low-energy CESM images (c) are equivalent to conventional mammography, while spectral imaging shows a contrast enhancing mass.

This fitted perfectly with the concept of atherosclerosis as an inflammatory disease. The aim of the present studies is to adopt the theory of atherosclerosis as inflammatory disease in order to ascertain whether caries may be causative for atherosclerosis as well, especially in cases in which the disease has crossed the enamel. Consequent infections of the dental pulp and apical periodontitis may represent additional causes for atherosclerosis. Dental caries (Fig. 1) turned out to be an independent risk factor for a higher atherosclerotic burden of the aorta. Moreover, dental fillings showed an inverse effect, and were found to be an independent protective factor for aortic atherosclerotic burden (Fig. 2). Chronic apical periodontitis also emerged as a risk factor for higher atherosclerotic burden.

Imaging of Breast Cancer

Martin Daniaux, Tobias De Zordo

Example: Dual-energy contrast-enhanced mammography
Dual-energy contrast-enhanced mammography is one of the latest developments in breast care. Imaging with contrast agents in breast cancer has already been described in previous magnetic resonance imaging and computed tomography studies. However, high costs, limited availability—or high radiation dose—led to the development of contrast-enhanced spectral mammography (CESM). Our most recent research evaluated this novel technique and was supported by GE Health Care (literature below). The research team focussing on the diagnosis of breast cancer has a vast experience with all of the imaging modalities currently used for evaluating the breast. In case of a suspicious imaging finding we perform fine needle aspiration and/or percutaneous biopsies using stereotaxy or ultrasound guidance. Our unit serves as the largest screening and assessment centre of the national breast-screening programme in Tirol. Approximately 10 000 mammograms and

breast ultrasound studies are performed each year making our unit the biggest in Austria.

Non-Invasive Cardiac/Cardiovascular Imaging

Gudrun Feuchtner

CT: 10 Multicenter trials
MRI: Pulse wave velocity (PWV) is the proposed gold-standard for the assessment of aortic elastic properties. It is the aim of this research project to use MR based pulse wave velocity imaging to assess aortic stiffness as a biomarker of myocardial wall stress.

Experimental Radiology

Wolfgang Recheis

Image processing and analysis including Rapid Prototyping based on radiological data represent core interests and tasks of the work group “Experimental Radiology”. These projects include multidimensional visualization, quantification of disease patterns based on texture analysis, shape analysis and others (see Fig. 3). Moreover, our new core facility micro-CT allows for the depiction of structures in µm scale in all three spatial dimensions.

Morphological and MR-Imaging

Benjamin Henninger, Christian Kremser

Morphological and functional MR-imaging in all organ systems development of novel MR-imaging applications and MR sequences
Examples of research projects:
a) MRI for the Evaluation of Diffuse Liver Disease: Evaluation of different MRI-methods (relaxometry, chemical-shift imaging, multi-echo approach, screening dixon) for the determination of diffuse liver disease

(fat, iron or combined disease); influence of iron on the evaluation of liver fat (see Fig. 4).

b) Diffusionweighted MRI of peripheral nerves (with M. Reinhold, Orth. Surgery)
Value of diffusion-weighted magnetic resonance imaging for the diagnosis and treatment of patients with lumbar nerve root entrapment syndromes.

c) Diffusion tensor imaging of the median nerve in carpal tunnel syndrome.
PI: A. Klauser

d) Assessment of tumour microcirculation by dynamic magnetic resonance imaging (DMRI): Tumour microcirculation is an important biomarker for diagnosis, therapy outcome prediction and therapy monitoring. In our study group DMRI is applied for these purposes to prostate carcinoma, rectal carcinoma, glioblastomas, etc.

e) MR Molecular Imaging using Nanoparticles. Recent developments in nanotechnology provide a wide spectrum of nano sized material for various applications, including tumour targeting and molecular imaging. The main task of our work in this field is to implement MR measurement techniques to facilitate the preclinical characterization and testing of such materials from varying research groups. Main contact: C. Kremser

Imaging of Prostate Cancer Image Fusion and Image Guided Biopsy of the Prostate

Multimodal Imaging of the GU-Tract

Friedrich Aigner, Daniel Junker

PSA is commonly used in screening for prostatic cancer. Patients with high PSA levels frequently undergo systematic

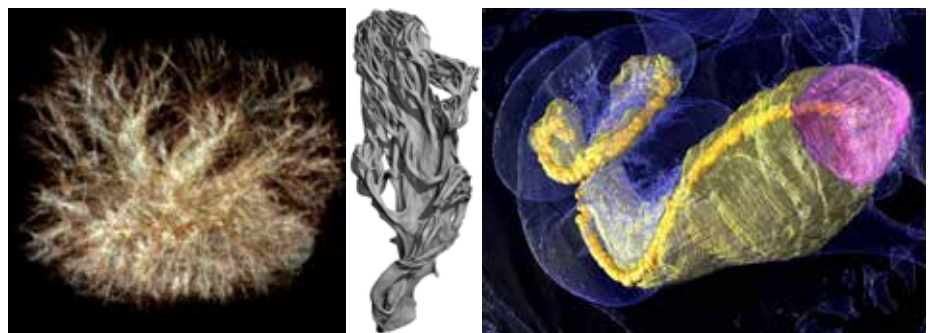

*Fig. 3: Left: Application of micro-computed tomography to microstructure studies of the medicinal fungus Hericium coralloides. Pallua JD, Kuhn V, Pallua AF, Pfaller K, Pallua AK, Recheis W, Pöder R., Mycologia. 2015 Jan-Feb;107(1):227-38. arrow) and of measurement of the height of the bone (white line)
Right: 3D Visualization of the round window (pink), the scala tympani (light yellow) and the length (measuring points= yellowish brown) of a sheep cochlea from micro CT datasets, which were used for round window area, cochlea length and scala tympani measurement.*

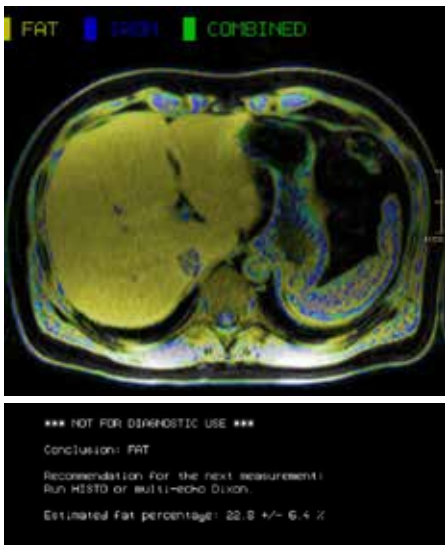

Fig. 4: Above: 43year old patient with suspected diffuse liver disease. The screening dixon sequence (work in progress package 718B, Siemens Healthcare) can provide a fast diagnosis of the predominant pathologic liver deposition - in this case it shows a fatty liver. Below: Automated two-point dixon screening for the evaluation of hepatic steatosis and siderosis: comparison with R2*-relaxometry and chemical shift-based sequences.

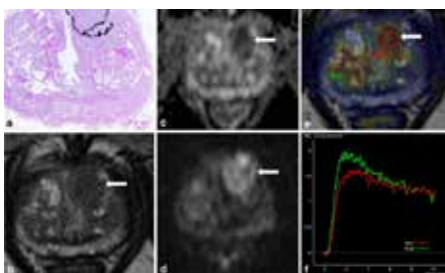

Fig. 5: A 67-year old patient with an anterior located Gleason score 7b prostate cancer in the transitional zone (PSA 5.69 ng/ml), encircled on the whole-mount step-section slide (a): The carcinoma (arrows) shows low signal on T2-weighted images with ill-defined margins (b), diffusion restriction on diffusion-weighted imaging (c, d), and hyperperfusion on dynamic contrast-enhanced MRI (e: red circle on perfusion map) with a focal plateau curve (f: red curve). An area with hyperplastic nodules appears unsuspecting in T2-weighted images (b), diffusion-weighted imaging (c, d), but shows hyperperfusion on dynamic contrast-enhanced MRI (e: green circle on perfusion map) with a focal wash-out curve (f: green curve), which is even more pathological (PI-RADS 5) than the perfusion of the carcinoma.

prostatic biopsies. However, PSA is not a reliable indicator for prostate cancer and systematic prostate biopsies are invasive and suffer from a rather high false negative rate. Thus, there exists the need for improving non invasive methods for detecting prostate cancer in its early stages. Our group has dealt with imaging of the prostate using ultrasound and multiparametric MRI for nearly 2 decades. Also, we used ultrasound since the early 90s for performing ultrasound guided biopsies. Recently, image fusion became available. We use ultrasound/MRI-fusion for guiding biopsies and avoiding “blind” systematic biopsies of the prostate. This approach improves the detection of cancer in large prostates, in the anterior portion of the prostate and in the inner gland. Also, reporting imaging results using the PI-RADS classification helps to avoid unnecessary biopsies. A low PI-RADS classification is a very reliable indicator for the absence of prostate cancer. Our results indicate, that patients with a high PI-RADS classification should undergo an image guided biopsy which has a much higher true positive rate than “blind” biopsies (see Fig. 5).

Musculoskeletal Imaging

Andrea S. Klauser et al.

- Sonography of Carpal tunnel: definition of cut off values
- Sonoelastography of epicondylitis: accuracy compared to histology
- Sonoelastography of plantar fasciitis: accuracy compared to histology
- Sonoelastography of achilles tendon: accuracy compared to histology
- US guided injections in CTS: Sonoelastographic appearance
- MR-Tractography (DTI, ADI) in median nerves in healthy volunteers and CTS patients: comparison to so-nography
- US guided injection in Sacroiliac joints of children: to prove feasibility
- DECT in gout: comparison to US, findings in extraarticular regions
- Hip Traction MRI (FIG)

Ultrasound

Hannes Gruber; Alexander Loizides

Research Focus of the Research Unit:

- Peripheral nerve sonography
- Sonographic evaluation of soft tissue masses
- Ultrasound guided injections in the spine
- Sonography of the musculoskeletal system
- Contrast enhanced sonography

The Section of surgical ultrasound is a

leader in the development of ultrasound techniques for evaluation of peripheral nerves and ultrasound guided nerve root infiltration and pain therapy. One of the most recent publications illustrates our work:

The axillary nerve (AN) is frequently injured during shoulder trauma and imaging is required to define the site and extent of nerve injury. However, the AN has a rather complex course through several soft tissue compartments of the shoulder and axilla. Therefore, imaging of the nerve with MRI and sonography is troublesome. Thus detection and sonographic assessment requires a thorough knowledge of local topography.

Our investigation is aimed at defining reliable anatomical landmarks for AN-sonography in 5 volunteers and later validating the proposed sonographic examination protocol in 10 unselected patients. With strict adherence to the proposed examination algorithm, sonography of the AN was feasible in all volunteers and patients. Furthermore, sonographic findings correlated nicely with the gold standard “surgical exploration” concerning the severity and topography of neural impairment.

Based on our study results we propose our algorithm for AN-sonography as the first-line imaging tool for the assessment of axillary nerve trauma. (PIC)

Interventional Oncology

Reto Bale

- Image guided tumor ablation
- Stereotaxy
- Robotics
- Targeting
- Interventional Oncology

Stereotactic Ablation of Liver Tumors:

Radiofrequency ablation (RFA) allows for local curative tumour treatment by inducing coagulation necrosis with a high-frequency alternating current. The major limiting factor of percutaneous ablation methods is the tumour size, requiring multiple overlapping ablation zones. 3D-planning allowing for the simultaneous display of multiple trajectories and increased accuracy is required. In addition, the virtual 3D plan has to be precisely transferred into the patient. Our team has developed frameless stereotactic aiming devices and immobilization devices for precise punctures in different body regions. Stereotaxy enables highly accurate ablation probe positioning in liver tumors. In 2001 the

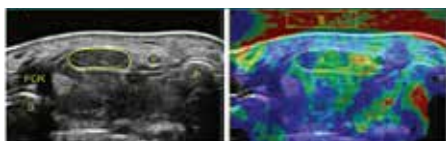

Fig. 6: Carpal tunnel syndrome: diagnosis by means of median nerve elasticity—improved diagnostic accuracy of US with sonoelastography (Miyamoto et al., 2014).

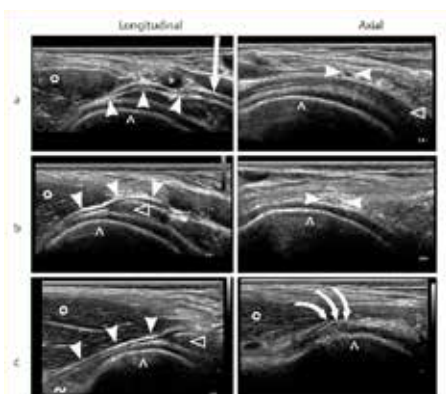

Fig. 7: The 2 US scans a (longitudinal and axial) show the sonographic situation at the “leaving” of the AN from the plexus. The 2 US scans b (longitudinal and axial) show the sonographic situation at the “middle segment” and the 2 US scans c (longitudinal and axial) show the sonographic situation at the “distal segment”. The white arrowheads indicate the AN, the white arrow indicates the posterior fascicle of the plexus, (*) indicates the axillary artery, (^) indicate the cortex of the humeral head, (Δ) indicate the subscapular muscle, the rings (o) indicate the teres minor muscle, (~) indicates the long head of the triceps muscle and the 3 bowed, white arrows indicate the 3 terminal branches of the AN forming within the axillary gap.

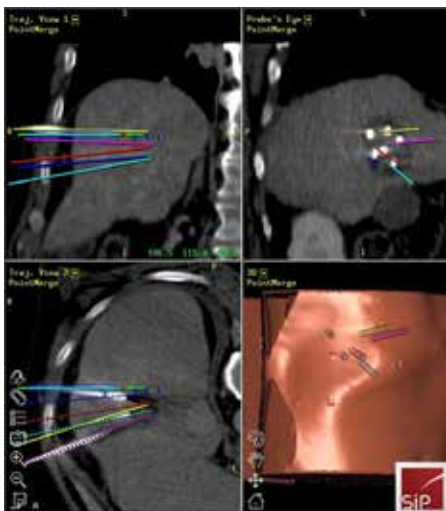

Fig. 8: Stereotactic Ablation of Liver Tumors.

worldwide first stereotactic radiofrequency ablation (SRFA) of a liver tumor was performed in Innsbruck. In the meantime more than 600 patients were successfully treated at our department. Recently a database was established and connected to the hospital information system (HIS). All the relevant information about every patient, treatment and follow-up examinations is continuously collected. Local recurrence rate, complications, long-term survival etc. can now easily be calculated. Currently the efficacy and long-term survival after SRFA is evaluated for different tumor entities. In addition, a major topic of research is the implementation of robotic devices for interventional procedures.

Theragnostics/Image Guided Tumor Therapy (Mitigate Project)

MITIGATE stands for Closed-loop Molecular Environment for Minimally Invasive Treatment of Patients with Metastatic Gastrointestinal Stromal Tumours.

Gastrointestinal stromal tumour (GIST) is a rare disease and frequently affects young patients and often results in a short life expectancy of less than 3 years. Currently there is only one class of effective medications for systemic GIST therapy and often the tumours develop drug resistance after a few years. The MITIGATE consortium representing three European universities, three research organisations and four SMEs will pursue the ultimate goal of developing new protocols and guidelines to effectively diagnose and treat patients with metastatic GIST resistant to current treatment.

MITIGATE is co-funded by the European Community’s Seventh Framework Programme (FP7/2007-2013) under grant agreement no 602306 and will run from October 2013-2017 (Fig. 9).

Selected Publications

Stereotactic Radiofrequency Ablation for Metastatic Melanoma to the Liver
Bale, Reto, Schullian, Peter, Schmutz, Matthias, Widmann, Gerlig, Jaschke, Werner, Weinlich, Georg, *CARDIOVASCULAR AND INTERVENTIONAL RADIOLOGY*; 2016; 39: S. 1128-1135

The high-risk criteria low-attenuation plaque <60 HU and the napkin-ring sign are the most powerful predictors of MACE: a long-term follow-up study.
Feuchtnr, Gudrun, Kerber, Johannes, Burghard, Philipp, Dichtl, Wolfgang, Friedrich, Guy, Bonaros, Nikolaos, Plank, Fabian, *EUROPEAN HEART JOURNAL-CARDIOVASCULAR IMAGING*; 2016; [Epub ahead of print]: S.

Excellent post-transplant survival in patients with intermediate stage hepatocellular carcinoma responding to neoadjuvant therapy.

Finkenstedt, A., Vikoler, A., Portenkirchner, M., Müller, K., Maglione, M., Margreiter, C., Moser, P., Vogel, W., Bale, R., Freund, M., Luger, A., Tilg, H., Petersen, J., Schneeberger, S., Graziadei, I., Zoller, H., Glodny, B., *LIVER INTERNATIONAL*; 2016; 36: S. 688-695

Gender influence on clinical presentation and high-resolution ultrasound findings in primary carpal tunnel syndrome: do women only differ in incidence?

Gruber, Leonhard, Gruber, Hannes, Djurdjevic, Tanja, Schullian, Peter, Loizides, Alexander, *JOURNAL OF MEDICAL ULTRASONICS*; 2016; 43: S. 413-420

Meralgia paraesthetica: Ultrasound-guided injection at multiple levels with 12-month follow-up

Klauser, Andrea S., Abd Allah, Mohamed M. H., Halpern, Ethan J., Sporer, Isabella, Martinoli, Carlo, Tagliacof, Alberto, Sojer, Martin, Taljanovic, Mihra S., Jaschke, Werner R., *EUROPEAN RADIOLOGY*; 2016; 26: S. 764-770

Sonoelastography of the Common Flexor Tendon of the Elbow with Histologic Agreement: A Cadaveric Study.

Klauser, Andrea S., Pamminer, Mathias J., Halpern, Ethan J., Abd Allah, Mohamed M. H., Moriggl, Bernhard, Taljanovic, Mihra S., Deml, Christian, Sztankay, Judith, Klima, Guenter, Gruber, Leonhard, Jaschke, Werner R., *RADIOLOGY*; 2016; [Epub ahead of print]: S. 160139

Evaluation of myocardial involvement in patients with connective tissue disorders: a multi-parametric cardiovascular magnetic resonance study

Mayr, Agnes, Kitterer, Daniel, Latus, Joerg, Steubing, Hannah, Henes, Joerg, Vecchio, Francesco, Kaesemann, Philipp, Patrascu, Alexandru, Greiser, Andreas, Groeninger, Stefan, Braun, Niko, Alschner, M. Dominik, Sechtem, Udo, Mahrholdt, Heiko, Greulich, Simon, *JOURNAL OF CARDIOVASCULAR MAGNETIC RESONANCE*; 2016; 18: S. 67

MR arthrography of the hip with and without leg traction: Assessing the diagnostic performance in detection of ligamentum teres lesions with arthroscopic correlation

Schmaranzer, Florian, Klauser, Andrea, Kogler, Michael, Henninger, Benjamin, Forstner, Thomas, Reichkendler, Markus, Schmaranzer, Ehrenfried, *EUROPEAN JOURNAL OF RADIOLOGY*; 2016; 85: S. 489-497

Ultralow dose dentomaxillofacial CT imaging and iterative reconstruction techniques: variability of Hounsfield units and contrast-to-noise ratio

Widmann, Gerlig, Bischof, Alexander, Stratis, Andreas, Kakar, Apoorv, Bosmans, Hilde, Jacobs, Reinhilde, Gassner, Eva-Maria, Puelacher, Wolfgang, Pauwels, Ruben, *BRITISH JOURNAL OF RADIOLOGY*; 2016; 89: S. 20151055

Pathogenesis, Diagnosis and Treatment of Hemochromatosis

Zoller, Heinz, Henninger, Benjamin, *DIGESTIVE DISEASES*; 2016; 34: S. 364-373

Selected Findings

- K-REGIO Projekt Cardiospect, Land Tirol, Wirtschaftsförderung, ao. Univ.-Prof. Dr. Michael Schocke
- MITIGATE #602306, EU FP7, o. Univ.-Prof. Dr. Werner Jaschke
- RLS-Iron, Land Tirol, Translationales Research Programm, ao. Univ.-Prof. Dr. Michael Schocke
- DISCHARGE #603266; EU FP7; ao. Univ.-Prof. Dr. Gudrun Feuchtnr
- Einsatz genetischer Algorithmen zur Erstellung realer, farbkodierter 3D-Modelle zur gleichzeitigen Darstellung von Hämodynamik und Morphologie in zerebralen arterio-venösen Malformationen; Autonome Provinz Bozen, PD Dr. Wolfgang Recheis
- Oralkarzinom WIF-273-01-00015/014-0034, Land Tirol, Translationales Research Programm, PD Dr. Wolfgang Recheis

Collaborations

- iSYS Medizintechnik GmbH
- Siemens Healthcare Österreich
- Ergospect GmbH

Core Facilities

- Micro CT
- Neuroimaging Research

Neuroradiology



Director:
Univ.-Prof.ⁱⁿ Dr.ⁱⁿ
Elke R. Gizewski MHBA

Contact:
 Anichstraße 35
 6020 Innsbruck

Elke.Gizewski@i-med.ac.at
 Phone: +43 512 504 27095
 Fax: +43 512 504 27096
<http://radiologie.tirol-kliniken.at>

Research Branch (ÖSTAT Classification)

301111, 301401, 302010,
 302043, 302044

Keywords

High-field MRI, MR-spectroscopy, fMRI, DTI, VBM, multimodal imaging, dual-energy-CT, interventional neuroradiology

Research Focus

Neuroradiological research is to a large extent connected to and driven by its clinical partners (Neuro-Focus at the MUI, e.g. neurodegenerative and neuroimmunological disorders, epilepsy, sleep medicine, degenerative spine diseases, brain tumors, neurovascular diseases, psychiatric diseases...). Besides those main partners, Neuroradiology is also involved in the projects of many other departments (clinical and theoretical) at the MUI, MCI and LFU.

Projects generated within the Department of Neuroradiology itself mostly focus on technical developments (dose reduction/dual energy CT, MRI-sequence developments, fMRI/VBM, 1H and 31P MR-Spectroscopy); some projects arise in cooperation with the Department of Radiology, and yet others arise from research experiences in the cerebral processing of pain with emphasis on gender differences. Beside these more

experimental projects, Neuroradiology also carries out clinical studies addressing neurovascular disease (Fig. 1), brain tumors and brain development. The Department of Neuroradiology administrates and leads the Core Facility Neuroimaging Research (CF-NIR).

General Facts

Structure of the Research Unit, Aims and Clinical Routine

The Department of Neuroradiology was established in 2012 and is therefore still under development. Together with the Department of General Radiology, the Neuroradiology is involved in the radiographer and physician educational programs, but also in research and clinical routine activities. Furthermore, the two departments have a long-standing PhD program, and they also started a clinical PhD program in 2013.

Neuroradiology is a department with a large clinical workload, which includes diagnostic and interventional neuroradiology for all neuro-cases both of pediatric and of adult patients. One focus of research is clinically related imaging and intervention studies (including multicentre studies, e.g. SITS open, ACTS II). The senior physicians lead the younger colleagues with interest in neuroradiology and the PhD students of the Department in all aspects of clinical studies, and cooperate with clinical part-

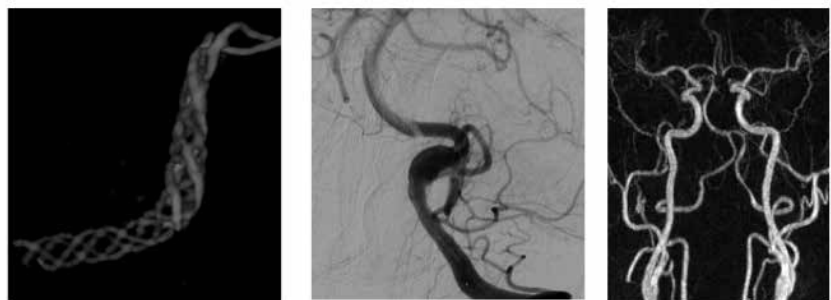

Fig. 1: Endovascular therapy of cerebral aneurysms is more and more important in clinical routine. The first row shows a recent development in stents which is here evaluated in clinical studies.

The second row shows an example of endovascular stroke therapy with thrombectomy using one of the recently developed stent retrievers (arrows). Here, the Neuroradiology (in cooperation with Neurology) is part of a big multicentre study.

ners within the MUI (mainly Neurology, Neurosurgery, Psychiatry, Child and Youth Psychiatry, Neuropediatrics, Radiology, but also Gynecology, ENT, Nuclear Medicine, Cardiology, Neonatology, Radiation Therapy, Orthodontics and others).

The more experimental research is still developing. Up to now, Neuroradiology has 2 “Laufbahnstellen” (Tenure Track positions) with Ass. Profs. who lead their own research groups: “Diffusion Tensor Imaging (DTI) of spine and nerves” and “Multimodal imaging with focus on MR-Spectroscopy”. Within the latter group, one PhD student began studies in 2015 (ÖNB grant) with focus on ³¹P MR-Spectroscopy (MRS) in cerebral diseases; MRS and multimodal imaging represent a significant focus of the Department (Fig. 2).

One research focus of the Head of the department is the cerebral processing of pain. She was co-PI of two DFG-funded research projects dealing with visceral pain imaging: “Extinction learning” and “Placebo modulation of visceral pain processing”, and is now translating that experience to local research (Fig. 3, and project listed below). The extensive experience with high field MRI (3T and 7T (now in cooperation with the Erwin L Hahn Institute in Essen, with the Excellence Centre of High Field MRI at the Medical University Vienna, and with the Imaging Unit of the DKFZ in Heidelberg)), both structural and fMRI (multimodal) also represent a further focus on brain processing related to cognitive and emotional processes, particularly with respect to possible gender differences. The fMRI group has a second focus on psychiatric research (resilience, affective disorders, eating disorders), and also on critical emotional situations arising in cardiology.

The Department of Neuroradiology has also a considerable number of collaborations outside the MUI.

Core Facility Neuroimaging Research (CF-NIR)

The main modality of this CF is the BMWF-funded 3 Tesla-MRI-system, which establishes a core facility for MR-based neuroimaging research at the MUI. The 3T MRI was installed in 2011 and started work exclusively for research use in 2012. The CF-NIR is centrally administered by the Head of the Department of Neuroradiology, who leads an interdisciplinary Steering Board. The technical equipment is supported by one physicist (since 2014)

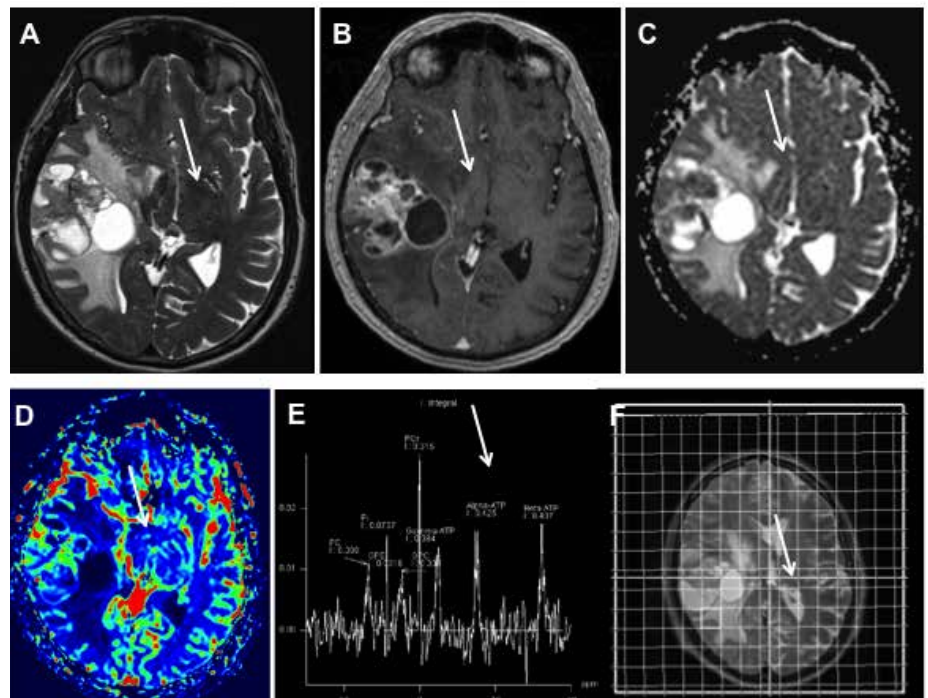

Fig. 2: Multimodal imaging in tumor patients. Multicystic WHO grade IV glioma on the right hemisphere with edema in T2 weighted images (A, arrow), contrast-enhancement (B, arrow), restricted diffusion (C, arrow) and increased perfusion (D, arrow) of the solid parts. ³¹P MRS spectrum, displaying the high energy metabolites phosphocreatine (PCr, arrow) and ATP (E), the arrow is pointing at the relevant voxel.

and an assistant radiographer. The Team “Neuroradiology” provides support to all associated scientists in technical and post-processing questions. Furthermore, the core facility develops and introduces new MR sequences and technical equipment, such as improved coils. Above all, the Neuroimaging platform offers opportunities to bring different groups together and to transfer knowledge, and it provides a setting for communication and cooperation.

One important recent development with the CF-NIR is the **Neuroimage WING**, which is a grant (Hochschulraumstrukturmittel) supporting an imaging platform at the Medical Universities Innsbruck, Graz and Vienna. Neuroimage WING (WienInnsbruckGraz) is led by MUI (Department of Neurology, Univ.-Prof. Dr. Christoph Scherfler: “Computational Neuroimaging”, in cooperation with the Department of Neuroradiology) and was set up to collect and analyse data from different sites and from pooled patient populations. This will lead to higher efficiency and synergies in research projects and also to a know-how transfer. Multiple sclerosis, movement disorders and dementias were defined as the starting projects.

Research

This section lists only those research projects which are mainly led by Neuroradiology (NR). Further collaborations, mainly those involving the CF-NIR, have undertaken many additional projects, and yet other projects work with many further radiological techniques.

Attachment and Cerebral Processing

led by Prof. Dr. Buchheim and Prof. Dr. Gizewski, in cooperation with Dr. Labisch and Prof. Viviani

Attachment is a core function in healthy human life, but it is vulnerable in patients with psychiatric diseases. Well known tools such as the “Adult Attachment Projective Picture System” are available; however, this imaging system is not optimal for use in fMRI experiments. The goal of this study is to evaluate a new imaging suite we created, which is especially adapted for fMRI in healthy volunteers in a 3T MRI setting.

Cerebral Processes of Enteroceptive Pain in Patients with Dysmenorrhoea

led by Prof. Gizewski; NR: Dr. Siedentopf, Dr. Steiger in cooperation with Prof. Wildt, Dr. Böttcher, and Prof. Elsenbruch (Essen)

Pelvic pain is an important symptom having high impact in clinical care and therapy. There are several relevant pelvic pain types, including primary and secondary dysmenorrhea. To date, there is no study that addresses interoceptive pain thresholds, subjective perception of pain, and cerebral processing of such stimuli in patients with dysmenorrhea. The rectal barostat distension model, which is well established in the Essen laboratory and has now been transferred to Innsbruck, is a clinically relevant, valid and reliable interoceptive pain model. This paradigm is now being used in a pilot study on dysmenorrhea patients, with the first results showing typical activation in “pain matrix” areas.

Cerebral Processing of Food Stimuli in Young Anorectic Patients in Respect to Personality Disorders and Gender

led by Prof. Gizewski, Prof. Sevecke, in cooperation with NR: Dr. Steiger, Child and Youth Psychiatry: Dr. Fuchs

Some earlier studies have revealed alterations in cerebral processing in adult anorectic patients. However, since they were based on longstanding disease, their results could not give clear answers on how those functional and structural differences developed in contrast to healthy volunteers. We have therefore established the application of these stimuli to young patients and will correlate the measured brain param-

eters (Fig. 3) with psycho-social data.

Resilience: Neuroimaging of Gender Differences in Healthy Subjects

led by Prof. Hofer and Prof. Gizewski in cooperation with NR: Dr. Siedentopf

Resilience represents the capacity of some individuals to remain healthy or recover easily from adverse events, despite marked negative circumstances and risk factors, whereas others under comparable conditions are particularly vulnerable to disorders and illness. Few studies have examined the structural correlates of resilience, and they involved mostly subjects under risk circumstances or suffering post-traumatic stress disorder (PTSD). The Neuroradiology is involved in this study firstly by analyzing a cross-sectional survey to investigate resilience in healthy volunteers, with a primary focus on potential gender differences, and secondly by addressing the cerebral representation of resilience in the same individuals, with emphasis on gender specificities.

MRI and MRS Parameters in Cerebral Development of Preterm Infants

led by Dr. Djurdjevic in cooperation with Prof. Kiechl-Kohlendorf, Prof. Gizewski and Prof. Buchheim

Up to now, some studies have revealed structural parameters in preterm children that indicate an unfavourable clinical outcome (e.g. the Innsbruck NEOBRAIN study). These first results led to formulate further

hypotheses and to develop a study addressing not only structure but also metabolism in preterm children, using MRS. Additionally, fMRI and psychological tests will be applied to obtain data from grown-up former preterm children.

31P MRS in Cerebral Gliomas and Metastases

led by Ass.-Prof. Grams; NR: Dr. Walchhofer and Dr. Steiger in coop. with Prof. Thomé, Dr. Kerschbaumer, Dr. Freyschlag, Prof. Stockhammer and Dr. Nowosielski, Prof. Nevinny-Stickel

By using MR spectroscopy of phosphorus compounds (31P MRS) it is possible to detect various metabolites of energy metabolism and of membrane turnover. 31P MRS is being applied in patients with cerebral gliomas and metastases in order to investigate tumour heterogeneity and the effects of therapy not only on the tumorous area but on the healthy brain hemisphere as well. The resulting data will be correlated with results obtained from established methods such as 1H MR spectroscopy, MR perfusion- and MR diffusion-weighted imaging, as well as with clinical, histological and PET parameters.

31P MRS in Stroke Patients

led by Ass.-Prof. Grams; NR: Dr. Walchhofer and Dr. Steiger in cooperation with Prof. Willeit and Dr. Knoflach

31P MRS is being applied in patients with acute, subacute and chronic ischemic stroke to gain further insights into the energy metabolism and reorganization mechanisms of infarcted brain and surrounding areas during the acute stage, and to monitor subacute and chronic changes. The results will be correlated with those obtained from established imaging methods (see above) and with clinical data that are routinely collected in the Department of Neurology.

31P MRS in Healthy Volunteers and Brain Trauma Patients

led by Ass.-Prof. Grams; NR: Dr. Walchhofer, Dr. Steiger in cooperation Prof. Thomé, Dr. Petr, and Dr. Pinggera

31P MRS is being performed in patients with severe traumatic brain injury during the acute, sub-acute and chronic stages. Trauma influence on energy metabolism and on reorganization processes will be investigated and the results correlated with established imaging parameters (see above) and with clinical parameters.

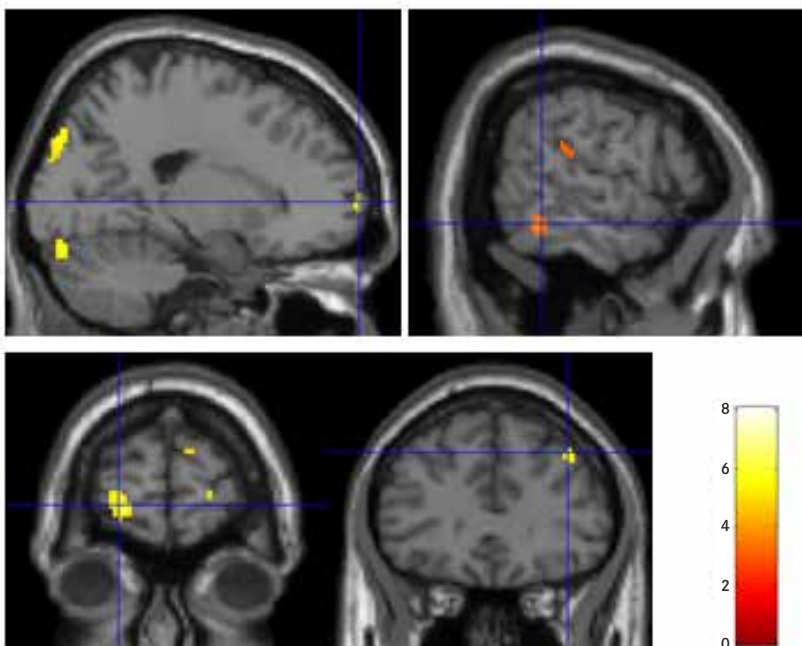

Fig. 3: Activation of orbitofrontal, prefrontal and medial temporal gyrus in contrast of high-calorie food and low-calorie food in the group of anorectic patient in contrast to the control group. These areas are involved in altered perception and rating strategies of food but also in body perception (medial temporal gyrus).

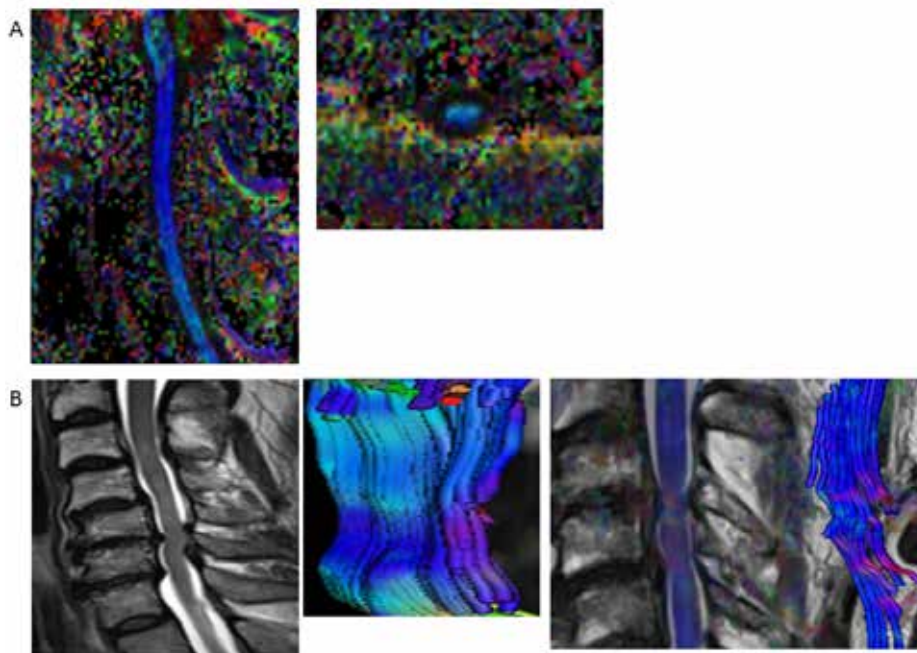

Fig. 4: A shows an optimized DTI sequence from a healthy volunteer. The anisotropy can be calculated without significant artefacts and the tracts can be visualized in both sagittal and transverse orientation with high resolution. 4B shows two patients with degenerative spine disease and visualizes tract disturbances.

DTI of Spinal Cord

led by Ass.-Prof. Dr. Cartes-Zumelzu;
Radiology: Dr. Kremser in cooperation with
Prof. Thomé, Prof. Feuchner, Prof. Granata,
PD Dr. Broessner and
Siemens Medical Imaging

DTI is well established for analysis of white matter and brain structure. However, this method might also be helpful in spinal imaging, especially in degenerative diseases. However, it offers many challenges. The sequence used is influenced by many anatomical structures which cause artefacts, and it also has limited resolution. This project successfully optimized the sequence and then started the study of the first patients showing degenerative cervical changes with narrowing of the spinal canal (Fig. 4).

Dual Energy CT in Stroke Patients

led by Ass.-Prof. Grams; NR: Dr. Kurz in cooperation Prof. Poewe, Ass.-Prof. Glodny, Prof. Willeit, Dr. Knoflach, and Prof. Ortler
Dual energy computed tomography (DECT) can distinguish up to three different materials or tissues. Various projects are investigating the differentiation of blood-brain-barrier disruption, haemorrhage, thromboembolic material, and infarcted and healthy brain, and are correlating them with conventional CT.

Dual Energy CT for Artefact Reduction in Patients with Cranial and Spinal Implants

led by Ass.-Prof. Grams; NR: Prof. Gizewski, Dr. Kurz, in cooperation with Ass.-Prof. Glodny, Prof. Ortler, Prof. Crismani
DECT also offers the opportunity to reduce beam-hardening artefacts from metal implants by extrapolation of monochromatic (MC) series. This method is being applied in patients with cerebral clips, dentogenic and spinal implants. The aim of these studies is to evaluate the presence of artefacts and to assess the surrounding tissue, in comparison to conventional computed tomography.

Methods of Quantifying Supra-Aortal and Intracranial Artery Calcifications

led by Ass.-Prof. Grams; NR: Dr. Steinkohl, in cooperation Ass.-Prof. PD Glodny, PD Dr. Beer, PD Dr. Helbok, Prof. Ortler and Dr. Julia Kerschbaum

A method developed in our department to quantify aortal calcification is being applied to examine the supra-aortal and intracranial arteries. The amount of calcification will be correlated with the incidence of intracranial aneurysms or cerebral vasospasm after a subarachnoid haemorrhage.

Selected Publications

Neural Correlates of the Appraisal of Attachment Scenes in Healthy Controls and Social Cognition - An fMRI Study

Labek, Karin, Viviani, Roberto, Gizewski, Elke R., Verius, Michael, Buchheim, Anna,
FRONTIERS IN HUMAN NEUROSCIENCE: 2016; 10: S. 345

Loss of Dorsolateral Nigral Hyperintensity on 3.0 Tesla Susceptibility-Weighted Imaging in Idiopathic Rapid Eye Movement Sleep Behavior Disorder

De Marzi, Roberto, Seppi, Klaus, Hoegl, Birgit, Mueller, Christoph, Scherfler, Christoph, Stefani, Ambra, Iranzo, Alex, Tolosa, Eduardo, Santamaria, Joan, Gizewski, Elke, Schocke, Michael, Skalla, Elisabeth, Kremser, Christian, Poewe, Werner,
ANNALS OF NEUROLOGY: 2016; 79: S. 1026-1030

1.5 Versus 3 Tesla Magnetic Resonance Planimetry in Neurodegenerative Parkinsonism

Mangesius, Stephanie, Krismer, Florian, Gizewski, Elke R., Mueller, Christoph, Hussl, Anna, Schocke, Michael, Scherfler, Christoph, Poewe, Werner, Seppi, Klaus,
MOVEMENT DISORDERS: 2016; 31: S. 1925-1927

Endovascular stroke therapy in Austria: a nationwide 1-year experience

Serles, W., Gattringer, T., Mutzenbach, S., Seyfang, L., Trenkler, J., Killer-Oberpfalzer, M., Deutschmann, H., Niederkorn, K., Wolf, F., Gruber, A., Hausegger, K., Weber, J., Thurnher, S., Gizewski, E., Willeit, J., Karaic, R., Fertl, E., Nasel, C., Brainin, M., Erian, J., Oberndorfer, S., Karmel, F., Grisold, W., Auff, E., Fazekas, F., Haring, H.-P., Lang, W., Austrian Stroke Unit Registry Coll,
EUROPEAN JOURNAL OF NEUROLOGY: 2016; 23: S. 906-911

Longitudinal profile of iron accumulation in good-grade subarachnoid hemorrhage

Scherfler, Christoph, Schiefficker, Alois Josef, Delazer, Margarete, Beer, Ronny, Bodner, Thomas, Spinka, Georg, Kofler, Mario, Pfausler, Bettina, Kremser, Christian, Schocke, Michael, Benke, Thomas, Gizewski, Elke R., Schmutzhard, Erich, Helbok, Raimund,
ANNALS OF CLINICAL AND TRANSLATIONAL NEUROLOGY: 2016; 3: S. 781-790

Placebo analgesia in patients with functional and organic abdominal pain: a fMRI study in IBS, UC and healthy volunteers.

Schmid, J., Langhorst, J., Gaß, F., Theysohn, N., Benson, S., Engler, H., Gizewski, ER., Forsting, M., Elsenbruch, S.,
GUT: 2015; 64: S. 418-427

Between- and Within-Site Variability of fMRI Localizations

Rath, Jakob, Wurnig, Moritz, Fischmeister, Florian, Klingner, Nicolaus, Hoellinger, Ilse, Geissler, Alexander, Aichhorn, Markus, Foki, Thomas, Kronbichler, Martin, Nickel, Janpeter, Siedentopf, Christian, Staffen, Wolfgang, Verius, Michael, Golaszewski, Stefan, Koppelstaetter, Florian, Auff, Eduard, Felber, Stephan, Seitz, Ruediger J., Beisteiner, Roland,
HUMAN BRAIN MAPPING: 2016; 37: S. 2151-2160

Residual Thromboembolic Material in Cerebral Arteries after Endovascular Stroke Therapy Can Be Identified by Dual-Energy CT

A.E. Grams, M. Knoflach, R. Rehwald, J. Willeit, M. Sojer, E.R. Gizewski and B. Glodny,
AMERICAN JOURNAL OF NEURORADIOLOGY: 2015; 36: S.1413-1418

Selected Funding

- Characterization of brain metabolism in ischemic stroke with MR spectroscopy of phosphorous compounds, ÖNB, Dr. Grams
- As Co-investigator: Myocardial MRS correlates of cardiac sympathetic Denervation in PD, FWF, Prof. Wenning and Center Neuroimaging / Neuroimage WING, BMWFS, Prof. Scherfler
- „Emotionserkennung und soziale Kognition bei JME Patienten“, FWF, PI Prof. Trinka

Collaborations

- Austria: NEUROIMAGE WING (BMWFS grand: pooled MRI data collection and analysis Med. Universities Innsbruck, Graz, Wien (Neurology and Neuroradiology, 7T MRI), MCI Innsbruck
- Germany: University Hospital Essen (Medical Psychology & Behavioural Immunobiology, Forensic Psychiatry, Neurology, Neurosurgery, Radiology), Erwin L. Hahn Institut Essen, DKFZ Heidelberg/MR-Imaging, Justus-Liebig University Giessen (Neurology, Neuroradiology, Neuropediatrics), University Marburg (Neurology), LMU Munich and Technical University Dresden (Neuroradiology), University Hamburg (Neuroradiology), Goethe University Frankfurt (Neuroradiology), University Tübingen (Psychosomatic Medicine)
- Switzerland: Hirslanden Clinic Zürich, Neuroradiology

Core Facilities

Neuroimaging Research Core Facility (3T MRI)

Prosthodontics, Restorative Dentistry and Periodontology



Director:
Univ.-Prof. in DDR. in Ingrid Grunert

Contact:
Anichstraße 35
6020 Innsbruck

Ingrid.Grunert@i-med.ac.at
Phone: +43 512 504 27159
Fax: +43 512 504 27157
www.zmk-innsbruck.at

Research Branch (ÖSTAT Classification)

302088, 302029

Keywords

Dental ceramics, composite materials, adhesive technique, CAD/CAM dentistry, dental implants, removable complete dentures, periodontitis, rare diseases

Research Focus

- Dental ceramics
- Composite filling materials and adhesive systems
- CAD/CAM dentistry
- Rare diseases with oral phenotypes

General Facts

The University Hospital for Dental Prosthetics and Restorative Dentistry is part of the Department of Dental and Oral Medicine and Cranio-Maxillofacial and Oral Surgery.

Our main focus is the education and training of pre-doctoral students. Currently, about 80% of the dental curriculum is covered by our department. The student education

comprises theoretical lectures and practical training on phantom models, as well as supervised patient treatment. The Innsbruck dental education uses the “integrative therapeutic concept”, which teaches the students how to perform a full dental treatment, including oral hygiene instruction, restorative treatment and, when necessary, prosthodontic rehabilitation on each patient. Our main goal is to teach evidence-based dentistry in a close supervisory relationship.

Besides educating dental students, the University Hospital for Dental Prosthetics and Restorative Dentistry has also developed, and currently provides, the Austrian admissions test for dental medicine (MED-AT-Z test), which is used as access limitation to all Austrian public dental schools. For degree thesis and research, the department also owns research laboratories well-equipped for *in-vitro* testing of dental materials. Particularly our research and clinical expertise on dental ceramics are of international standing, and our publications on this topic have a high citation index.

Research

Dental Ceramics, Composite Filling Materials and Adhesive Systems

René Steiner, Mathias Keller,
Herbert Dumfahrt

Dental ceramic and composite restorations have become an indispensable part of modern dentistry, as they satisfy the patient's demand for aesthetic restorations

while allowing substance-preserving tooth preparations. Both ceramic and composite materials are bonded to the tooth structures using adhesive techniques. While composite materials are bonded directly onto dentin or enamel, dental all-ceramic restorations are fixed by using resin cements. Many of the currently available resin cements are dual-curing. This means that they consist of a light curing and a self-curing component. Insufficiently cured cement causes clinical failure due to disintegration over time. Our studies have found that the self-curing component of dual-curing resin cements is not able to fully cure the cement on its own. As a consequence, we have investigated the influence of light absorption caused by ceramic thickness and opacity on the cement curing degree. Further pursuing this approach, we have also investigated the influence of different light-curing protocols on the bonding strength of different composite resins to human dentin using push-out tests in a universal testing machine, during which a steadily increasing load is applied onto the bonded composite (figure 1C). The test results showed that the bonding strength between composite resin and dentin is substantially influenced by the intensity of the curing light, whereas the use of different adhesive systems does not have a significant influence. The same experimental setting was used to evaluate the bonding strengths of different composite types to dentin. A particular focus was set on so-called bulk-fill composites, which allow the treatment

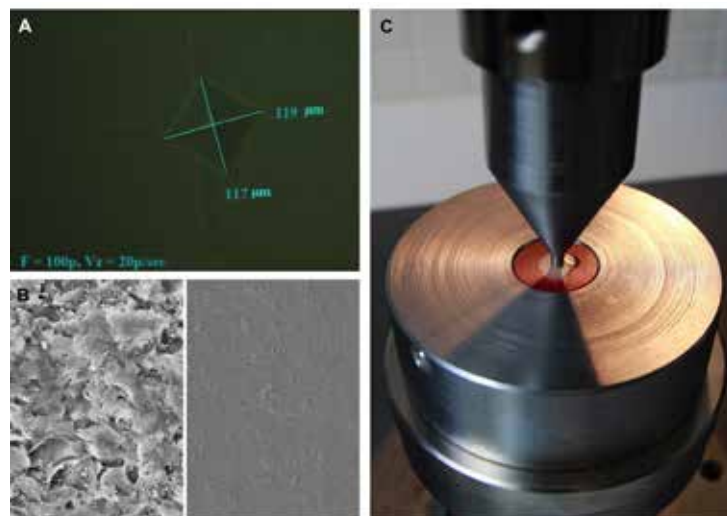

Fig. 1: (A) Indentation deepness of a diamond tip on dual-curing resin cements as criterion for hardness, tested by a Micro-Vickers-Hardness tester. (Incident light microscopic image; $\times 400$ magnification); (B) Scanning electron micrographs of dental ceramic, comparing roughened and polished ceramic surfaces (Representative micrographs; $\times 1000$ magnification); (C) Push-out procedure applying a steadily increasing load until detachment of the composite core, tested in a universal testing machine.

of up to 4 mm deep cavities in one clinical step. Contrary to the expectations, the bulk-fill composites did not achieve satisfactory bonding strength values, while flowable composite resins, surprisingly, performed best. The frequently used universal composites achieved satisfactory bonding strength values. Our results indicate that flowable composite may be the most favourable material for restorations submitted to no or only minimal occlusal stress. Bulk-fill composites, on the other hand, should only be used with some reservations, as sufficient long-term durability may not be guaranteed.

CAD/CAM Dentistry

PI: Patricia-Anca Steinmassl;

Researchers: Raphael Antretter, David Juranek, Florian Klaunzer, Lukas Ruech; Senior Investigators: Herbert Dumfahrt, Ingrid Grunert;

Computer aided design and computer aided manufacturing (CAD/CAM) gains increasing importance in dentistry. Digital impression taking can reduce treatment expenditure and increase patient comfort. Digitally designed and manufactured fixed and removable prosthodontic restorations have a high degree of precision, as well as production-specific material advantages. Besides revolutionising patient treatment procedures, digital dentistry also provides new option of automatizing the evaluation of students' practical performance.

The Innsbruck CAD/CAM research group has three main focuses of high topicality:

- CAD/CAM fabricated removable complete dentures
- CAD/CAM fabricated fixed prosthodontics
- Digital evaluation of students' practical performance

Major Achievements:

The Innsbruck CAD/CAM research group has provided first evidences on material-properties of CAD/CAM fabricated denture bases. The clinically highly relevant results show that CAD/CAM dentures have more favourable surface properties and a higher precision of fit than conventionally fabricated dentures, but do not release less MMA monomer. Clinical evaluations will follow. Our studies involving intraoral scanning of tooth preparations for fixed prosthodontic restorations have shown that CAD/CAM fabricated restorations are very precise, but are currently limited to shoulder preparations. Chamfered preparations cannot be replicated in sufficient quality yet. In addition, the Innsbruck CAD/CAM research

group has developed a protocol enabling the automatized, objective evaluation of practical performances, which replaces the less reproducible subjective evaluations. Three master thesis supervised by members of the CAD/CAM research group have been awarded with the "VTZ-Preis", one graduate's presentation on the topic of removable CAD/CAM dentures has won the Austrian Dental Award for the best oral presentation 2016, and in 2015 the project on the evaluation of material-specific properties of CAD/CAM fabricated dentures has been awarded with the "ODV Wissenschaftspreis".

Future Goals:

Besides further pursuing ongoing projects, the CAD/CAM research group works on integrating digital dentistry into student education. A step-by-step plan for familiarising the students with the new, computer-based processes is currently being developed.

Hereditary Diseases with Oral Phenotypes

Ines Kapferer-Seebacher, Irene Heiss-Kisielewsky, Dagmar Schnabl

Molecular investigations of rare Mendelian forms of diseases contribute to our understanding of gene functions and may expose critical new pathways involved in the molecular pathogenesis of common health problems. In periodontal Ehlers-Danlos syndrome (EDS) we have found a novel and surprising link between the inflammatory classical complement pathway and connective tissue homeostasis. Periodontal EDS is a specific subtype of EDS, a group of rare connective tissue diseases. As part of an international collaboration, we delineated the spectrum of clinical features of periodontal EDS in 19 independent families comprising 107 affected individuals. We further determined that periodontal EDS is caused by gain of function mutations of the complement 1 subunits C1r and C1s and provided data on the possible pathomechanism. To further elucidate this new link between the inflammatory classical complement pathway and connective tissue homeostasis, a FWF grant has been awarded. In 2016, a joint consultation for hereditary diseases with dental and /or dermatological phenotypes has been established in collaboration with the Division of Human Genetics and the Department of Dermatology, Venereology and Allergology. As a consequence, clinical phenotypes and the molecular basis of several rare diseases with dental phenotypes have been described by our group. For example, SLC13A5 has been described as second gene associated with Kohlschüt-

ter-Tönz syndrome. Clinical and histological evaluation of teeth identified distinct differences between Kohlschütter-Tönz syndrome caused by different mutations. In Jeune asphyxiating syndrome, molar-incisor-malformation was linked to ciliary dysfunction due to mutations in TCTEX1D2 for the first time.

Selected Publications

Periodontal Ehlers-Danlos Syndrome Is Caused by Mutations in C1R and C1S, which Encode Subcomponents C1r and C1s of Complement

Kapferer-Seebacher, Ines, Pepin, Melanie, Werner, Roland, Aitman, Timothy J., Nordgren, Ann, Stoiber, Heribert, Thielens, Nicole, Gaboriaud, Christine, Amberger, Albert, Schossig, Anna, Gruber, Robert, Giunta, Cecilia, Bamshad, Michael, Bjorck, Erik, Chen, Christina, Chitayat, David, Dorschner, Michael, Schmitt-Egenolf, Marcus, Hale, Christopher J., Hanna, David, Hennies, Hans Christian, Heiss-Kisielewsky, Irene, Lindstrand, Anna, Lundberg, Pernilla, Mitchell, Anna L., Nickerson, Deborah A., Reinstein, Eyal, Rohrbach, Marianne, Romani, Nikolaus, Schmutz, Matthias, Silver, Rachel, Taylan, Fulya, Vandersteen, Anthony, Vandrovцова, Jana, Weerakkody, Ruwan, Yang, Margaret, Pope, F. Michael, Byers, Peter H., Zschocke, Johannes, Mol Basis Periodontal EDS Consorti, Aleck, K., Banki, Z., Dudas, J., Dumfahrt, H., Haririan, H., Hartsfield, J.K., Kagen, C.N., Lindert, U., Meitinger, T., Posch, W., Pritz, C., Ross, D., Schroer, R.J., Wick, G., Wildin, R., Wilflingseder, D., AMERICAN JOURNAL OF HUMAN GENETICS: 2016; 99: S. 1005-1014

Shortcomings of prosthodontic rehabilitation of patients living in long-term care facilities

Steinmassl, P.-A., Steinmassl, O., Kraus, G., Dumfahrt, H., Grunert, I., JOURNAL OF ORAL REHABILITATION: 2016; 43: S. 286-290

Is Cognitive Status Related to Oral Hygiene Level and Appropriate for Determining Need for Oral Hygiene Assistance?

Steinmassl P.-A., Steinmassl O., Kraus G., Dumfahrt H., Grunert I. JOURNAL OF PERIODONTOLOGY: 2016; 1: S. 41-47.

Adjusting dental ceramics: An in vitro evaluation of the ability of various ceramic polishing kits to mimic glazed dental ceramic surface

Steiner, Rene, Beier, Ulrike S., Heiss-Kisielewsky, Irene, Engelmeier, Robert, Dumfahrt, Herbert, Dhima, Matilda, JOURNAL OF PROSTHETIC DENTISTRY: 2015; 113: S. 616-622

Selected Findings

- Functional implications of C1r and C1s proteases alterations identified in patients with Ehlers-Danlos syndrome periodontal-type
- Fonds zur Förderung der wissenschaftlichen Forschung, FWF
- I.Kapferer-Seebacher together with Johannes Zschocke (Division of Human Genetics, MUI) and Heribert Stoiber (Division of Virology);

Collaborations

- Poliklinik für Zahnärztliche Prothetik, Ludwig-Maximilians-Universität München, Munich, Germany
- Institute of Analytical Chemistry and Radiochemistry, University of Innsbruck, CCB, Innsbruck, Austria
- Swarovski Research and Development Department, Wattens, Austria
- Dr. Christine Gaboriaud and Dr. Nicole Thielens, Groupe IRPAS (Immune response to pathogens and altered self), Institut de Biologie Structurale, Grenoble, France
- Prof. Dr. Adrian Lussi und Prof.Dr. Dieter Bosshard, Zahnmedizinische Kliniken der Universität Bern, Bern, Schweiz

Orthodontics



Director:
Univ.-Prof. Dr. Adriano Crismani

Contact:
Anichstraße 35, MZA
6020 Innsbruck

Adriano.Crismani@i-med.ac.at
Phone: +43 512 504 27194
Fax: +43 512 504 27199
www.zmk-innsbruck.at/
Kieferorthopaedie.9.0.html

Research Branch (ÖSTAT Classification)

302033, 302034, 302044,
302073, 211904

Keywords

Skeletal anchorage, bio-functionalisation, adhesives and debonding, dental agenesis, 3D-printers, non-compliance class-II-appliances, indirect bonding

Research Focus

The investigation of different removal parameters by a confocal microscope with regard to surface homogeneity, e.g. abrasive polisher and rotational speed.

The investigation of transfer accuracy of different indirect bonding methods by means of scans and 3D-inspection software.

The investigation of abutment transfer with impression materials when using palatal anchorage by means of scans and 3D-inspection software.

General Facts

The University Clinic of Orthodontics consists of the head and two residents. No ex-

tra lab-staff exists.

The research topics are mainly derived from questions of clinical relevance: impression material accuracy for palatal orthodontic mini screws, skeletal and dentoalveolar changes due to a class II correction with a non-compliance-appliance, transfer accuracy of two indirect bonding techniques, and Enamel surface quality after adhesive remnant removal are examples of such an approach. Many collaborations were initiated inside the campus in Innsbruck: Institute of Anatomy, University Clinic of Cranio-, Maxillofacial and Oral Surgery, University Clinic of Radiology etc. For outside collaborations and core facilities see below.

Research

Impression Material Accuracy for Palatal Orthodontic Mini Screws

Adriano Crismani

With current model scanners, dental casts and similar objects can be easily compared in 3D reference programs. Orthodontic mini screws have become an important tool in orthodontic practice. This study investigates the accuracy of abutment transfer with current impression materials and tries to give a compact overview with other factors relevant to permit an informed decision for the optimal impression for this treatment method. 96 impressions of a cadaver head with two orthodontic mini screws in place were taken with four impression materials: Alginate (Palgat™ Plus), a monophasic polyvinylsiloxane (Imprint™4 Preliminary), a biphasic polyvinylsiloxane (Imprint™4 Penta™ Putty and Imprint™ 4 light) and a polyether (Impregum™ Penta) by two observers (experienced, inexperienced) and in two methods of application (application in a perforated metal tray with or without local application near transfer caps). After pouring with a standard type IV stone (silky rock yellow) and abutment transfer, all models and the upper jaw (which had been separated from the head) were scanned in a standard model scanner (Zirkonzahn S600 ARTI) and evaluated in a CAD-program (GOM-Inspect). The deviations measured in 6 points per screw and statistically evaluated with SPSS®. Optimal values were obtained with the biphasic PVS. Observer experience showed no effect, the method of application showed a minor effect on accuracy. Within the limitations of this study, it seems all impression materials are suited for mini screw abutment transfer, if means of intraoral adaptation of the orthodontic appliance can be performed. If higher accuracy is needed and for inexperienced



Fig. 1: Mini Screws inserted in the palate of a cadaver before impression with different materials

clinicians, a biphasic PVS impression with intraoral light body and heavy body application in tray should be used (putty-wash), due to the combination of setting times. The most cost-effective version, alginate, can be used if consequences of stronger deviations can be handled. If sterilisation is necessary, as in highly infectious patients, alginate should not be used. Caution is advised with polyether if undercuts are present.

Skeletal and Dentoalveolar Changes due to a Class II Correction with the BioBiteCorrector®: a Retrospective Radiological Study

Johanna Schmid

Orthodontics deals with diagnosis, prevention and treatment of malpositions of teeth or jaw in the stomatognathic system. Class-II-malocclusion, also called distal occlusion, represents the largest amount of dysgnathia. The BioBiteCorrector® (BBC®) is an intermaxillary non-compliance-class-II-device, screwed onto a multi-bracket appliance and causing a direct advancement of the mandible into the neutral occlusion. Developed according to the functional principle of the classic Herbst Appliance, it is made up of two triple telescopes and can be individually adjusted by using distance spacers. The aim of this retrospective study was to identify the skeletal and dentoalveolar effects of a class-II-malocclusion-treatment, using the BBC® and investigate its effectiveness, compared to the non-compliance class-II-device of Herbst. In each case, two lateral cephalometric radiographs of 36 patients were analysed by two different clinicians. The first x-ray represents the initial situation, before starting treatment with BBC®. The second one was taken after removal of the whole multi-bracket-appliance. The patients had a mean age of 14.5 years when the first x-ray was taken, they wore the BBC® 6.1 months on average. The ratio of male to female patients was 17:19. A total of sixteen parameters were used for cephalometric analysis, inter alia ANB, Wits,

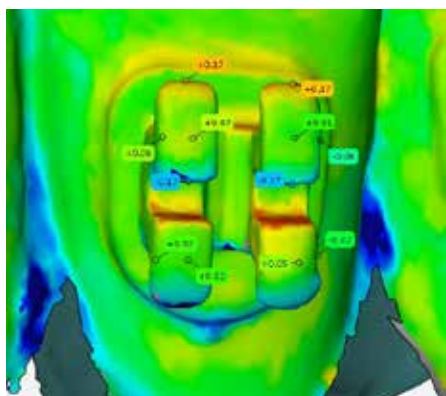

Fig. 2: Example of a bracket with discrepancies at the 12 measuring points



Fig. 3: Enamel surface quality after adhesive remnant removal: a comparative confocal microscopy study

APDI and the distance of different measuring points to the perpendicular line to the occlusal plane drawn through sella, called *Olp*: *Olp-A*, *Olp-Pog*, *Olp-Pog+Cond*, *Olp-OK1*, *Olp-UK1*. A significant change was observed both in the position of Pogonion and point A referring to *Olp*. ANB, Wits and APDI altered significantly as well as the mandible length. Referring to all observed parameters the effect of the BBC® is in the same range as the effect of the Herbst Appliance and thus the BBC® is classified as an effective and recommended method to treat a Class-II-malocclusion in growing patients.

Transfer Accuracy of two Indirect Bonding Techniques – an *In Vitro* Study with 3D Scanned Models

Johanna Schmid

Brackets are a main component in fixed orthodontic appliances as they transmit the forces on the teeth. Their correct initial placement is essential for a quick and permanent treatment success. Indirect bonding is proved to be an effective method to establish appropriate bracket positions in patients. The brackets are initially

fixed on working models. Transfer trays are then built on these models. After that, the brackets can be transferred to the patient's mouth. There are several different methods and materials for the manufacturing of these trays. The aim of this *in vitro* study was the measurement and comparison of the transfer accuracy of two different indirect bonding methods. A total of 60 plaster models (15 different models, each was grouted four times) were built and then separated into two groups of 30 models each (15 working models, 15 patient models). On these models, a total of 30 indirect bonding trays were built, thereof 15 silicone trays Bisico® S1 A+B (putty), S4 (light body) and 15 double-vacuum forms (Bioplast® 1 mm, Duran® 0.75 mm on top). With these trays, the brackets were transferred from the working models to the patients' models. The bracket positions were scanned by using an intraoral scanner (TRIOS®, 3Shape Dental Systems, Copenhagen, Denmark) before and after the indirect bonding procedure. The linear and angular discrepancies were then digitally determined by measuring six different dimensions: vertical (occlusogingival), horizontal (mesiodistal), transversal (faciolingual), tip, rotation and torque. The silicone trays show lower transfer discrepancy on average in all measured dimensions. There were obvious discrepancy tendencies for certain directions in both methods: vertical: to the occlusal direction; transversal: to the facial direction; torque: to the lingual/palatinal direction. Silicone trays have a higher precision than double-vacuum forms and should therefore be preferred for indirect bonding.

Enamel Surface Quality after Adhesive Remnant Removal: a Comparative Confocal Microscopy Study

Barbara Paal

To assess the effects of different removal variables, i.e. type of abrasive polisher, rotational speed and cooling conditions, on surface homogeneity. 120 human incisors were polished with different carbide burs (Komet Torpedo H284, Komet H22ALGK and Reliance Renew 218) and the black 3M Sof-Lex disc attached to the pop-on mandrel to remove adhesive compomer remnants. Another four teeth were left untreated and served as controls. After polishing the surfaces were scanned with a confocal microscope. The resultant surface quality was evaluated by computing the arithmetic area roughness *Sa*, the root mean square of profile deviation *Sq*, the average surface roughness *Sz*, the average smoothing depth *Sp* and the mean drag line depth *Sv*. Descrip-

tive statistics were used for data analysis. Data significance was determined with the Mann-Whitney U test. The black 3M Sof-Lex disc showed the lowest variance of *Sa*. Decreasing the speed of the Komet H22ALGK bur from 120,000 to 40,000 rpm increased the variance of *Sa*. The distribution of the root mean square of profile deviation *Sq* was similar to the *Sa* values for all abrasive instruments. The mean drag line depth *Sz* showed the widest variance for untreated teeth. The black 3M Sof-Lex discs produced the most homogeneous, the Reliance Renew 218 the roughest enamel surfaces. Of two identical burs with different shanks (Komet H22ALGK), the one with the higher speed generated smoother surfaces.

Selected Publications

Behavior of osteoblasts on TI surface with two different coating designed for orthodontic devices

Fleischmann, Leonardo, Crismani, Adriano, Falkensammer, Frank, Bantleon, Hans-Peter, Rausch-Fan, Xiaohui, Andrukho, Oleh, JOURNAL OF MATERIALS SCIENCE-MATERIALS IN MEDICINE: 2015; 26: S. 10

Stellungnahme der Österreichischen Gesellschaft für Kieferorthopädie zum Thema Allergien in der Kieferorthopädie

Wendl, B.; Crismani, A.; Bantleon, H.-P.; Kränke, B
Statement of the Austrian Orthodontic Society on the Issue of Allergies
INF ORTHOD KIEFERORTHOP: 2015; 47: S. 117-121

Betrachtung der Zahnoberfläche nach Adhäsiventfernung mit einem Konfokalmikroskop

Paal, B.; Unterberger, S. H.; Nahler, M.; Neururer, S.; Crismani, A.: Tooth Surface Appearance After Adhesive Removal Evaluation by a Confocal Microscope
INF ORTHOD KIEFERORTHOP: 2016; 48: S. 89-94

Gibt es dann noch Zahnbewegung?

Lauterbach D.
Antiphlogistika in der Kieferorthopädie
STOMATOLOGIE 2016; 03: S. 6-9

Schlafbezogene Atmungsstörungen aus zahnärztlicher Sicht
Schustereder B.
STOMATOLOGIE 2016; 03: S. 10-12

Selected Funding

- 45.000€ for Projects at the University Clinic of Orthodontics sponsored by the Austrian Society of Orthodontics

Collaborations

- Andrukho O, Competence Center Periodontal Research, Medical University of Vienna, Vienna, Austria
- Bantleon HP, Department of Orthodontics, Medical University of Vienna, Vienna, Austria
- Brenner M, Department of Orthodontics, Goethe University, Frankfurt am Main, Germany
- Proff P, Department of Orthodontics, University of Regensburg, Regensburg Germany
- Wendl B, Department of Orthodontics, Medical University of Graz, Graz, Austria
- Werbein H, Department of Orthodontics, University of Mainz, Mainz, Germany
- Förster S, Forestadent Company, Pforzheim, Germany
- Unterberger SH, Department of Material Technology, University of Innsbruck, Innsbruck, Austria

Devices and Services

- Micro-CT (University Clinic of Radiology, Innsbruck)
- Extra oral scanner Zirkonzahn S600 ARTI (University Clinic of Orthodontics, Innsbruck)
- Intraoral scanner TRIOS® (Department of Orthodontics, Goethe University, Frankfurt am Main)
- confocal microscope (Department of Material Technology, University of Innsbruck)
- CAD-program, GOM-Inspect (University Clinic of Radiology, Innsbruck)

Cranio-Maxillo-Facial and Oral Surgery



Director (till 31st of May 2017):
Univ.-Prof. DDr. Michael Rasse

Contact:
Anichstraße 35
6020 Innsbruck

Michael.Rasse@tirol-kliniken.at
Phone: +43 512 504 24373
Fax: +43 512 504 24371



Director (interim):
ao. Univ.-Prof. DDr. Wolfgang Puelacher

Contact:
Anichstraße 35
6020 Innsbruck

Wolfgang.Puelacher@i-med.ac.at
Phone: +43 512 504 24373
Fax: +43 512 504 24371
www.zmk-innsbruck.at

Research Branch (ÖSTAT Classification)

302010, 302029, 302033,
301904, 304007

Keywords

Cranio-Maxillofacial and Oral Surgery, Implants, Ultra low dose CT, Biological Surfaces, Osseointegration, Wound Healing, Tissue Engineering, Reconstructive Medicine, Nano Technology, Trauma Surgery.

Research Focus

- Reversing impaired healing of irradiated bone through the use of immobilized growth factors on nanostructured

osteosynthetic material

- Smart Implants - Monitoring of osseous healing and bone remodelling in vivo.
- VascuBone - Development of a tool box for tailor-made angio-inductive or Vascularized Bone implants
- Dose reduction (Ultra low dose CT) in CMF-Radiology (interdisciplinary clinical cooperation)

General Facts

The consequences of Radiation Therapy in Head and Neck Tumour Patients is a major focus of the Department of Cranio-Maxillo-Facial and Oral Surgery since all aspects of wound healing including cellular behaviour, blood flow and stem cell activation are influ-

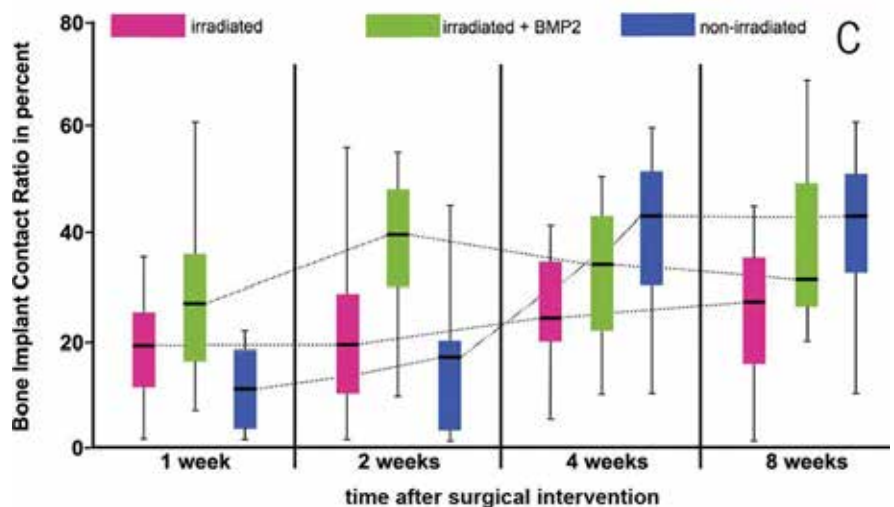
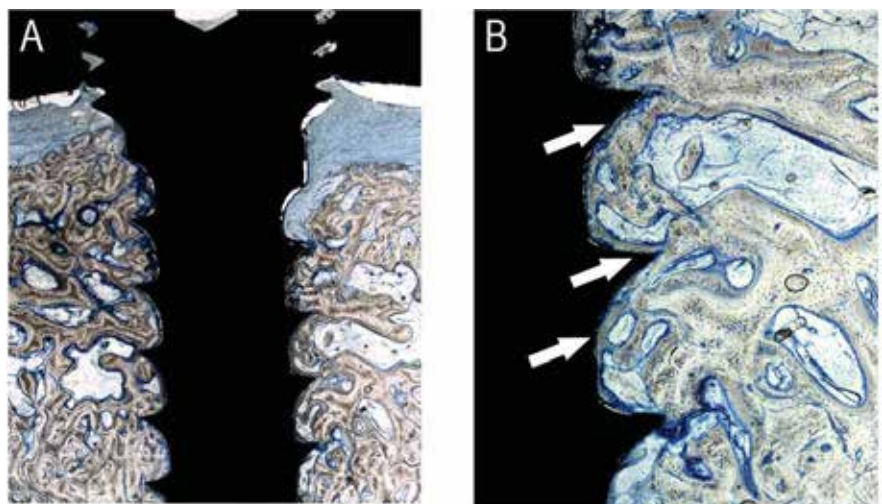

Fig. 1: Histological evaluation of the bone implant contact ratio (BICR) at the osteosynthesis screws. (A) Histological overview of the locking screw in bone subjected to toluidin blue O staining. (B) Detailed view of the osteosynthesis screw highlighting the bone contact areas (arrows). (C) BICR after 1, 2, 4, and 8 weeks of the 3 groups. BMP-2 immobilized on nano-crystalline diamond (green) resulted in an initial increase of BICR in the irradiated bone. Despite this initial increase the BICR after 8 weeks was lower compared with unirradiated bone ($p \frac{1}{4} .08$) (blue).

enced by radiation.

Using smart implants as a new sensing technology allows us to gain an insight into bone healing based on serial analysis of impedance spectroscopic examinations before radiographic or histologic changes are detectable.

Reconstructive Medicine

Reconstructive facial surgery is one focus of the Department of Cranio-Maxillofacial and Oral Surgery. After ablative tumour surgery or resection of osteonecrotic and infected bone, free tissue transplants are microvascularly anastomosed for facial rehabilitation. Research is focused on the development of minimally invasive or artificial transplants.

To achieve this goal the Department is part of the FP-7 framework project "VascuBone" together with a further 14 partners. The department is a leader in the field of preclinical trials, provides the technology for hard tissue histology and immunohistochemistry and plans and conducts animal trials.

Research

1) Bioactive Surfaces in Cranio-Maxillo-Facial and Oral Surgery

Implants have revolutionized patient care in all fields of medicine and dentistry. Titanium has evolved as the leading raw material when treatment of bone and cartilage diseases/degeneration as well as tooth loss necessitates osseointegration of individualized tissue replacement options.

This is mainly due to its bioinert properties. Titanium implants in particular provide excellent results in healthy young and adult patients. But the success rate of any implant is hampered if the implant site suffers from poor bone wound healing. Due to conditions affecting bone turnover and homeostasis such as osteoporosis, age, radiation therapy, bisphosphonate intake, infection, severe trauma or other pathology-related bone changes, osseous healing at the implant site is frequently limited. To overcome shortcomings of bone healing and osseointegration we used bioactive BMP-2 on nano-crystalline DIAMOND (NCD) coated implants based on nanotechnology and physisorption which is an approach that has been patented (Steinmueller-Nethl D, Inventors: Steinmueller-Nethl D, Steinmueller D; Bonn G, Huck C, Najam-UI-Haq M, Rainer M, Stecher G; Kloss F, Gassner R. Biological Surfaces. Patent Number: EP1824528 (Fig. 1).

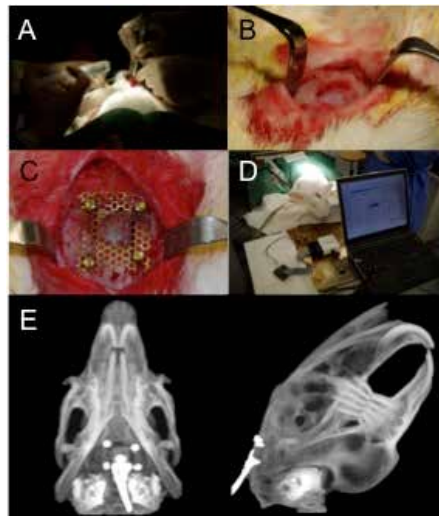

Fig. 2: Implantation of the biosensor and radiological control. (A, B) Creation of a full thickness calvarial defect; (C) Fixed biosensor; (D) Postoperative impedance measurement; (E) Radiological control of sensor position in two planes.

2) Smart Implants: Sensors as Technology Asset

Radiology remains the gold standard to show bone wound healing and osseointegration of implants despite the fact that it provides only a snap shot of the dynamic bone growth and regeneration process. Even histology provides only a glimpse of the activity or inactivity of osteoblasts, osteoclasts and osteocytes in bone.

The goal of this research was to test a novel sensing technology that is based on bioimpedance and which in due course may allow the monitoring of the osseous healing processes in an uninterrupted manner. A sub-critical size defect with full thickness was created in a rabbit calvaria that was sufficiently large to accommodate the biosensor which was mounted on a titanium mesh and inserted into the defect.

The mesh was then fixed to the adjacent bone with micro-screws. Measurements were performed every 3 or 4 days during a period of 6 weeks and spectroscopic analysis of the sensor signals were archived for later analyses. After 6 weeks the bone defects together with the biosensor was explanted and examined by means of micro-CT and histology. Serial analysis of the impedance spectroscopic examinations was performed by firstly fitting the data gathered during defect healing to a Cole-Cole equation. Thereafter the results were compiled, and the spectra thus obtained revealed gross changes in material densities during healing. Terminal analyses, by means of mi-

cro-CT as well as histology, demonstrated incomplete yet ongoing osseous healing as the defect was filled with both connective tissue as well as with newly formed bone. Furthermore, no obvious signs of inflammation were observed indicating that the implanted biosensor is biocompatible. Our results on dielectric spectroscopy may serve as a potential method for close continuous monitoring of bone wound healing in craniomaxillofacial and oral surgery in the future (Fig. 2).

3) VascuBone

The FP7 Project Vascubone deals with the development of an artificial vascularized bone transplant for the reconstruction of large facial defects. This is achieved through the use of a construct consisting of a vascular bed, modified bone replacement material and mesenchymal progenitor cells. The vascular bed is engineered by decellularizing a porcine gut segment with its supplying vascular bed and reseeding the vessels with endothelial progenitor cells from the future recipient.

Several animal experiments were performed in order to improve the common bone replacement material beta-tricalcium-phosphate. The functionality of the beta TCP surface with nanocrystalline diamonds was tested in animal models. The diamond particles by themselves modified the wettability and cell adhesion properties of the surface and were further shown to bind covalently or via physisorption different growth factors such as BMP-2 and Angiopoietin-1. The new knowledge thus acquired on functionalized biomaterials and cell behaviour led to the application of such an artificial transplant for reconstructing a mandibular continuity defect in sheep. The Horizon2020 Proposal "VascuReGenTis" has been submitted in order to test this technique in clinical trials (Fig. 3).

4) Ultralow Dose Dentomaxillofacial CT Imaging and Iterative Reconstruction Techniques

Cone Beam Computed Tomography vs Multislice Computed Tomography in Computer-Aided Design/Computer-Assisted Manufacture Guided Implant Surgery Based on Three Dimensional Optical Scanning and Stereolithographic Guides.

5) Bone Regenerating Effect of Strontium Functionalized Implant Surfaces

The functionalization of implant surfaces has gained increased attention in the last decade due to research into implant den-

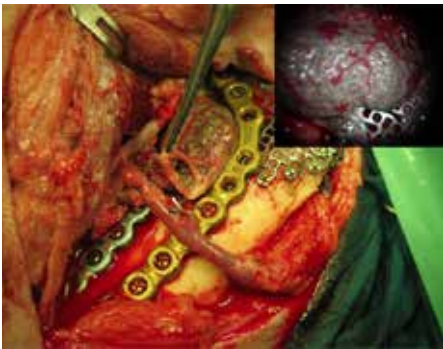

Fig. 3: Picture shows the mandibular continuity defect bridged with reconstruction plates and the microvascular anastomosed artificial transplants. The magnification shows the circulation of the transplants after anastomosis (DDr. Stigler).

tistry. A lot of different approaches directed towards enhanced bone healing have been investigated over the past couple of years and they always attempt to achieve rapid osseointegration of titanium implants. Since strontium (Sr) is known for its anabolic and anti-catabolic effects on bone, research has been focused on this alkaline earth metal and its potential impact on osseointegration.

The objective of our studies was to investigate the performance of Ti implants with a Sr functionalized titanium coating (Ti-Sr-O), which exhibits a continuous release of strontium, with respect to osseointegration. The examined Ti-Sr-O coatings, prepared from a magnetron co-sputtering process, differed from each other in coating thickness, Sr content and Sr release characteristics and the observed increase in new bone formation was found to correlate with the amount of Sr released *in vitro* (Fig. 4). The results indicate that sputtered Ti-Sr-O coatings, showing sustained release of Sr, accelerate osseointegration in healthy and osteoporotic bone plus in comparison to established surfaces and may thus have an impact on practical applications for medical implants.

Major achievements include: The production of implant surfaces with predictable Sr release properties; Verification of beneficial effects of Sr functionalized surfaces *in vivo*.

Future Goals: The evaluation of mechanical anchorage via push-out tests; Implementation of Sr functionalized implant surfaces in orthopedic and dental implantology.

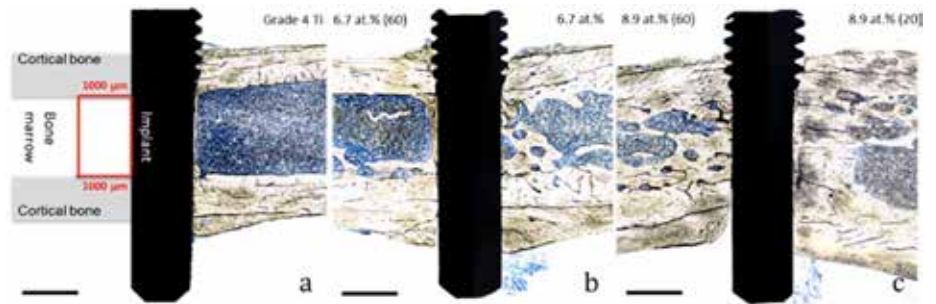

Fig. 4: Schematic illustration and histology (toluidine blue staining) of merged slides with representatives of each group. The 1500 x 1000 µm box marked scheme (a, left) indicates the standard area used to evaluate new bone formation. The area of new bone formation inside this box was measured for all samples and used to calculate the percentage of *de novo* bone synthesis with respect to the total reference area. The side of the reference box facing the implant surface was used to evaluate the percentage of direct bone-to-implant contact with respect to the total length of the reference. Minimal bone formation observed in the Grade 4 Ti (a, right). 6.7 at.% Ti-Sr-O with a 60 minute pre-wash (b, left) and no pre-wash (b right) showed increased bone formation. A higher amount of bone apposition could be observed for the 8.9 at.% Ti-Sr-O with a 60 minute pre-wash (c, left) and a 20 minute pre-wash (c, right). The implant bodies are not shown to scale as these had a diameter of 1100 µm. Scale bar is 1000 µm. Data and references cited in Offermanns et al. 2014.

Selected Publications

A domestic porcine model for studying the effects of radiation on head and neck cancers
 Arnold CR, Kloss F, Singh S, Vasiljevic D, Stigler R, Auberger T, Wenzel V, Klima G, Lukas P, Lepperding G, Gassner R.
 ORAL SURGERY ORAL MEDICINE ORAL PATHOLOGY ORAL RADIOLOGY; 2016; Epub ahead of print: S.

Ridge augmentation in an organ transplant patient
 Dalla Torre D, Burtscher D.
 INTERNATIONAL JOURNAL OF ORAL AND MAXILLOFACIAL SURGERY; 2016; 45: S. 658-661

The impact of sexual behavior on oral HPV infections in young unvaccinated adults
 Dalla Torre D, Burtscher D, Soelder E, Widschwendter A, Rasse M, Puelacher W.
 CLINICAL ORAL INVESTIGATIONS; 2016; 20: S. 1551-1557

Osteoneogenesis due to periosteal elevation with degradable and nondegradable devices in Gottingen Minipigs
 Dziewiecki D, van de Loo S, Gremse F, Kloss-Brandstätter A, Kloss F, Offermanns V, Yamauchi K, Kessler P, Lethaus B.
 JOURNAL OF CRANIO-MAXILLOFACIAL SURGERY; 2016; 44: S. 318-324

Condylar Erosion in Patients With Chronic Temporomandibular Joint Arthralgia: A Cone-Beam Computed Tomography Study
 Emshoff R, Bertram F, Schnabl D, Stigler R, Steinmaßl O, Rudisch A.
 JOURNAL OF ORAL AND MAXILLOFACIAL SURGERY; 2016; 74: S. 1343

Success Rate of Two-Piece Zirconia Implants: A Retrospective Statistical Analysis
 Jank S, Hochgatterer G.
 IMPLANT DENTISTRY; 2016; 25: S. 193-198

Pain perception during debridement of hypersensitive teeth elicited by two ultrasonic scalers
 Müller S, Huber H, Goebel G, Wimmer G, Kapferer-Seebacher I.
 CLINICAL ORAL INVESTIGATIONS; 2016; Epub ahead of print: S.

Bone regenerating effect of surface-functionalized titanium implants with sustained-release characteristics of strontium in ovariectomized rats
 Offermanns V, Andersen OZ, Riede G, Andersen IH, Almqvist KP, Sørensen S, Sillassen M, Jeppesen CS, Rasse M, Foss M, Kloss F.
 INTERNATIONAL JOURNAL OF NANOMEDICINE; 2016; 11: S. 2431-2442

How meta-analytic evidence impacts clinical decision making in oral implantology: a Delphi opinion poll
 Pommer B, Becker K, Amhart C, Fabian F, Rathe F, Stigler RG.
 CLINICAL ORAL IMPLANTS RESEARCH; 2016; 27: S. 282-287

Palatal Osseous Choristoma
 Sasaki R, Yamamoto T, Ando T.
 JOURNAL OF CRANIOFACIAL SURGERY; 2016; 27: S. E2-E4

Biofunctionalization of scaffold material with nano-colored diamond particles physisorbed with angiogenic factors enhances vessel growth after implantation
 Schimke MM, Stigler R, Wu X, Waag T, Buschmann P, Kern J, Untergasser G, Rasse M, Steinmüller-Nethl D, Krueger A, Lepperding G.
 NANOMEDICINE-NANOTECHNOLOGY BIOLOGY AND MEDICINE; 2016; 12: S. 823-833

Accuracy of a flapless protocol for computer-guided zygomatic implant placement in human cadavers: expectations and reality
 Schiroll G, Angiero F, Zangerl A, Benedicenti S, Ferrante F, Widmann G.
 INTERNATIONAL JOURNAL OF MEDICAL ROBOTICS AND COMPUTER ASSISTED SURGERY; 2016; 12: S. 102-108

Kooperation von Kieferorthopädie, Kieferchirurgie und Prothetik bei der umfassenden Rehabilitation von DysgnathiepatientInnen. Teil 1: Fallbeispiel Klasse-III-Malokklusion, Unterkiefer-Schaltlücken
 Schnabl D, Brock M, Puelacher W.
 SWISS DENTAL JOURNAL; 2016; 126: S. 1031-1046

Kooperation von Kieferorthopädie, Kieferchirurgie und Prothetik bei der umfassenden Rehabilitation von DysgnathiepatientInnen. Teil 2: Fallbeispiel Klasse-II-Malokklusion, Tiefbiss, Hypodontie
 Schnabl D, Brock M, Puelacher W.
 SWISS DENTAL JOURNAL; 2016; 126: S. 1036-1052

Shortcomings of prosthodontic rehabilitation of patients living in long-term care facilities
 Steinmassl PA, Steinmassl O, Kraus G, Dumfahrt H, Grunert I.
 JOURNAL OF ORAL REHABILITATION; 2016; 43: S. 286-290

Is Cognitive Status Related to Oral Hygiene Level and Appropriate for Determining Need for Oral Hygiene Assistance?
 Steinmassl PA, Steinmassl O, Kraus G, Dumfahrt H, Grunert I.
 JOURNAL OF PERIODONTOLOGY; 2016; 87: S. 41-47

Do CAD/CAM dentures really release less monomer than conventional dentures?
 Steinmassl PA, Wiedemair V, Huck C, Klauzner F, Steinmassl O,

Grunert I, Dumfahrt H.

CLINICAL ORAL INVESTIGATIONS: 2016; [Epub ahead of print]: S.

Moving the mandible in orthognathic surgery - A multicenter analysis

Thiele OC, Kreppel M, Bittermann G, Bonitz L, Desmedt M, Dittes C, Dörre A, Dunsche A, Eckert AW, Ehrenfeld M, Fleiner B, Frerich B, Gaggli A, Gerresen M, Gmelin L, Hammacher A, Haßfeld S, Heiland M, Hemprich A, Hidding J, Hölzle F, Howaldt HP, Iizuka T, Kater W, Klein C, Klein M, Köhnke RH, Kolk A, Kübler AC, Kübler NR, Kunkel M, Kutenberger JJ, Kreusch T, Landes C, Lehner B, Mischkowski RA, Mokros S, Neff A, Nkenke E, Palm F, Paulus GW, Piesold JU, Rasse M, Rodemer H, Rothamel D, Rustemeyer J, Sader R, Scheer M, Scheffler B, Schippers C, Schliephake H, Schmelzeisen R, Schramm A, Spitzer WJ, Stoll C, Terheyden H, Weingart D, Wiltfang J, Wolff KD, Ziegler CM, Zöller JE.

JOURNAL OF CRANIO-MAXILLOFACIAL SURGERY: 2016; 44: S. 579-583

Ultralow dose dentomaxillofacial CT imaging and iterative reconstruction techniques: variability of Hounsfield units and contrast-to-noise ratio

Widmann G, Bischel A, Stratis A, Kakar A, Bosmans H, Jacobs R, Gassner EM, Puelacher W, Pauwels R.

BRITISH JOURNAL OF RADIOLOGY: 2016; 89: S. 2015 1055

Cone Beam Computed Tomography vs Multislice Computed Tomography in Computer-Aided Design/Computer-Assisted Manufacture Guided Implant Surgery Based on Three-Dimensional Optical Scanning and Stereolithographic Guides: Does Image Modality Matter?

Widmann G, Fischer B, Berggren JP, Dennhardt A, Schullian P, Reto B, Puelacher W.

INTERNATIONAL JOURNAL OF ORAL & MAXILLOFACIAL IMPLANTS: 2016; 31: S. 527-533

A prospective multicenter study to compare the precision of posttraumatic internal orbital reconstruction with standard preformed and individualized orbital implants

Zimmerer R, Ellis E, Aniceto G, Schramm A, Wagner M, Grant M, Cornelius C, Strong E, Rana M, Chye L, Calle A, Wilde Fm Perez D, Tavassol F, Bittermann G, Mahoney N, Alamillos M, Basic J, Dittmann J, Rasse M, Gellrich N.

JOURNAL OF CRANIO-MAXILLOFACIAL SURGERY: 2016; 44: S. 1485-1497

A 7-year prospective radiographic evaluation of marginal bone level around two different implant systems: a randomized clinical trial

Burtscher D, Norer B, Torre DD, Beier U, Schubert K, Grunert I.

CLINICAL ORAL IMPLANTS RESEARCH: 2015; 26: S. 1244-1249

Surgical treatment of mandibular condyle fractures using the retromandibular anterior transparotid approach and a triangular-positioned double miniplate osteosynthesis technique: A clinical and radiological evaluation of 124 fractures

Torre DD, Burtscher D, Widmann G, Pichler A, Rasse M, Puelacher W.

JOURNAL OF CRANIO-MAXILLOFACIAL SURGERY: 2015; 43: S. 944-949

Validation of Next-Generation Sequencing of Entire Mitochondrial Genomes and the Diversity of Mitochondrial DNA Mutations in Oral Squamous Cell Carcinoma

Kloss-Brandstaetter A, Weissensteiner H, Erhart G, Schaefer G, Forer L, Schoenherr S, Pacher D, Seifarth C, Stoeckl A, Fendt L, Sottsass I, Klocker H, Huck CW, Rasse M, Kronenberg F, Kloss FR.

PLOS ONE: 2015; 10: S. e0135643

Enhanced osseointegration of endosseous implants by predictable sustained release properties of strontium

Offermanns V, Andersen OZ, Falkensammer G, Andersen IH, Almtoft KP, Sorensen S, Sillassen M, Jeppesen CS, Rasse M, Foss M, Kloss F.

JOURNAL OF BIOMEDICAL MATERIALS RESEARCH PART B-APPLIED BIOMATERIALS: 2015; 103: S. 1099-1106

Systemic impact molds mesenchymal stromal/stem cell aging

Reitinger S, Schimke M, Klepsch S, de Sneeuw S, Yani SL, Gaßner R, Ertl P, Lepperding G.

TRANSFUSION AND APHERESIS SCIENCE: 2015; 52: S. 285-289

Release and bioactivity of bone morphogenetic protein-2 are affected by scaffold binding techniques in vitro and in vivo

Suliman S, Xing Z, Wu X, Xue Y, Pedersen TO, Sun Y, Døskeland AP, Nickel J, Waag T, Lygre H, Finne-Wistrand A, Steinmüller-Nethl D, Krueger A, Mustafa K.

JOURNAL OF CONTROLLED RELEASE: 2015; 197: S. 148-157

The current state of facial prosthetics - A multicenter analysis

Thiele OC, Brom J, Dunsche A, Ehrenfeld M, Federspil P, Frerich B, Hölzle F, Klein M, Kreppel M, Kübler AC, Kübler NR, Kunkel M, Kutenberger J, Lauer G, Mayer B, Mohr C, Neff A, Rasse M, Reich RH, Reinert S, Rothamel D, Sader R, Schliephake H, Schmelzeisen R, Schramm A, Sieg P, Terheyden H, Wiltfang J, Ziegler CM, Mischkowski RA, Zöller JE.

JOURNAL OF CRANIO-MAXILLOFACIAL SURGERY: 2015; 43: S. 1038-1041

Comparison of the prevalence of human papilloma virus infection in histopathologically confirmed premalignant oral lesions and healthy oral mucosa by brush smear detection

Dalla Torre D, Burtscher D, Edlinger M, Sölder E, Widschwendter A, Rasse M, Puelacher W.

ORAL SURGERY ORAL MEDICINE ORAL PATHOLOGY ORAL RADIOLOGY: 2015; 119: S. 333-339

Ultralow-dose computed tomography imaging for surgery of midfacial and orbital fractures using ASiR and MBiR

Widmann G, Dalla Torre D, Hoermann R, Schullian P, Gassner EM, Bale R, Puelacher W.

INTERNATIONAL JOURNAL OF ORAL AND MAXILLOFACIAL SURGERY: 2015; 44: S. 441-446

Accuracy of Image-Fusion Stereolithographic Guides: Mapping CT Data with Three-Dimensional Optical Surface Scanning

Widmann G, Berggren JP, Fischer B, Pichler-Dennhardt AR, Schullian P, Bale R, Puelacher W.

CLINICAL IMPLANT DENTISTRY AND RELATED RESEARCH: 2015; 17: S. E736-E744

Ultralow-Dose CT of the Craniofacial Bone for Navigated Surgery Using Adaptive Statistical Iterative Reconstruction and Model-Based Iterative Reconstruction: 2D and 3D Image Quality

Widmann G, Schullian P, Gassner EM, Hoermann R, Bale R, Puelacher W.

AMERICAN JOURNAL OF ROENTGENOLOGY: 2015; 204: S. 563-569

Selected Funding

- "Strontium functionalized titanium implants", Danish National Advanced Technology Foundation, Frank Kloss/Vincent Offermanns
- EU project FP7-HEALTH project: VasculBone - Development of a tool box for tailor-made angio-inductive or vascularized Bone implants Medical University of Innsbruck/Robert Stigler (Frank Kloss), Robert Gassner, Michael Rasse Consortium with 15 participating institutions/universities

Collaborations

- Interdisciplinary Nanoscience Center (iNANO), Aarhus University, Denmark
- Danish Technological Institute (DTI), Aarhus, Denmark
- Danish National Advanced Technology Foundation, Copenhagen, Denmark
- Elos Medtech Pinol A/S, Gørløse, Denmark
- Department of Engineering Sciences, Applied Materials Science, University of Uppsala, Sweden
- Fraunhofer-Gesellschaft zur Förderung der angewandten Forschung e.V. Würzburg, Germany, Heike Walles
- Division of Cell Biology, Salzburg, Austria, Günter Lepperding
- DiaCoating GmbH c/o Werkstätte Wattens, 6112 Wattens, Austria, Doris Steinmüller-Nethl

Pediatrics I



**Head of Research Unit
(until March 2017)
Univ.-Prof. Dr. Gerhard Gaedicke (†)**



**Director:
Univ.-Prof. Dr. Thomas Müller**

Contact:
Anichstraße 35
6020 Innsbruck

Thomas.Mueller@i-med.ac.at
Phone: +43 512 504 23500
Fax: +43 512 504 25450
<https://kinderzentrum.tirol-kliniken.at/page.cfm?vpath=paediatrie-i>

Research Branch (ÖSTAT Classification)

301114, 301301, 302078,
202012, 202016

Keywords

molecular genetics of rare diseases, cell biology, cancer biology, drug discovery, biomarkers, inherited metabolic disorders, metabolomics, breath gas analysis, hemostasiology, diabetes in childhood (epidemiology, national diabetes registry and international registry comparison)

Research Focus

Pediatric Gastroenterology and Hepatology

The identification of gene defects causing rare gastrointestinal diseases is one of the leading and most successful research areas of our Department. In close collaboration with the Section of Cell Biology we study the functional consequences of identified gene defects in genome edited cell cultures and intestinal organoids derived from human biopsies.

Cancer Biology

Our research team investigates how cell death and metabolism in childhood malignancies is controlled by FOXO transcription factors and by Inhibitor of Apoptosis proteins (XIAP and Survivin). In a translational approach we develop strategies to target these death regulators with small compounds discovered by drug repositioning. By magnetic bioprinting and 3D additive bioprinting we develop novel cell culture models which resemble the 3D architecture of normal and malignant tissue.

Pediatric Hematology-Oncology

Our main research is focussed on optimizing therapy in treatment in childhood cancer. We focus on characteristics of cancer cells and on the underlying pathology mechanisms in cancer biology; the knowledge gained leads to the development of new clinical interventions.

Pediatric Rheumatology/Rare Diseases

The main research focus in pediatric rheumatology is development of biomarkers for autoimmune diseases in infancy and adolescence. The complement system, part of innate immunity, is rather underestimated in the pathogenesis of autoimmune diseases. The first results of our work suggest an extremely high turnover of complement in some pediatric autoimmunopathies and au-

toinflammatory diseases. The complement system might be a potential biomarker for monitoring autoimmune diseases and may herald subclinical inflammation.

Inherited Metabolic Diseases/ Rare Diseases

The main research focus of our group is the biochemical characterization of known and unknown inherited metabolic diseases, including identification of new diseases. Additionally, we have implemented methods for investigating pathophysiology and for evaluation of treatment in diagnosed patients. Inherited metabolic disorders are also part of the project for characterization of Rare and Undiagnosed Diseases.

Neuropediatric Diseases

The main research focus is the identification of new genetic causes for neurological diseases including epilepsy, rare channelopathies and neuromuscular diseases. Furthermore, we focus on acquired demyelinating syndromes in children, especially those associated with autoantibodies to myelin oligodendrocyte glycoprotein.

Pediatric Diabetes

Epidemiology: data collection on national registry basis, benchmarking and quality control between small, median and large diabetes centres in Austria and Germany. International and trans-Atlantic comparison of diabetes management in children and adolescents

Treatment: research focus on insulin pump treatment and continuous glucose monitoring, improvement of closed loop systems.

Diabetes complications: research focus on cardiovascular outcome parameters and early signs of cardiovascular complications, establishing screening methods for early detection using IMT (intima media thickness) aortic stiffness and distensibility measurements.

Genetic forms of diabetes: neonatal diabetes, hyperinsulinism in the neonate

Pediatric Critical Care Medicine

Our research focusses mainly on extracorporeal therapies in critically ill children; these include extracorporeal membrane oxygenation (ECMO), continuous renal replacement therapy (CRRT) and therapeutic plasma exchange (TPE).

General Facts

The molecular biology laboratory hosts the research teams of Assoc. Prof. Dr. Michael J. Ausserlechner (Cancer Biology) and As-



soc. Prof. Dr. Andreas Janecke (Molecular Genetics) and associate groups (Priv.Do. Dr. Jürgen Brunner (Pediatric Rheumatology) and Assoc. Prof. Dr. Roman Crazzolaro (Pediatric Hematology-Oncology) and is equipped with a Apotome live-cell imaging fluorescence microscope, luminescence and fluorescence imaging, a flow cytometer, FPLC, quantitative realtime PCR, a 3D Bioprinter, a pipetting robot for drug screening and a level 2 cell culture laboratory. The teams closely cooperate with national and international partners in Europe and Canada.

The metabolic laboratory of the Department of Pediatrics I is sustained by Assoc. Profs. Drs. Sabine Scholl-Bürgi and Daniela Karall. There is a close collaboration with other research groups within the campus, especially with the Department of Human Genetics, the Breath Gas Research Group and Division of Biological Chemistry; as well as international cooperation with mainly European Research Groups.

A team of physicians (specialized in pediatric endocrinology and diabetes) and specialized nurses (diabetes educators) are running the outpatient clinical routine service. Collaborations are established within

the Department of Pediatrics (e.g. ped. cardiology - both, for clinical collaboration as well as in scientific projects - complications screening), within the Medical University of Innsbruck (Center of blood transfusion and immunology, Institute of Medical Statistics, Informatics, and Health Economics). Strong collaborations are performed with the university based diabetes centres in Austria (Graz and Vienna - physical activity study, parietal antibody study, diabetes registry,...) and furthermore very strong collaborations are established with the German diabetes registry (DPV) and the US based diabetes registry (T1D Exchange).

Research

Molecular genetics of congenital diarrheas: In 2015 and 2016, our Research Group (Assoc. Prof. Dr. Andreas Janecke, Assoc. Prof. Dr. Thomas Müller, Assoc. Prof. Dr. Peter Heinz-Erian) identified mutations in the NHE3 and GUCY2C genes as causes of congenital sodium diarrhea.

Cancer Biology

The main research interests of the group of Assoc.Prof.Dr. M.J. Ausserlechner are the molecular function and regulation of FOXO transcription factors that control cell death,

detoxification and longevity in childhood malignancies. In cooperation with partners from Innsbruck, Padua, Prague, Frankfurt and Canada we investigate prognostic relevance, molecular function of these master regulators of cell homeostasis and identify novel drugs by pharmacophore-based virtual screening.

The second focus lies on the Inhibitor of Apoptosis Proteins XIAP and Survivin that are frequently overexpressed in childhood cancer. These proteins inhibit cell death either by directly binding caspases or by reprogramming cellular metabolism (cooperation with Exp. Neonatology, Priv.Do. Dr. Hagenbuchner at the Department of Pediatrics II). We defined how Survivin regulates mitochondrial structure and activity and promotes glycolysis in cancer cells (Warburg effect). Via fluorescence polarization screening of drug libraries we identified several repositioned drugs that efficiently interfere with the function of IAP proteins (XIAP) and sensitize cancer cells to chemotherapy-induced apoptosis in vitro and in vivo.

Inherited Metabolic Disorders/Rare diseases

The main research interests of the group of A.Univ-Prof.Dr. D. Karall and PD Dr. S.

Scholl-Bürgi are the inherited metabolic disorders propionic/methylmalonic acidemia, long-chain fatty acid oxidation disorders, and disorders of energy metabolism on the clinical, epidemiological, biochemical and molecular level. In the last years the research focussed on identification of new disorders (e.g. CoQ4, mitochondrial fission and fusion, SPENCD, PIGQ) and characterization of known disorders (e.g. LCHAD deficiency, GLUT1-deficiency syndrome, PIGA, FBXL4, ALG8-CDG).

Inherited metabolic disorders are embedded in the activities around the Center of Rare Diseases Innsbruck ("Zentrum für Seltene Krankheiten Innsbruck"), that has coordinated networking between colleagues involved in clinical and research on the campus since 2015.

Pediatric Hematology-Oncology

Studies on deletion in the 11p15.5 imprinting center region in Beckwith-Wiedemann patients and deletions of the KINDLIN-3 region in patients with osteopetrosis have contributed to knowledge about the respective diseases, pointing to possible strategies for future treatment management. In β -thalassaemia patients progress on monitoring mixed chimerism after hematopoietic stem cell transplant has been proposed as a rationale for therapy modification, improving the level of donor erythroid precursors. Finally, the report of successful hematopoietic stem cell transplants in infants with Blackfan Diamond anemia will extend the therapeutic options for patients that are otherwise compromised by life-threatening conditions and improve their clinical outcome.

Pediatric Rheumatology/Rare Diseases

We focussed on the role of the complement system in autoinflammatory diseases and provide patient data to the following international registries:

BIKER (the biological registry of the Gesellschaft für Kinder und Jugendrheumatologie), EUROFEVER (registry of PRINTO for autoinflammatory disorders)

Neuropediatric Diseases

Our research focusses on cooperations to describe rare channelopathies of neurological diseases (Ehlers Danlos, KCNQ2-, GABRG2-, GRIN2A-mutations and Ring Chromosome 18).

Dr. Matthias Baumann focusses on cooperations to describe especially Ehlers Danlos syndrome and acquired demyelinating syndromes in children (e.g. MOG-Ab associated diseases).



Diabetes Registries

Assoz. Prof. PD Dr. Sabine Hofer, member of the scientific committee of the Austrian/German Diabetes registry (DPV), is coordinating scientific research hypotheses based on data obtained from registries. Our main focus since 2013 is the international comparison of diabetes management and outcome parameters in children and adolescents of diabetes with various European countries and world wide.

Diabetes Complications Screening

Ass. Prof. PD Dr. Sabine Hofer and Univ. Prof. Dr. Daniela Baumgartner focussed on screening for complications in children with diabetes, testing and establishing an early non invasive method measuring aortic distensibility and stiffness - this work is ongoing.

Genetic Diabetes

Univ. Prof. Dr. Elisabeth Steichen and Ass. Prof. PD Dr. Sabine Hofer focussed on rare neonatal forms and manifestations of diabetes and hyperinsulinism.

Pediatric Critical Care Medicine

Dr. Gerard Cortina focussed on identification of criteria influencing outcome of critically ill children who received extracorporeal therapies such as ECMO, CRRT and TPE, both alone or in combination. These retrospective analyses were performed in collaboration with the Department of critical care of the Royal Children's Hospital in Melbourne, Australia.

Selected Publications

Molecular Genetics/Congenital Diarrhea

Biallelic IARS Mutations Cause Growth Retardation with Prenatal Onset, Intellectual Disability, Muscular Hypotonia, and Infantile Hepatopathy
Kopajtich, Robert, Murayama, Kei, Janecke, Andreas R., Haack, Tobias B., Breuer, Maximilian, Knisely, A. S., Harting, Inga, Ohashi, Toya, Okazaki, Yasushi, Watanabe, Daisaku, Tokuzawa, Yoshimi, Kotzaeridou, Urania, Koelker, Stefan, Sauer, Sven, Carl, Matthias, Straub, Simon, Entenmann, Andreas, Gizewski, Elke, Feichtinger, Rene G., Mayr, Johannes A., Lackner, Karoline, Strom, Tim M., Meitinger, Thomas, Mueller, Thomas, Ohtake, Akira, Hoffmann,

Georg F, Prokisch, Holger, Staufner, Christian, AMERICAN JOURNAL OF HUMAN GENETICS: 2016;99: S.414-422

Reduced sodium/proton exchanger NHE3 activity causes congenital sodium diarrhea

Janecke, Andreas R., Heinz-Erian, Peter, Yin, Jianyi, Petersen, Britt-Sabina, Franke, Andre, Lechner, Silvia, Fuchs, Irene, Melancon, Serge, Uhlig, Holmh H., Travis, Simon, Marinier, Evelyn, Perisic, Vojislav, Ristic, Nina, Gerner, Patrick, Booth, Ian W., Wedenoja, Satu, Baumgartner, Nadja, Vodopiutz, Julia, Frechette-Duval, Marie-Christine, De Lafolie, Jan, Persad, Rabindranath, Warner, Neil, Tse, C. Ming, Sud, Karan, Zachos, Nicholas C., Sarker, Rafiqueel, Zhu, Xinjun, Muise, Aleixo M., Zimmer, Klaus-Peter, Witt, Heiko, Zoller, Heinz, Donowitz, Mark, Mueller, Thomas, HUMAN MOLECULAR GENETICS: 2015; 24: S. 6614-6623

Early Clinical Diagnosis of PC1/3 Deficiency in a Patient With a Novel Homozygous PCSK1 Splice-Site Mutation

Haerter, Bettina, Fuchs, Irene, Mueller, Thomas, Akbulut, Ulas Emre, Cakir, Murat, Janecke, Andreas R., JOURNAL OF PEDIATRIC GASTROENTEROLOGY AND NUTRITION: 2016; 62: S. 577-580

Congenital secretory diarrhoea caused by activating germline mutations in GUCY2C

Mueller, Thomas, Rasool, Insha, Heinz-Erian, Peter, Mildnerberger, Eva, Huelstrunk, Christian, Mueller, Andreas, Michaud, Laurent, Koot, Bart G. P., Ballauff, Antje, Vodopiutz, Julia, Rospal, Stefan, Petersen, Britt-Sabina, Franke, Andre, Fuchs, Irene, Witt, Heiko, Zoller, Heinz, Janecke, Andreas R., Visweswariah, Sandhya S., GUT: 2016; 65: S. 1306-1313

Cargo-selective apical exocytosis in epithelial cells is conducted by Myo5B, Slp4a, Vamp7, and Syntaxin 3

Vogel, Georg F., Klee, Katharina M. C., Janecke, Andreas R., Mueller, Thomas, Hess, Michael W., Huber, Lukas A., JOURNAL OF CELL BIOLOGY: 2015; 211: S. 587-604

Cancer Biology

Nuclear FOXO3 predicts adverse clinical outcome and promotes tumor angiogenesis in neuroblastoma

Hagenbuchner, Judith, Rupp, Martina, Salvador, Christina, Meister, Bernhard, Kiechl-Kohlendorfer, Ursula, Müller, Thomas, Geiger, Kathrin, Sergi, Consolato, Obexer, Petra, Ausserlechner, Michael J., ONCOTARGET: 2016; 7: S. 77591-77606

BIRC5/Survivin as a target for glycolysis inhibition in high-stage neuroblastoma

Hagenbuchner, J., Kiechl-Kohlendorfer, U., Obexer, P., Ausserlechner, M. J., ONCOGENE: 2016; 35: S. 2052-2061

Targeting transcription factors by small compounds-Current strategies and future implications

Hagenbuchner, Judith, Ausserlechner, Michael J., BIOCHEMICAL PHARMACOLOGY: 2016; 107: S. 1-13

Mitochondrial survivin - an Achilles' heel in cancer chemoresistance

Ausserlechner, Michael J., Hagenbuchner, Judith, MOLECULAR & CELLULAR ONCOLOGY: 2016; 3: S. e1076589

Pediatric Hematology-Oncology

Successful management of mixed chimerism after bone marrow transplant in beta-thalassemia major

Kropshofer, Gabriele, Sopper, Sieghart, Steurer, Michael, Schwinger, Wolfgang, Crazzolaro, Roman, AMERICAN JOURNAL OF HEMATOLOGY: 2016; 91: S. E357-E358

A new mutation in the KINDLIN-3 gene ablates integrin-dependent leukocyte, platelet, and osteoclast function in a patient with leukocyte adhesion deficiency-III

Crazzolaro, Roman, Maurer, Kathrin, Schulze, Harald, Zieger, Barbara, Zustin, Jozef, Schulz, Ansgar S.,
PEDIATRIC BLOOD & CANCER: 2015; 62: S. 1677-1679

Pediatric Hemostasiology

Ex vivo reversal of effects of rivaroxaban evaluated using thromboelastometry and thrombin generation assay

Schenk, B., Wuertinger, P., Streif, W., Sturm, W., Fries, D., Bachler, M.,
BRITISH JOURNAL OF ANAESTHESIA: 2016; 117: S. 583-591

Predicting Transfusion Requirements During Extracorporeal Membrane Oxygenation

Tauber, Helmut, Streif, Werner, Fritz, Josef, Ott, Helmut, Weigel, Guenter, Loacker, Lorin, Heinz, Anneliese, Velik-Salchner, Corinna,
JOURNAL OF CARDIOTHORACIC AND VASCULAR ANESTHESIA: 2016; 30: S. 692-701

Biopsychology: A Method Using Live Tissue Staining to Image Cell Function in the Kidney

Ashraf, Muhammad Imtiaz, Fries, Dietmar, Streif, Werner, Aigner, Felix, Hengster, Paul, Troppmair, Jakob, Hermann, Martin,
METHODS IN MOLECULAR BIOLOGY: 2016; 1397: S. 81-90

Pediatric Rheumatology

Tick-borne encephalitis in a child with previous history of completed primary vaccination

Zlmy, Manuela, Haberlandt, Edda, Brunner, Juergen, Dozcy, Ludwig, Rostasy, Kevin,
PEDIATRICS INTERNATIONAL: 2016; 58: S. 56-58

A novel therapeutic approach for LPIN1 mutation-associated rhabdomyolysis: The Austrian experience

Pichler, Karin, Scholl-Buergi, Sabine, Birnbacher, Robert, Freilinger, Michael, Straub, Simon, Brunner, Juergen, Zschocke, Johannes, Bittner, Reginald E., Karall, Daniela,
MUSCLE & NERVE: 2015; 52: S. 437-439

Feasibility of Ultrasound-Guided Sacroiliac Joint Injections in Children Presenting with Sacroiliitis

Klauser, A. S., Sailer-Hoek, M., Abdellah, M. M. H., Taljanovic, M. S., Siedentopf, C., Auer, T., Brunner, J., Jaschke, W. R.,
ULTRASCHALL IN DER MEDIZIN: 2016; 37: S. 389-394

Inherited Metabolic Disorders

Clinical outcome, biochemical and therapeutic follow-up in 14 Austrian patients with Long-Chain 3-Hydroxy Acyl CoA Dehydrogenase Deficiency (LCHADD)

Karall, Daniela, Brunner-Krainz, Michaela, Kogelnig, Katharina, Konstantopoulou, Vassiliki, Maier, Esther M., Moeslinger, Dorothea, Plecko, Barbara, Sperl, Wolfgang, Volkmar, Barbara, Scholl-Buergi, Sabine,
ORPHANET JOURNAL OF RARE DISEASES: 2015; 10: S. 21

COQ4 Mutations Cause a Broad Spectrum of Mitochondrial Disorders Associated with CoQ(10) Deficiency

Brea-Calvo, Gloria, Haack, Tobias B., Karall, Daniela, Ohtake, Akira, Invernizzi, Federica, Carrozzo, Rosalba, Kremer, Laura, Dusi, Sabrina, Fauth, Christine, Scholl-Buergi, Sabine, Graf, Elisabeth, Ahting, Uwe, Resta, Nicoletta, Laforgia, Nicola, Verrigni, Daniela, Okazaki, Yasushi, Kohda, Masakazu, Martinelli, Diego, Freisinger, Peter, Strom, Tim M., Meitinger, Thomas, Lamperti, Costanza, Lacson, Atilano, Navas, Placido, Mayr, Johannes A., Bertini, Enrico, Murayama, Kei, Zeviani, Massimo, Prokisch, Holger, Ghezzi, Daniele,
AMERICAN JOURNAL OF HUMAN GENETICS: 2015; 96: S. 309-317

Ketogenic diets in patients with inherited metabolic disorders

Scholl-Buergi, S., Hoeller, A., Pichler, K., Michel, M., Haberlandt, E., Karall, D.,
JOURNAL OF INHERITED METABOLIC DISEASE: 2015; 38: S. 765-773

Clinical phenotype, biochemical profile, and treatment in 19 patients with arginase 1 deficiency

Huemer, Martina, Carvalho, Daniel R., Brum, Jaime M., Unal, Ozlem, Coskun, Turgay, Weisfeld-Adams, James D., Schrager, Nina L., Scholl-Buergi, Sabine, Schlune, Andrea, Donner, Markus G., Hersberger, Martin, Gempeler, Claudio, Riesner, Brunhilde, Ulmer, Hanno, Haeblerle, Johannes, Karall, Daniela,
JOURNAL OF INHERITED METABOLIC DISEASE: 2016; 39: S. 331-340

Pediatric and Adolescent Diabetes

Obesity in Youth with Type 1 Diabetes in Germany, Austria, and the United States

DuBose, Stephanie N., Hermann, Julia M., Tamborlane, William V., Beck, Roy W., Dost, Axel, DiMeglio, Linda A., Schwab, Karl, Otfried, Holl, Reinhard W., Hofer, Sabine E., Maahs, David M., Type 1 Diabet Exchange Clinic,
JOURNAL OF PEDIATRICS: 2015; 167: S. 627-+

Structural Analysis of Treatment Cycles Representing Transitions between Nursing Organizational Units Inferred from Diabetes

Dehmer, Matthias, Kurt, Zeyneb, Emmert-Streib, Frank, Them, Christa, Schulz, Eva, Hofer, Sabine,
PLOS ONE: 2015; 10: S. e0127152

Increased DNA methylation variability in type 1 diabetes across three immune effector cell types

Paul, Dirk S., Teschendorff, Andrew E., Dang, Mary A. N., Lowe, Robert, Hawa, Mohammed I., Ecker, Simone, Beyan, Huriya, Cunningham, Stephanie, Fouts, Alexandra R., Ramelius, Anita, Burden, Frances, Farrow, Samantha, Rowston, Sophia, Rehnstrom, Karola, Frontini, Mattia, Downes, Kate, Busche, Stephan, Cheung, Warren A., Ge, Bing, Simon, Marie-Michelle, Bujold, David, Kwan, Tony, Bourque, Guillaume, Datta, Avik, Lowy, Ernesto, Clarke, Laura, Flicek, Paul, Libertini, Emanuele, Heath, Simon, Gut, Marta, Gut, Ivo G., Ouwehand, Willem H., Pastinen, Tomi, Soranzo, Nicole, Hofer, Sabine E., Karges, Beate, Meissner, Thomas, Boehm, Bernhard O., Cilio, Corrado, Larsson, Helena, Elding-Lernmark, Ake, Steck, Andrea K., Rakyan, Vardhman K., Beck, Stephan, Leslie, R. David,
NATURE COMMUNICATIONS: 2016; 7: S. 13555

International Comparison of Smoking and Metabolic Control in Patients With Type 1 Diabetes

Hofer, Sabine E., Miller, Kellee, Hermann, Julia M., DeSalvo, Daniel J., Riedl, Michaela, Hirsch, Irl B., Karges, Wolfram, Beck, Roy W., Holl, Reinhard W., Maahs, David M., DPV Initiative, T1D Exchange Clinic Network,
DIABETES CARE: 2016; 39: S. E177-E178

Pediatric Critical Care Medicine

De novo tacrolimus-induced thrombotic microangiopathy in the early stage after renal transplantation successfully treated with conversion to everolimus

Cortina, Gerard, Trojer, Raphaela, Waldegger, Siegfried, Schneeberger, Stefan, Gut, Nadezda, Hofer, Johannes,
PEDIATRIC NEPHROLOGY: 2015; 30: S. 693-697

Clonidine as a First-Line Sedative Agent After Neonatal Cardiac Surgery: Retrospective Cohort Study

Kleiber, Niina, de Wildt, Saskia N., Cortina, Gerard, Clifford, Michael, Ducruet, Thierry, Tibboel, Dick, Millar, Johnny,
PEDIATRIC CRITICAL CARE MEDICINE: 2016; 17: S. 332-341

Pediatric Neurology

Clinical and neuroradiological differences of paediatric acute disseminating encephalomyelitis with and without antibodies to the myelin oligodendrocyte glycoprotein

Baumann, M., Sahin, K., Lechner, C., Hennes, E. M., Schanda, K., Mader, S., Karenfort, M., Selch, C., Haeusler, M., Eisenkoelbl, A., Salandin, M., Gruber-Sedlmayr, U., Blaschek, A., Kraus, V., Leiz, S., Finsterwalder, J., Gotwald, T., Kuchukhidze, G., Berger, T., Reindl, M., Rostasy, K.,
JOURNAL OF NEUROLOGY NEUROSURGERY AND PSYCHIATRY: 2015; 86: S. 265-272

Children with multiphasic disseminated encephalomyelitis and antibodies to the myelin oligodendrocyte glycoprotein (MOG): Extending the spectrum of MOG antibody positive diseases

Baumann, Matthias, Hennes, Eva-Maria, Schanda, Kathrin, Karenfort, Michael, Kornek, Barbara, Seidl, Rainer, Diepold, Katharina, Lauffer, Heinz, Marquardt, Iris, Strautmanis, Jurgis, Syrbe, Steffen, Vieker, Silvia, Hoeffberger, Romana, Reindl, Markus, Rostasy, Kevin,
MULTIPLE SCLEROSIS JOURNAL: 2016; 22: S. 1821-1829

Selected Funding

- "Mutations in primary intestinal lymphangiectasia", ÖNB Nr. 16678 Thomas Müller, 2016 (total: 150.000 €)
- „Hemmung der FOXO3-DNA Interaktion durch kleinmolekulare Inhibitoren“, FWF Joint International Project (Austria - Czech Republic), M.J. Ausserlechner (total: 586.955 €)
- Horizon 2020 call for Project (KidsAP) for the next 4 years (2017-2020) (total: 400.000 €)

Collaborations

- Prof. Dr. Tomas Obsil, Biophysical Chemistry, Charles University, Prague, Czech Republic
- Dr. Veronica Obsilova, Institute of Physiology, Academy of Sciences, Prague, Czech Rep.
- Prof. Dr. Jan Vesely, Organic Chemistry, Charles University Prague, Czech Republic
- Prof. Dr. Consolato Sergi, Institute of Pathology, University of Alberta, Edmonton, Canada
- Dr. Giampietro Viola, Department of Woman's and Child's Health, Oncohematology laboratory, University of Padova, Italy
- Prof. Dr. Franz Rödel, Department of Radiotherapy and Oncology, Goethe-University, Frankfurt am Main, Germany
- Prof. Dr. Ralf Rieker, Institut of Pathology, University of Erlangen, Germany
- Prof. Dr. Allan Kasik, Department of Pharmacology, University of Tartu, Estonia
- Prof. Dr. Gerhard Wolber, Institute of Pharmaceutical Chemistry, FU-Berlin, Germany
- Prof. Dr. Judith Rollinger, Pharmakognosie/Pharmazeutische Biologie, Universität Wien
- Dr. Suse Benseler, Childhood Arthritis and Rheumatology Research Alliance (CARRA), Pediatric Rheumatology European Society: BRAIN WORKS; Toronto, Canada
- Prof. Dr. Hans Clevers, Hubrecht Institute, Utrecht, The Netherlands
- Prof. Marco Gattorno, Istituto Gaslini, University of Genova, Italy.
- Prof. Zoltan Prohaska of Immunology, Semmelweis University, 3rd Department of Medicine, Research Laboratory, Budapest, Hungary
- Prof. Dr. Dirk Foell, Münster; Klinik für Pädiatrische Rheumatologie und Immunologie, Münster, Germany
- Prof. Peter Haas, Deutsches Zentrum für Kinder- und Jugendrheumatologie, Garmisch-Partenkirchen, Germany
- Prof. Dr. Wolfgang Sperl, Assoc. Prof. Dr. Johannes A. Mayr, Mitocenter, University Children's Hospital Salzburg
- Prof. Dr. Holger Prokisch, mitoNET (Network for diagnosis and therapy in mitochondrial diseases), Helmholtz Institute, München, Germany
- Prof. Dr. Stefan Kölker, EIMD (European Network for Intoxication Type Metabolic Disorders), Medical University of Heidelberg, Germany
- Assoc. Prof. Dr. Martina Huemer, EHOD (European Network for Homocystinurias and Remethylation Defects), University Children's Hospital Zürich, Switzerland
- Prof. Dr. Thomas Orladen, iNTD (International Neurotransmitter Disease Network), Medical University of Heidelberg, Germany
- Prof. Dr. Matthias R. Baumgartner, MMA-PA (methylmalonic and propionic acidemias) guideline group, University Children's Hospital Zürich, Switzerland
- Prof. Dr. Johannes Häberle, UCD (urea cycle disorders) guideline group, University Children's Hospital Zürich, Switzerland
- Prof. Dr. Ron Wevers, Dr. Dirk J. Lefeber, University Children's Hospital Nijmegen, The Netherlands
- Assoc. Prof. Dr. Dorothea Möslinger, for the Austrian Metabolic Group, University Children's Hospital Vienna
- Prof. Dr. M. Feucht, University Children's Hospital Vienna, Austria.
- PD. Dr. T. Bast, Epilepsiezentrum Kork, Kehl-Kork Germany.
- PD Dr. G. Kluger, University Hospital Salzburg, Austria.
- Prof. Dr. J. Hardwick, John Hopkins Medicine, University Baltimore, USA, Pharmacology and Molecular Sciences.
- PD Dr. Peter Bursiaki, Pädiatrie Wuppertal, Universitätsklinik Köln
- Univ. Prof. Birgit Rami, Department of Pediatrics, Medical University of Vienna, Austria
- PD Dr. Elke Fröhlich-Reiterer, Department of Pediatrics, Medical University of Graz, Austria
- Prof. Reinhard Holl, Institute of Epidemiology and medical Biometry, University of Ulm, Germany
- PD Dr. Klemens Raile, Department of Pediatrics, Virchow Clinic, Charité Berlin, Germany
- Prof. Dr. Sian Ellard, Division of Human Genetics, University of Southampton, U.K.
- Prof. Dr. Justin T Warner, Children's Hospital for Wales, Cardiff, U.K. on behalf of the National Diabetes audit and the Royal College of Paediatrics and Child Health
- Prof. Dr. Kim Donaghy and Prof. Maria Craig, Department of Pediatrics, Childrens Hospital at Westmead, University of Sydney, Australia
- Prof. Dr. Gerd Horneff, Asklepios Kliniken St. Augustin, BIKE: Biological registry, Germany
- Prof. Dr. Warwick Butt, Department of critical care medicine, The Royal Children's Hospital, Melbourne, Australia
- PD Dr. Marianne Rohrbach, University Children's Hospital Zürich, Switzerland
- Dr. Cecilia Giunta, University Children's Hospital Zürich, Switzerland

Pediatrics II



Director:
Univ.-Prof.ⁱⁿ Dr.ⁱⁿ Ursula
Kiechl-Kohlendorfer

Contact:
Anichstraße 35
6020 Innsbruck

Ursula.Kohlendorfer@i-med.ac.at
Phone: +43 512 504 27307
Fax: +43 512 504 27308
<https://kinderzentrum.tirol-kliniken.at/page.cfm?vpath=paediatric-ii>

Research Branch (ÖSTAT Classification)

302049, 301401, 302060

Keywords

preterm infants, neonatal neuroscience, developmental outcome, cardiovascular risk, sudden infant death syndrome, neuroprotection, sigma-1 receptor ligands, mitochondrial metabolism, FOXO3, apoptosis

Research Focus

- Characterization of risk predictors for adverse outcome of preterm infants
- Monitoring of the preterm brain (aEEG, MRI)
- Investigation of effects of prematurity, neonatal growth and feeding practices (focus on human milk) on cardiovascular risk factors and neurodevelopmental outcome
- Development of substances for neuroprotection and treatment of perinatal brain injury
- Role of anti-apoptotic substances in mitochondrial metabolism
- Impact of FOXO3 on cell death and stress resistance in neuronal cells

General Facts

The Department of Neonatology at the Medical University of Innsbruck is a perinatal centre with the highest level of care. It offers care for all very preterm and critically ill neonates in Tyrol and offers a standardized follow-up programme until these children reach school-age. Researchers in the Department of Neonatology focus on both clinical and basic science (www.neonatal-research.at) with the aim of improving the survival and long-term outcome of neonates. Clinical research includes the characterization of neurodevelopmental and cardiovascular outcome of very preterm infants until school-age and the definition of risk predictors for adverse outcome.

This encompasses multimodal monitoring of the neonatal brain (aEEG, MRI), the evaluation of the role of nutrition/growth and research on the optimization of perinatal resuscitation. The department also focuses on risk factors for and prevention of sudden infant death syndrome (SIDS).

The basic research programme is dedicated to identifying mechanisms of neuroprotection in perinatal brain injury models and aims at assessing new therapeutic strategies. In addition, the department participates in a world-wide quality improvement collaboration - the Vermont Oxford network - with the aim of following key neonatal outcomes and thereby continuously improving patient care. There are close national and international collaborations with other perinatal centres and with the local neuroscience and cardiovascular science group.

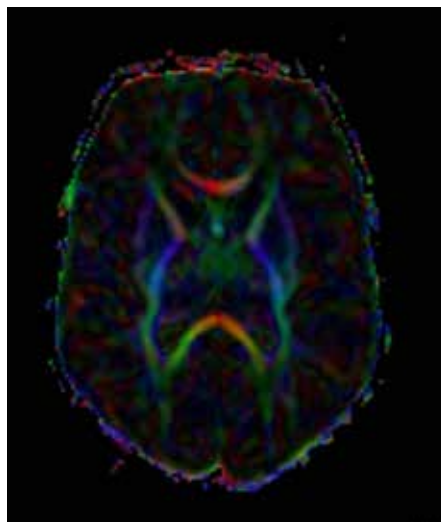

Fig. 1: Diffusion tensor imaging of a preterm-born infant at 40 weeks of gestation

Research

Neonatal Neuroscience - Clinical and Experimental Research Groups

Elke Griesmaier, Vera Neubauer, Anna Posod, Karina Wegleiter, Karina Wechselberger, Marlene Biermayr, Ulrike Pupp Peglow, Ursula Kiechl-Kohlendorfer
Neonatal brain injury is a major cause of infant mortality and morbidity and thus a problem of great global and national concern. In industrialized Western countries, the most common cause of neonatal brain injury is prematurity. During the last years, improvements in neonatal intensive care medicine have decreased preterm infant mortality. However, infants born prematurely remain at high risk of neurodevelopmental delay and lifelong handicap. To date, causal therapeutic strategies for neonatal brain injury are not available. Clinical management is based on an optimization of perinatal care and supportive measurements and on identifying infants at high risk for adverse neonatal outcome.

Clinical Research Projects

Evaluation of Preterm Brain

Development and Outcome Prediction

For the preterm infant, the provision of diagnostic measurements of brain compromise is of high priority in order to minimize the risk of developmental impairment. Reliable tools for early prediction of outcome are needed in order to provide the best care and support available. Amplitude integrated electroencephalography (aEEG) is used to monitor the functional status of the brain and to observe maturational changes during extrauterine development.

Magnetic resonance imaging (MRI) gives detailed information about brain development, cortical folding and myelination (Fig. 1). General movements (GM) are part of the spontaneous movement repertoire of newborn infants. The presence of GM, quality and intensity are a marker of central nervous system integrity. Our group investigates the value of these three methods (aEEG, GM and MRI) to predict neurological outcome in preterm infants.

Neurodevelopmental Follow-Up of Very Preterm Infants

Children born preterm are at risk for neurodevelopmental delay or disorder. Therefore, regular follow-up visits are important not only to provide support for these children and their parents but also for research purposes and quality control of neonatal intensive care.

Experimental Research Projects

Biomarkers of Perinatal Brain Injury

Perinatal asphyxia is one of the leading causes of neonatal deaths worldwide. Up to one third of asphyxiated newborns suffer from neonatal encephalopathy with substantial long-term morbidity. In order to improve prognosis, early identification of children at risk for neurodevelopmental impairment and timely initiation of supportive treatments are crucial. Our research group is dedicated to the assessment of both diagnostic and prognostic biomarkers of neonatal encephalopathy, with a particular focus on parameters which can be easily measured in umbilical cord or patient blood and where determination requires only small sample volumes. Promising biomarkers currently being investigated are the neuropeptide secretoneurin as well as short non-coding ribonucleic acids, so-called microRNAs. A main aim is to link basic research with clinical routine and decision making and to provide tools which help caretakers tailor therapeutic approaches.

Neuroprotective Agents

Our research group is also dedicated to the evaluation of readily available, cost-effective agents with neuroprotective potential. We use both *in vitro* (neuronal and glial cell lines, primary cell cultures) and *in vivo* model systems (rodent pups) and apply well-established injury models of neonatal brain injury (oxygen-glucose deprivation/hypoxia-ischemia, excitotoxicity (Fig.2), hyperoxia). Our main research foci are hematopoietic growth factors, neuropeptides, exogenous and endogenous sigma-1 receptor agonists as well as substances already being used in neonatal/pediatric intensive care units with different indications (e.g. sedative agents, anticonvulsants).

Cardiovascular Science

Cardiovascular Follow-Up of Very Preterm Infants

Anna Posod, Irena Odri Komazec, Ursula Kiechl-Kohlendorfer

An increasing body of evidence suggests that prematurity is associated with an adverse cardiovascular risk profile in adolescent and adult life. As early detection of cardiovascular risk indicators is crucial in order to implement effective prevention programs, our research group assesses both traditional and novel cardiovascular risk factors already at a preschool age. Methods used include anthropometry (e.g. body mass index, waist-to-hip ratio), device-based non-invasive measurements (blood pressure readings, aortic intima-me-

dia thickness measurements, echocardiography) as well as fasting blood sampling (glucose metabolism, lipid status, adipocytokines, amino acid analyses and derived indices, hormone status).

Early Vascular Ageing (EVA)

Anna Schmid, Anna Katharina Stock, Nina Gande, Ursula Kiechl-Kohlendorfer
EVA aims at improving vascular health of 15/16-year-old Tyrolean pupils and apprentices, and at elucidating mechanisms of early vascular ageing. Specifically, potential effects of dietary habits and sedentary behaviors as well as prematurity, neonatal growth characteristics and feeding practices on early vascular abnormalities, body mass index and risk factor levels are tested.

Further Experimental Research Groups

Neuronal Metabolism

Judith Hagenbuchner

Mitochondria are at the centre of cellular pathways such as oxidative phosphorylation (ATP generation), the TCA cycle, glucose metabolism and oxidation of fatty acids. Therefore alterations of mitochondrial metabolism, as for example by oxidative stress, can contribute to cell death as well as to prevention of cell death. We recently identified the protein BIRC5/survivin as an essential regulator of neuronal metabolism that affects mitochondrial fusion/fission dynamics, which protects neuronal cells as well as neuronal tumor cells from cell death by shifting cells into aerobic glycolysis. Based on these findings we are currently screening/developing small-compounds which modulate mitochondrial metabolism and the metabolism of neuronal cells to mimic the effect of survivin.

Impact of FOXO3 on Cell Death and Stress Resistance in Neuronal Cells

Petra Obexer

The pathophysiology of preterm brain damage is multifactorial and phases of hypoxia and ischemia are known to play an important role. Since FOXO transcription factors are activated by different cellular stresses and are important regulators of apoptosis as well as longevity, the research team investigates the impact of FOXO3 on cell death regulation, autophagy induction and stress resistance in neuronal cells. Our group identified C10orf10/DEPP as a direct transcriptional target of FOXO3 which localizes to peroxisomes and mitochondria, impairs cellular reactive oxygen species detoxification and thereby mediates autophagy in neuronal cells. The research team focusses further on the identification

and characterization of FOXO3-interacting drugs that inhibit the function of FOXO3 in neuronal cells.

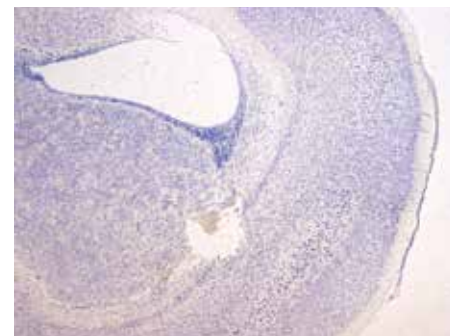

Fig.2: Histological lesion in an animal model of neonatal excitotoxic brain injury (5x magnification, light microscopy, cresyl violet staining)

Selected Publications

Aortic Elastic Properties in Preschool Children Born Preterm
Komazec, Irena Odri, Posod, Anna, Schwienbacher, Martin, Resch, Maria, Peglow, Ulrike Pupp, Kiechl, Stefan, Baumgartner, Daniela, Kiechl-Kohlendorfer, Ursula,
ARTERIOSCLEROSIS THROMBOSIS AND VASCULAR BIOLOGY: 2016; 36: S. 2268-+

Former Very Preterm Infants Show an Unfavorable Cardiovascular Risk Profile at a Preschool Age
Posod, Anna, Komazec, Irena Odri, Kager, Katrin, Peglow, Ulrike Pupp, Griesmaier, Elke, Schermer, Elisabeth, Wuertinger, Philipp, Baumgartner, Daniela, Kiechl-Kohlendorfer, Ursula,
PLOS ONE: 2016; 11: S. e0168162

Secretoneurin Serum Levels in Healthy Term Neonates and Neonates with Hypoxic-Ischaemic Encephalopathy
Wechselberger, Karina, Schmid, Anna, Posod, Anna, Hoeck, Michaela, Neubauer, Vera, Fischer-Colbrie, Reiner, Kiechl-Kohlendorfer, Ursula, Griesmaier, Elke,
NEONATOLOGY: 2016; 110: S. 14-20

Bronchopulmonary Dysplasia Is Associated with Delayed Structural Brain Maturation in Preterm Infants
Neubauer, Vera, Junker, Daniel, Griesmaier, Elke, Schocke, Michael, Kiechl-Kohlendorfer, Ursula,
NEONATOLOGY: 2015; 107: S. 179-184

BIRC5/Survivin as a target for glycolysis inhibition in high-stage neuroblastoma
Hagenbuchner, J., Kiechl-Kohlendorfer, U., Obexer, P., Ausserlechner, M. J.,
ONCOGENE: 2016; 35: S. 2052-2061

Selected Funding

Early vascular ageing (EVA), part of the excellence initiative (Competence Centers for Excellent Technologies - COMET) of the Austrian Research Promotion Agency FFG: "Research Center of Excellence in Vascular Ageing - Tyrol, VAScAge" (K-Project Nr. 843536) funded by the BMVIT, BMWFW, the Wirtschaftsagentur Wien and the Standortagentur Tirol; 1,1 Mio. Euro

Collaborations

- Lena Hellström-Westas, Department of Women's and Children's Health, University of Uppsala, Sweden
- Christiane Richter-Landsberg, Carl von Ossietzky University, Oldenburg, Germany
- Jan Lewerenz, Department of Neurology, University Hospital Ulm, Germany
- Martin Lee, Proalcta Bioscience, Monrovia, CA
- Moon R, Goldberg Center for Community Pediatric Health, Children's National Medical Center, Washington, US, and Blair PS, University of Bristol, UK (International Society for the Prevention of Infant Death)
- Consolato Sergi, Institute of Pathology, University of Alberta, Edmonton, Canada
- NCD Risk Factor Collaboration - Imperial College London

Nuclear Medicine



Director:
Univ.-Prof.ⁱⁿ Dr.ⁱⁿ Irene J. Virgolini

Contact:
Anichstraße 35
6020 Innsbruck

nuklearmedizin@i-med.ac.at
Phone: +43 512 504 22651
Fax: +43 512 504 22659
www.nuklearmedizin-innsbruck.com

Research Branch (ÖSTAT Classification)

302054, 301904, 301206

Keywords

Peptide receptor radionuclide therapy, peptide ligand radionuclide therapy, radioiodine refractory thyroid cancer, hormone refractory prostate cancer, neuroendocrine tumours

Research Focus

The Department of Nuclear Medicine is best known for its work with radiolabelled peptides, both for diagnostic and therapeutic purposes, a theme that we have systematically explored over the last two decades. We develop a variety of radiopharmaceuticals for different targets in clinical use. Our goal is to engineer more effective ligands/peptides/antibodies - "theranostics" - for individualised treatment.

General Facts

The Department of Nuclear Medicine accelerates translation of preclinical radiopharmaceutical research development (focus on radiolabelled peptides) into clinical ap-

plications towards imaging of biomarkers used for cancer treatment (70% of clinical routine), treatment of neurological impairment (20% of clinical routine) or cardiac disease (10% of clinical routine). The structure of the Department of Nuclear Medicine is based on a very creative, high quality productive, well-funded and internationally respected preclinical Research & Development Unit. This group consists of several radiochemists/pharmacists, medical physicists and PhD students. Their work results in the construction of radiotracers using different modal systems, including a variety of radiolabelled peptide analogues such as for somatostatin, vasoactive intestinal peptide (VIP), CCK-2/gastrin, or prostate-specific membrane antigen (PSMA) ligand for specific tumour targeting. Other important developments are based on Arg-Gly-Asp (RGD) peptides for imaging of angiogenesis in tumour lesions, or on hepatic binding protein for functional liver reserve estimation. Radiopharmaceuticals are produced at clinical grade in our dedicated laboratories for use in SPECT/CT or PET/CT studies. About 20 whole body PET/CT studies are performed daily in our PET Center. Patients previously evaluated by dosimetry following SPECT/CT studies are treated at our Nuclear Medicine Therapy ward with high dose theranostics. Radioiodine ablation therapy of thyroid cancer remnants, peptide receptor radionuclide therapy (PRRT) of neuroendocrine tumour patients and peptide ligand radionuclide

therapy (PLRT) of prostate cancer patients are our most important therapy tools.

Research

Preclinical Research Activities – Research & Development Unit

The research activities are focussed on preclinical research dedicated to the optimisation and improvement of radiolabelling procedures for established radiopharmaceuticals, the in-house preparation of new radiopharmaceuticals for clinical studies, as well as the preclinical development of new radioligands for molecular imaging and therapeutic purposes. Different research projects illustrate the activities in this field. The FWF project P25899-B23 "Novel ⁶⁸Ga/⁸⁹Zr-chelators for targeted biomolecules in PET (project leader: Prof. Clemens Decristoforo, PhD Dominik Summer) explores a novel scaffold to prepare highly-specific radiolabelled biomolecules for PET for radiolabelling with Ga-68 and Zr-89. Based on Fusarinine C (FSC), strategies were developed to prepare multimeric and multifunctional ligands for targeted molecular imaging especially for oncological applications. Different FSC conjugates with RGD peptide, minigastrin and affibodies were prepared showing excellent tumour targeting properties in tumour models and have already been published in high-ranking journals. Combining radiolabelling with optical signalling allows combination of imaging techniques for a variety of applica-

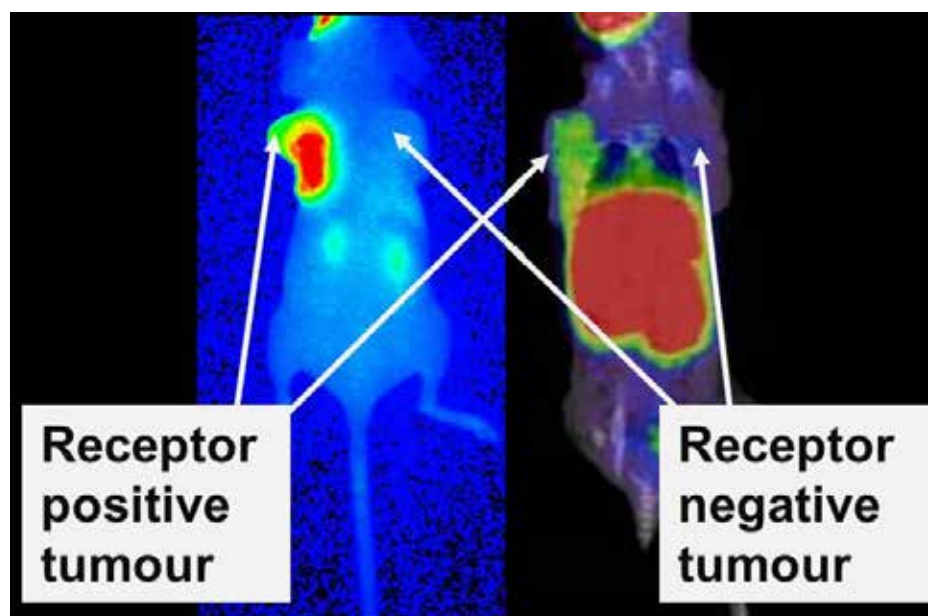

Fig. 1: Imaging of tumour bearing mice after injection of a multimodality probe allowing both optical imaging (left) and nuclear imaging by PET (right). In both imaging specific accumulation only the tumour expressing the targeted receptor (left flank).

tions. In cooperations with the University of Uppsala, Olomouc and Nijmegen imaging properties of these promising compounds were established (see Fig. 1).

The FWF project 27844-BBL “Optimizing CCK2R targeting for theranostic nuclear medicine” (project leader: Priv.-Doz.Dr. Elisabeth von Guggenberg, PhD Maximilian Klingler) deals with the development of novel radiolabelled minigastrin analogues targeting cholecystikin-2 receptors for possible application in the diagnosis and therapy of medullary thyroid cancer and small cell lung cancer, as well as other CCK2R expressing malignancies. We have designed a pool of new stabilised MG analogues conjugated to the bifunctional chelator DOTA for radiolabelling with trivalent radiometals, such as ^{111}In for SPECT and ^{68}Ga for PET, and the therapeutic radiometals ^{90}Y and ^{177}Lu . With one of our most promising radioligands ^{111}In -DOTA-MGS4, we could successfully improve the tumour uptake (10% ID/g) and uptake in receptor-expressing organs (stomach, pancreas) while maintaining the kidney uptake low (4% ID/g). The promising properties become clear from the comparison with our lead structure ^{111}In -DOTA-MG11 as well as ^{111}In -CP04 a gastrin analogue under current clinical investigation (see Fig. 2). These results give high promise for a future clinical translation of this new radioligand.

Another topic is focused on the develop-

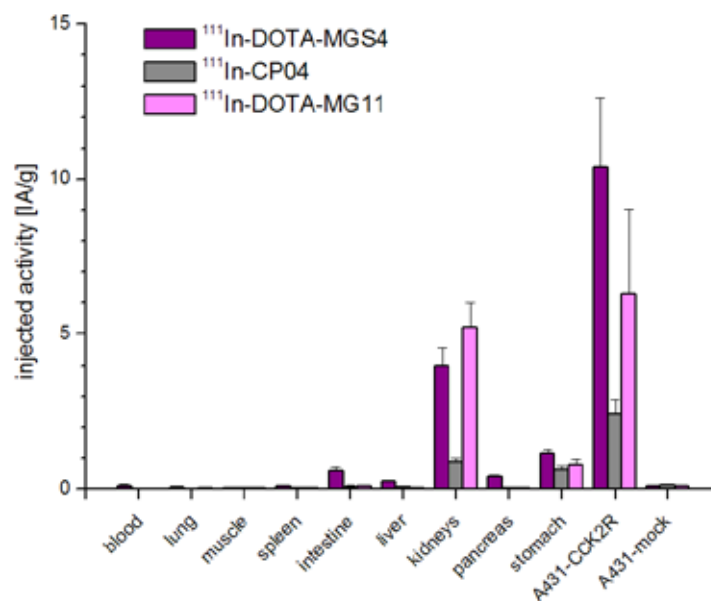

Fig. 2: Comparative biodistribution of ^{111}In -DOTA-MGS4 in A431-CCK2R and A431-mock xenografted mice at 4 h p.i.

ment of Ga-68-labelled galactosyl serum albumin derivatives for imaging functional liver reserve. In an initial study, it was demonstrated that Ga-68-DTPA-GSA strongly accumulates in the healthy liver of rats, which indicates the potential to be used for functional liver imaging. In a subsequent study, the in vivo stability was improved by replacement of DTPA with NOTA, a more

suitable chelator for Ga. These studies provided two potential tracers for non-invasive determination of the asialoglycoprotein receptor and will be studied in humans during the next stage.

Clinical Research Activities

ERA-NET

The ERA-NET project “Phase I clinical trial using a novel CCK-2/gastrin receptor-localizing radiolabelled peptide for personalized diagnosis and therapy of patients with progressive or metastatic medullary thyroid carcinoma” (FWF project I1224-B19, project leader: Prof. Clemens Decristoforo) aims to translate a new promising cholecystikin-2-receptor targeting peptide CP04 (DOTA-DGlu-DGlu-DGlu-DGlu-DGlu-DGlu-Ala-Tyr-Gly-Trp-Met-Asp-Phe-NH₂) for the diagnosis of medullary thyroid carcinoma (MTC) from bench to bedside. In the final part of this project, a multicentric clinical trial has been initiated and the first patients to be studied including the Nuclear Medicine Department at the Medical University Innsbruck. So far, results show a promising accumulation of this targeted radiolabelled peptide in metastases of medullary thyroid carcinoma, opening new ways for diagnosis and treatment of this rare disease.

Prostate Cancer Theranostics

New radiotracers binding to PSMA significantly increased expression on prostate cancer (PC) cells and have been proposed



Fig. 3: ^{68}Ga -PSMA-HBED-CC PET/CT before ^{177}Lu -PSMA617 therapy (left), after two (12.1 GBq; middle) and three therapy cycles (18.1 GBq; right). The SUVmax value decreased from 27.7 to 20.4 in skeletal metastases, from 37.9 to 23.9 in LN metastases and from 32.3 to 40.5 in liver metastases, whereas SUVmax also decreased from 17.8 to 10.4 in the parotid glands and from 23.2 to 14.2 in the sub-mandibular glands.

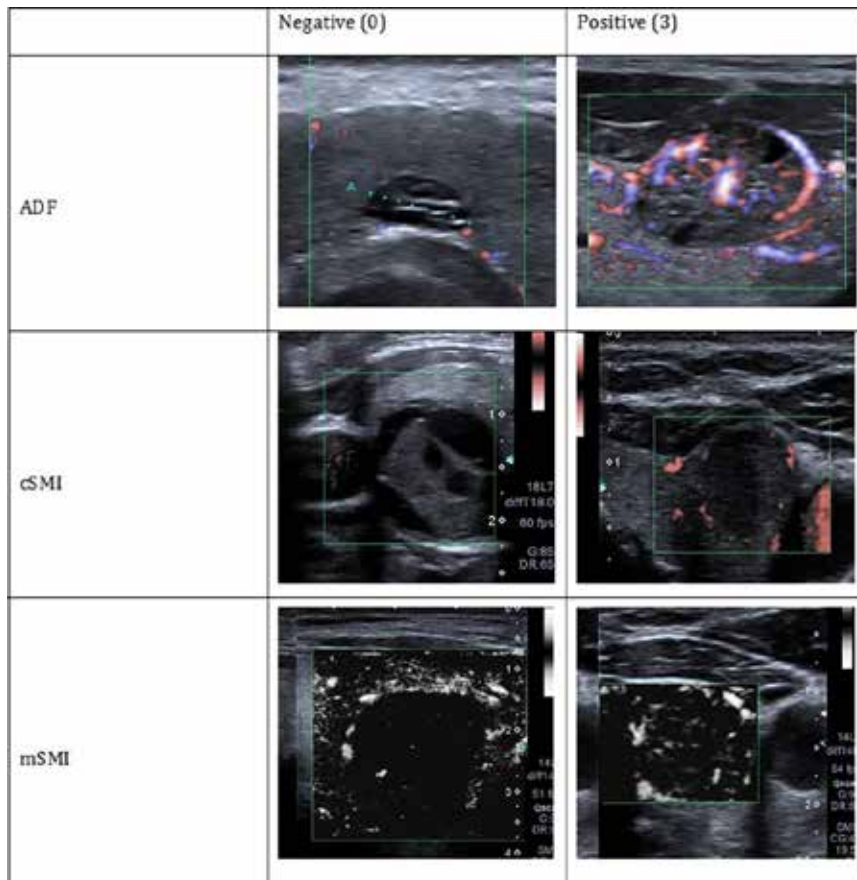

Fig. 4: Vascularization modes and typical patterns

for PET imaging. The ⁶⁸Ga-PSMA ligand HBED-CC proved its feasibility in detecting PC relapses and metastases with high sensitivity. Our extensive clinical studies demonstrated the great potential of ⁶⁸Ga-PSMA ligand PET/CT in patients with biochemical relapse. Recently ⁶⁸Ga-PSMA ligand PET/CT also indicated potential for staging of primary prostate cancer. Furthermore, based on the high level expression of PSMA on PC cells, we have started to treat patients with metastasised disease with high dose ¹⁷⁷Lu-PSMA ligand. Initial results demonstrate high tumour control ability of this radiopharmaceutical with significant implication on future PC therapy protocols. (see Fig. 3)

Thyroid Research Activities

Our recent thyroid research activities concentrated on the therapy options of radioiodine-refractory thyroid cancer. Several potential kinase inhibitors were clinically implemented, however they come with a rather broad range of side effects. Radio-labelled somatostatin analogues were clinically implemented for treatment by our group. The diagnosis and therapy of the MTC-subtype is addressed by the ERA-NET

Transcan project as well as by the FWF project 27844-BBL (see above).

Further research in the field of thyroid disease is being carried out on the basis of ultrasound imaging. We are currently investigating the utility of 3-dimensional imaging together with detailed depiction of the vascular system.

Ultrasounds were performed using two probes: linear 8-18 MHz transducer for routine imaging at 12 MHz together with specialised perfusion modes, i.e. mSMI and cSMI. mSMI stands for monochrome Superb Micro-Vascular Imaging and cSMI for color Superb Micro-Vascular Imaging. The advanced dynamic flow mode (ADF) was used routinely for depicting perfusion. In a second examination step, a 3D image was obtained using the 7.2-14 MHz 3D/4D probe. ADF was also used to demonstrate perfusion. (see Fig. 4)

MITIGATE

In this EU-FP7 project (grant agreement no 602306), new ways for diagnosis and treatment of therapy resistant Gastrointestinal Stromal Tumours (GIST) are being investigated and developed. At the Nuclear Medicine department of the Medical University a



Fig. 5: Imaging of Liver metastasis of a therapy resistant GIST. Specific binding of ⁶⁸Ga-NeoBOMB1 to Gastrin Releasing Peptide Receptors leads to delineation of the tumour only one hour after injection.

Phase I clinical trial with a novel radiopharmaceutical (⁶⁸Ga-NeBOMB1) was started (EUDRACT No 2016 002053-38). This kit-based radiopharmaceutical is radiolabelled with Gallium-68 targeting the gastrin releasing peptide receptor that is over-expressed in GIST. This opens new ways for non-invasive molecular characterisation of this rare tumour type and could lead to novel strategies for targeted treatment. The first patients have been enrolled in this trial and the first images are promising to identify GIST lesions that are resistant to conventional therapies. (see Fig. 5)

Angiogenesis Imaging

With Ga-68-NODAGA-RGD, we developed a tracer for the non-invasive determination of the integrin avb3 expression. This compound was studied in a phase I/II clinical trial and has shown rapid predominantly renal elimination with low background activity in most of the body (see Fig. 6). The calculated effective dose was comparable to routinely-used radiopharmaceuticals and the compound was well tolerated (Haubner et al. EJNMMI 2016). In further studies, uptake in different tumour lesions will be considered.

Quality of Life

Patients treated with radiopharmaceuticals are usually already at an advanced stage of disease and due to regulations of radiation safety they have to stay isolated for the period of radioactive treatment. This causes an additional level of anxiety for patients. To support the wellbeing and well feeling of the patients we have initiated translational projects integrating not only psychooncologists but also theologians, psychologists and nutritionists for the patients' supportive

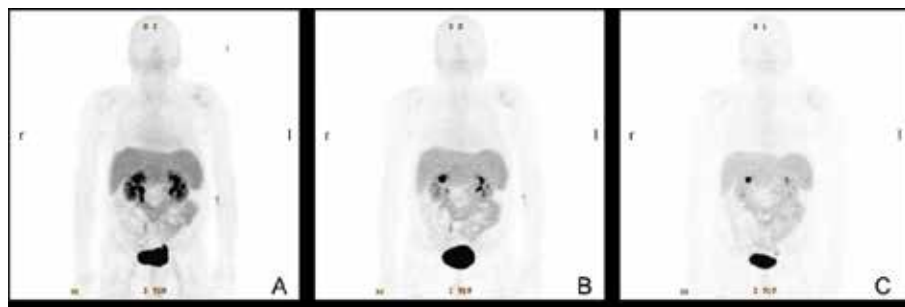

© EJNMMI, 2016

Fig. 6: Maximum intensity projections from static [^{68}Ga]NODAGA-RGD PET scans of a male patient (no. 3) with HCC starting at 13 min (A), 40 min (B), and 76 min (C) after tracer injection. The tracer shows rapid predominant renal elimination with the highest radioactivity in the bladder, kidneys, liver, spleen, and intestine. Low background radioactivity is found in the brain, thorax, and extremities. For all three images, greyscale is set to the same values.

care.

The strong correlation of gastrointestinal symptoms and psychosocial issues with quality of life warrant more detailed analyses of our data in order to identify predictors for quality of life in the specific patient group with neuroendocrine tumours considering physical as well as emotional and social domains and their relationship.

Selected Publications

Current knowledge on the sensitivity of the Ga-68-somatostatin receptor positron emission tomography and the SUVmax reference range for management of pancreatic neuroendocrine tumours

Virgolini, Irene, Gabriel, Michael, Kroiss, Alexander, von Guggenberg, Elisabeth, Prommegger, Rupert, Warwitz, Boris, Nilica, Bernhard, Roig, Ilanos Geraldo, Rodrigues, Margarida, Uprimny, Christian, EUROPEAN JOURNAL OF NUCLEAR MEDICINE AND MOLECULAR IMAGING: 2016; 43: S. 2072-2083

[Ga-68]NODAGA-RGD - Metabolic stability, biodistribution, and dosimetry data from patients with hepatocellular carcinoma and liver cirrhosis

Haubner, Roland, Finkenstedt, Armin, Stegmayr, Armin, Rangger, Christine, Decristoforo, Clemens, Zoller, Heinz, Virgolini, Irene J., EUROPEAN JOURNAL OF NUCLEAR MEDICINE AND MOLECULAR IMAGING: 2016; 43: S. 2005-2013

Targeting Gastrointestinal Stromal Tumor with Ga-68-Labeled Peptides: An In Vitro Study on Gastrointestinal Stromal Tumor-Cell Lines

Paulmichl, Achim, Summer, Dominik, Manzl, Claudia, Rangger, Christine, Orlandi, Francesca, Niedermoser, Sabrina, Taguchi, Takahiro, Waengler, Bjoern, Decristoforo, Clemens, CANCER BIOTHERAPY AND RADIOPHARMACEUTICALS: 2016; 31: S. 302-310

Systematic review reveals lack of quality in reporting health-related quality of life in patients with gastroenteropancreatic neuroendocrine tumours

Martini, Caroline, Gamper, Eva-Maria, Wintner, Lisa, Nilica, Bernhard, Sperner-Unterwieser, Barbara, Holzner, Bernhard, Virgolini, Irene, HEALTH AND QUALITY OF LIFE OUTCOMES: 2016; 14: S. 127

From preclinical development to clinical application: Kit formulation for radiolabelling the minigastrin analogue CPO4 with In-111 for a first-in-human clinical trial

Pawlak, Dariusz, Rangger, Christine, Peitl, Petra Kolenc, Garnuszek, Piotr, Maurin, Michal, Ihli, Laura, Kroselj, Marko, Maina, Theodosia, Maecke, Helmut, Erba, Paola, Kremser, Leopold, Hubalewska-Dydejczyk, Alicja, Mikolajczak, Renata, Decristoforo, Clemens, EUROPEAN JOURNAL OF PHARMACEUTICAL SCIENCES: 2016; 85: S. 1-9

Pelvic Lymph Node Staging by Combined (^{18}F -FDG-PET/CT Imaging in Bladder Cancer Prior to Radical Cystectomy. Pichler, Renate, De Zordo, Tobias, Fritsch, Josef, Kroiss, Alexander, Aigner, Friedrich, Heidegger, Isabel, Virgolini, Irene, Horninger, Wolfgang, Uprimny, Christian, CLINICAL GENITOURINARY CANCER: 2016; [Epub ahead of print]: S.

Comparison of Ga-68-Labeled Fusarinine C-Based Multivalent RGD Conjugates and [Ga-68]NODAGA-RGD-In Vivo Imaging Studies in Human Xenograft Tumors

Zhai, Chuangyan, Franssen, Gerben M., Petrik, Milos, Laverman, Peter, Summer, Dominik, Rangger, Christine, Haubner, Roland, Haas, Hubertus, Decristoforo, Clemens, MOLECULAR IMAGING AND BIOLOGY: 2016; 18: S. 758-767

Targeting Gastrointestinal Stromal Tumor with Ga-68-Labeled Peptides: An In Vitro Study on Gastrointestinal Stromal Tumor-Cell Lines

Paulmichl, Achim, Summer, Dominik, Manzl, Claudia, Rangger, Christine, Orlandi, Francesca, Niedermoser, Sabrina, Taguchi, Takahiro, Waengler, Bjoern, Decristoforo, Clemens, CANCER BIOTHERAPY AND RADIOPHARMACEUTICALS: 2016; 31: S. 302-310

Selected Funding

"Enhanced CCK2R targeting for theragnostic use in nuclear medicine", FWF: Projekt Nr. P. 27844, Priv.-Doz.Dr. Elisabeth von Guggenberg / 339.378,39 Euro

Collaborations

- Prof. Dr. Richard Baum, Zentralklinik Bad Berka, Bad Berka, Germany
- Prof. Dr. John Buscombe, Cambridge University Hospitals, Cambridge, UK
- Prof. Pietro Muto, Ospedale dei Colli, Monaldi, Italia
- Prof. Annibale Versari, Az. Osp. Arcispedale S.Maria Nuova, Reggio Emilia, Italia
- Prof. Stefano Fanti, Policlinico S.Orsola-Malpighi, Bologna, Italia
- Dr. Chiara Maria Grana, IEO Istituto Europeo di Oncologia, Milano, Italia
- Prof. Helmut Maecke, University Hospital Freiburg, Freiburg, Germany
- Prof. Georgios S Limouris, Athens University Medical Faculty, Athens, Greece
- Prof. Dr. Thomas Beyer, Medical University Vienna, Vienna, Austria
- Prof. Dr. Marcus Hacker, Medical University Vienna, Vienna, Austria
- Prof. Dr. Bernd Pichler, Eberhard Karls University Tübingen, Tübingen, Germany
- Prof. Dr. Olaf Prante, Friedrich Alexander University, Erlangen, Germany
- Dr. Milos Petrik, Palacky University Olomouc, Czech Republic
- Prof. Renata Mikolajczak, Radioisotope Centre POLATOM, Otwock, Poland
- Research Report MUI 2016: Input Form 10/10
- Prof. Björn Wängler, Prof. Stefan Schönberg, Medical Faculty Mannheim of Heidelberg University, Mannheim, Germany
- Prof. Paola Erba, Azienda Ospedaliero-Universitaria Pisana, Pisa, Italy
- Prof. Alicja Hubalewska-Dydejczyk, Jagiellonian University Medical College, Krakow, Poland
- Dr. Petra Kolenc-Peitl, University Medical Centre Ljubljana, Slovenia
- Dr. Peter Laverman, Radboud University Medical Center, Nijmegen, Netherlands
- Prof. Jane K. Sosabowski, Queen Mary University of London, London, UK
- Prof. Vladimir Tolmachev, University Uppsala, Sweden
- Prof. Jean-Noël Talbot, AP-HP & Université P&M Curie, Paris, France
- Prof. David R. Vera, University of California, San Diego, United States
- Prof. Stanley J. Goldsmith, Weill Cornell Medical College, New York, United States
- Prof. Ajit Shinto, Kovai Medical Centre and Hospital, Coimbatore, India
- Prof. Anthony Goh, Singapore General Hospital, Singapore
- Prof. Emerita Andres-Barrenechea, St. Luke's Medical Center, Quezon City, Philippines
- Prof. Harvey Turner, University of Western Australia, Murdoch, Australia
- Prof. Mike Sathekge, University of Pretoria, Pretoria, South Africa
- Prof. N. Ozlem Küçük, Ankara University, Ankara, Turkey
- Prof. Levent Kabasakal, Istanbul University, Istanbul, Turkey

Therapeutic Radiology & Oncology



Director:
o. Univ.-Prof. DI Dr. Peter Lukas

Contact:
Anichstraße 35
6020 Innsbruck

radioonkologie-sekretariat@i-med.ac.at
Phone: +43 512 504 22801
Fax: +43 512 504 22869
<http://www3.i-med.ac.at/strahlentherapie>

Research Branch (ÖSTAT Classification)

302080, 302055, 301904,
302058, 302044,

Keywords

Radiotherapy, oncology, radiosurgery, radiation biology, radiation protection, medical physics, medical biotechnology, medical molecular biology, cell biology, nanobiotechnology

Research Focus

Major research topics are:

Radio-Sensitizing in Radiation Oncology: Many of the new systemic substances used in Oncology have a radiosensitizing (RSP) or radioprotective(RPP) potential. Often little is known about these properties before going into clinical use because investigation in this concern is not part of the EU guidelines for marketing authorisation. For Radio-oncologists the knowledge of RSP or RPP is essential for the planning of any form of combined treatments.

High Precision Radiotherapy: Our Insti-

tution is worldwide famous for the development of Patient Fixation Devices for high precision radiotherapy.

Radiobiology: Impact of low doses for the induction of secondary malignoma; cell culture modelling, nano-particle applications in vitro, modelling of micro-fluidics, electro-spinning of nano-fibrous cell culture substrates, developing cell-to-electrode interfaces at micron-scales.

General Facts

Peter Lukas has headed the Department of Therapeutic Radiology and Oncology (ROI) at the Medical University of Innsbruck (MUI) since 1993. He has introduced several improved treatment techniques in radiotherapeutic routine, nowadays globally accepted as standard treatment protocols (see publication 1). Beside his clinical experience, Peter Lukas has strongly promoted basic and translational research in the field of radiobiology at his department.

The Dept. of Therapeutic Radiology and Oncology (MUI) comprises eight units to perform therapeutic as well as experimental irradiation (five linear accelerators to generate photon beams of energies up to 20 MeV; two Brachytherapy units, and a conventional x-ray-device up to 200 keV. Further Information under: <http://www3.i-med.ac.at/strahlentherapie>.

The first associated Laboratory of Radiobiology (headed by **Thomas Seppi**) disposes of experienced staff personnel (four VPs) skilled in a broad spectrum of cell biology as well as in nano-technological methodologies.

Equipment is available to perform flow cytometry analyses, long-term live-cell imaging (by light and fluorescence techniques), proteomics, metabolomics, intracellular ROS-quantification, advanced cell and tissue culturing (in-house fabrication of nano-fiber scaffolds, 2D- and 3D-perfusion culture models), impedance and TEER-methods to assess tissue integrity, cell-migration tracking, as well as uptake studies and subcellular localization of nano-particles by scanning and transmission electron microscopy.

The second associated laboratory is the Laboratory for Experimental and Translational Research on Radiation Oncology (EXTRO-Lab), headed by **Ira Skvortsova**. This laboratory was established in 2006 (http://www3.i-med.ac.at/strahlentherapie/de/05_lab1.php).

Research

Peter Lukas

Main international involvement of the institution is concerning the quality of radiation treatment in Hodgkin's Lymphoma (see publication 2). Peter Lukas is member of the Quality Panel on Radiation Treatment (Radiotherapy Panel) of the German Hodgkin Study Group (GHSG).

Main institutional Projects in 2015/16 besides concluding the pre-described SEMPER project have been concerning radiotherapy of breast cancer.

The Institution, represented by Dr. Danjela Vasiljevic, planned, conducted and finished a prospective trial on the incidence and reasons for radiotherapy related pneumonitis, including 400 patients. Analysis is on-going, publication is in preparation.

In addition we prepared the participation in a German trial on hypofractionation and integrated boost (HYPOSIB), patient acquisition will start April 2017. Responsible for mentoring: Dr. Danjela Vasiljevic.

The group of Arnold et al. prepared a paper on the evaluation of a domestic porcine model for studying the effects of radiation in head and neck cancer (see publication 3).

Ira-Ida Skvortsova (EXTRO-Lab, Dept. of Therapeutic Radiology and Oncology, Innsbruck Medical University, Innrain 66A, Floor 3, Room 15, 6020 Innsbruck)

The main aim of the EXTRO-Lab is to develop novel biomarkers predicting radiation response of malignant tumors and/or therapeutic targets that could be used for improvement of the radiotherapy outcome in cancer patients (see publication 4). EXTRO-Lab has four permanent members and three cooperative members.

Our research group recently reported that radioresistant prostate and breast carcinoma cell lines with high CSC content overexpress Ape1/Ref1 protein, which has a dual function as a ROS scavenger and as a DNA repair enzyme. Attenuation of Ape1/Ref1 expression was accompanied by the restoration of radiation sensitivity in prostate carcinoma cells. Ape1/Ref1 is a protein consisting of two domains: the N-terminal domain which is responsible for the redox activity, and the C-terminal domain which is essential for DNA repair.

As already mentioned above, CSCs have unique capacities to reduce intracellular ROS levels and thus to protect themselves against ROS-caused DNA damage and cell death. Their constitutive up-regulation of

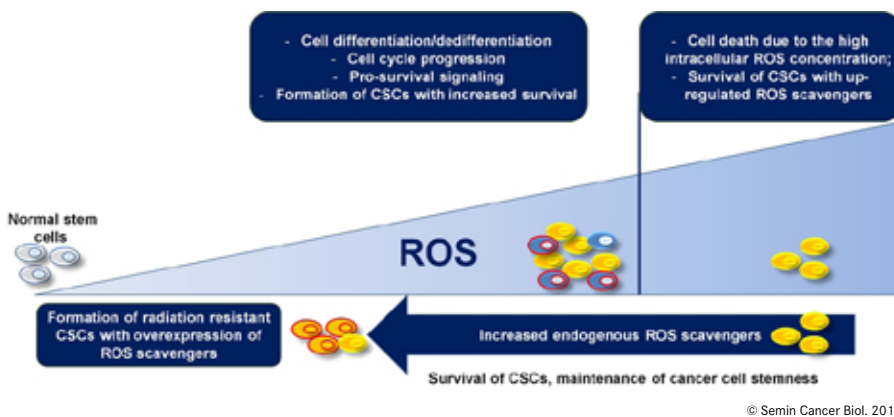

Selected Publications

1.) Long-term surveillance of locally advanced rectal cancer patients with neoadjuvant chemoradiation and aggressive surgical treatment of recurrent disease: a consecutive single-centre experience
Zitt, Matthias, DeVries, Alexander, Thaler, Josef, Kafka-Ritsch, Reinhold, Eisterer, Wolfgang, Lukas, Peter, Oefner, Dietmar, INTERNATIONAL JOURNAL OF COLORECTAL DISEASE: 2015; 30: S. 1705-1714

2.) Relapse Analysis of Irradiated Patients Within the HD15 Trial of the German Hodgkin Study Group
Kriz, Jan, Reinartz, Gabriele, Dietlein, Markus, Kobe, Carsten, Kuhnert, Georg, Haverkamp, Heinz, Haverkamp, Uwe, Engenhardt-Cabillic, Rita, Herfarth, Klaus, Lukas, Peter, Schmidberger, Heinz, Staar, Susanne, Hegerfeld, Kira, Baues, Christian, Engert, Andreas, Eich, Hans Theodor, INTERNATIONAL JOURNAL OF RADIATION ONCOLOGY BIOLOGY PHYSICS: 2015; 92: S. 46-53

3.) Proteomic approach to understand metastatic spread
Skvortsov, Sergej, Arnold, Christoph R., Debbage, Paul, Lukas, Peter, Skvortsova, Ira, PROTEOMICS CLINICAL APPLICATIONS: 2015; 9: S. 1069-1077

4.) Sex Differences in Renal Proximal Tubular Cell Homeostasis
Seppi, Thomas, Prajczor, Sinikka, Doerler, Maria-Magdalena, Eiter, Oliver, Hekl, Daniel, Nevinny-Stickel, Meinhard, Skvortsova, Iraida, Gstraunthaler, Gerhard, Lukas, Peter, Lechner, Judith, JOURNAL OF THE AMERICAN SOCIETY OF NEPHROLOGY: 2016; 27: S. 3051-3062

Selected Funding

- i-Scaff - Intelligent scaffolds of electro-spun nano-fibres in advanced cell culture models, TZS-Translational Research Program, Seppi T, Schmiedinger T (294.000 €)
- FWF Project P29457 (Priv.-Doz. Dr. Ira-Ida Skvortsova)

Collaborations

- Fachhochschule Vorarlberg, Feldkirch, Austria
- Unit of Hydraulic Engineering, University of Innsbruck; Innsbruck
- Institute of Physics, Academy of Sciences Prague, Prague, Czech Republic
- Università del Sacro Cuore, Rome, Italy
- Department of Engineering, University of Trento, Trento, Italy
- Anna Dubrovka, OncoRay - National Center for Radiation Research in Oncology
- Medical Faculty Dresden Carl Gustav Carus, TU Dresden Fetscherstr. 74 / PF41 01307 Dresden, Germany
- Connie R. Jimenez, OncoProteomics Laboratory, Dept. Medical Oncology, VUmc-Cancer Center Amsterdam, Room CCA 1-60, De Boelelaan 1117, 108 1HV Amsterdam, The Netherlands
- Emilie Varin, Translational Research Officer, EORTC, Avenue E. Mounier 83/11, Brussels, Belgium
- Takashi Imai, Advanced Radiation Biology Research Program, Research Center for Charged Particle Therapy, National Institute of Radiological Sciences, 4-9-1 Anagawa, Inage, Chiba 263-8555 Japan
- Silvia Pastorekova, Institute of Virology, Slovak Academy of Sciences, Dubravska cesta 9, 84505 Bratislava, Slovakia
- MedAustron, Wiener Neustadt, Austria
- University for Health Sciences, Medical Informatics and Technology (UMIT), Hall i.T./Department of Biomedical Computer Science and Mechatronics
- Zentrum für Biomedizin; EURAC, Bozen, Italy

Fig. 1: Intracellular ROS and formation of radiation-resistant CSCs. It is assumed that CSCs may be generated from normal stem cells. An increased concentration of intracellular ROS enhances processes involved in cell differentiation/de-differentiation, in dysregulated cell cycle progression, in activation of pro-survival signalling, in accumulation of gene mutations, and in genome instability. Acting together, all these ROS-mediated intracellular processes generate the most aggressive treatment-resistant carcinoma cells, which have stem-ness characteristics. In order to protect themselves from ROS-induced damage, these CSCs overexpress ROS scavengers. Finally, malignant tumours become enriched for the radiation-resistant CSC subpopulation having up-regulated ROS scavengers and lower ROS concentrations.

ROS scavengers, including Ape1/Ref1, may be induced by factors belonging to the microenvironmental CSC niche, such as hypoxia, or release of pro-inflammatory cytokines, or dysregulation of mitochondrial functions. The formation of CSCs, with their constitutive up-regulation of enzymes directed to ROS scavenging and DNA repair, may explain primary radiation resistance, whereas an enhancement of their expression accompanying radiotherapy may underlie acquired radiation resistance. Note that an imbalance between ROS formation and the expression of ROS scavengers, favouring increased intracellular ROS levels, can activate CSC differentiation. In contrast, downregulation of ROS formation leads to enhanced CSC self-renewal, with more pronounced cancer cell aggressiveness. Inhibition of the redox function of Ape1/Ref-1 initiates cell differentiation followed by cell death in H₂O₂-treated cardiac stem cells. Similar processes might also be observed in CSCs. Furthermore, Ape1/Ref1 regulates the redox status of a variety of signaling molecules, including p53 protein: its reduction of oxidized p53 enhances p53 and DNA binding, and modulates DNA repair. Alterations in p53 functions can result in inaccurate and defective DNA repair, in formation of additional DNA mutations, in genome instability and finally in the enhancement of CSC survival and CSC aggressiveness. In carcinoma cells, ROS scavenging by proteins such as Ape1/Ref1 can reduce radiation sensitivity, and can also

affect cell growth and the cell cycle. It is currently not fully understood how ROS and ROS scavengers regulate CSC survival and cell cycle progression, but it is plausible to hypothesize that ROS scavenging can lead to generation of the most aggressive slowly proliferating radioresistant CSCs.

Thomas Seppi

The associated Laboratory of Radiobiology conducted several projects in the field of nano-technology and tissue engineering funded by the Austrian Nano-Initiative (FFG) or by other peer reviewed governmental grants. The team, headed by Thomas Seppi, is experienced in radiobiology, analytical chemistry, nano-coatings in biomedical applications, laser-optical cell analyses, electron-microscopy protocols, designing and prototyping of advanced cell culture models, as well as in molecular biology and toxicology of cancer cells.

A main objective of ongoing projects - performed in collaboration with several local and international partners - is to synthesize advanced nanoparticles (NPs) composed by a coated super-paramagnetic iron oxide core (SPIOs), to accommodate chemotherapeutics on the surface of NPs, and to investigate the potential of inducing drug release by gamma-ray/proton dilation as a trigger modality. NPs made of heavy metals, such as gold, may enhance the efficacy of cancer radiotherapy by increasing the local absorption of photon as well as proton radiation.

Dermatology, Venereology and Allergology & Experimental Dermatology Research Unit



Director:
Univ.-Prof. Dr. Matthias Schmuth

Contact:
Anichstraße 35
6020 Innsbruck

Matthias.Schmuth@i-med.ac.at
Phone: +43 512 504 24801
Fax: +43 512 504 23002
<http://dermatologie.tirol-kliniken.at>



Head of Experimental Dermatology:
Univ.-Prof. Dr. Nikolaus Romani

Contact:
Anichstraße 35
6020 Innsbruck

Nikolaus.Romani@i-med.ac.at
Phone: +43 512 504 28559
Fax: +43 512 504 23002

Research Branch (ÖSTAT Classification)

302011, 301902, 301904,
302002, 302087

Keywords

dendritic cells, Langerhans cells, genodermatoses, histiocytoses, HIV, lupus, melanoma, parasitoses, psoriasis, epidermal barrier

Research Focus

The dermatology research programs can be subdivided into the following major research topics:

- Dendritic cells/Langerhans cells/Immunobiology of the skin
- Epidermal biology
- Genodermatoses
- Cutaneous autoimmunity
- Infectious diseases of the skin, HIV/AIDS
- Dermatohistopathology
- Photomedicine
- Clinical trials

General Facts

In the dermatology department, basic research and patient care are intimately interconnected with each other. This will ultimately be of advantage to our patients, who will be able to benefit from new diagnostic and therapeutic approaches early in development. For instance, dendritic cell-based vaccination strategies against melanoma were developed and applied. Innsbruck dermatology's researchers have played a leading role in the development of methods for the isolation, propagation and clinical application of these cells over the past three decades. Another prominent example is the investigation of the skin barrier function in healthy and diseased skin. Additional, equally interconnected research programs focus on the cutaneous immune system, autoimmunity, infectious diseases of the skin, HIV infection, and dermatohistopathology.

Research

Differential Effects of Allergens and Non-Allergenic Antigens on Human Dendritic Cells

*Christine Heufler Tiefenthaler,
Norbert Reider*

Patients suffering from type I, IgE-mediated allergies constitute an important clientele of our department. Dendritic cells initiate and regulate virtually all immune reactions in the body, including the undesired allergic hypersensitivities. It is still unclear why chemically

closely related molecules of the lipocalin family can be either allergenic or non-allergenic. We worked on identifying the molecular basis for these differential responses in human dendritic cells exposed to non-allergenic and allergenic lipocalins, the most frequent group of animal derived respiratory allergens.

Differential T cell responses and broad gene expression analyses of dendritic cells were performed by microarray. Candidate molecules were identified, and their intracellular trafficking and processing by dendritic cells are now being studied in detail. Furthermore, molecular alterations of allergens were investigated with the aim of rendering allergenic molecules non-allergenic. The expected results will add to our knowledge of the fundamental biology of dendritic cells and may help to better understand the development of allergies to respiratory antigens.

Immunological Studies on Dendritic Cells of the Skin: Immunosurveillance against Cancer and potential Clinical Application for Immunotherapy

*Patrizia Stoitzner, Daniela Ortner-Tobider,
Christoph Tripp*

The main topic of our research in the Laboratory for Langerhans Cell Research, headed by Assoc.-Prof. Stoitzner, is the immunobiology of the different types of skin dendritic cells, with emphasis on epidermal Langerhans cells (Figure 1). The immunogenic function of Langerhans cells has been investigated in the context of skin cancer (melanoma and squamous cell / basal cell carcinoma). Hereby, different mouse tumor models, including spontaneously arising melanoma, have been used to determine the phenotype of tumor infiltrating dendritic cells and effector cells, such as T cells and natural killer T cells. The occurrence and function of myeloid suppressor cells and their influence on the growth of tumors was studied.

Importantly, mouse models, in which defined subsets of skin dendritic cells can be depleted, have helped to identify the critical role of Langerhans cells for the prevention of chemically induced squamous cell carcinoma (Figure 2). Crosstalk between Langerhans cells and Natural Killer Cells was found to be essential for the control of this type of skin cancer. Based on these findings we currently attempt to develop novel alternative immunotherapies which can be tested for their efficacy in mouse tumor models and eventually translated into human medicine. As a first step we have investigated the direct targeting of dendritic cells in the skin with

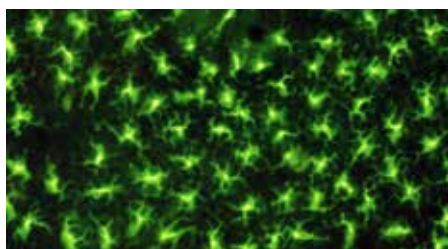

Fig. 1: Network of Langerhans cells in an epidermal sheet specimen. Approximately 700 Langerhans cells reside in one square millimetre. These cells are directly targeted in situ by antibody-coupled vaccines.

antibody-antigen conjugates (anti-DEC-205, anti-langerin), by intradermal application in a human skin explant model. Different dendritic cell subsets, such as Langerhans cells and dermal dendritic cells were targeted differently. Subsequently, T cell stimulatory functions of targeted skin dendritic cells were studied in this model, using an EBV-based T cell read-out that will eventually lead to a model with melanoma tumor antigens (NY-ESO-1). We are testing the hypothesis that such antibody-conjugated antigens elicit massively augmented T cell responses. First observations within this reporting period suggest that this is indeed the case. Such immunizations, for instance against neoantigens in cancer, could prove highly useful in tandem with modern immune checkpoint therapies.

Epidermal Biology

Sandrine Dubrac, Robert Gruber, Verena Moosbrugger-Martinz

This research group focuses on the biological processes that regulate the interplay between skin barrier function and cutaneous

inflammation. Alterations in T-cell subsets, lipid metabolites and in cellular metabolism involving mitochondria are the focus of ongoing research. Gene mutations relevant for epidermal function are tested in 3D skin cultures and compared with biopsies from patients carrying these mutations. *In vitro* 3D culture models allow for mechanistic studies, forming the basis for new therapeutic concepts, which in turn can be tested in the models. Discovery of disease-causing mutations in patients with hereditary skin disease (i.e. disorders of cornification and atopic dermatitis), carried out in collaboration with the Human Genetics Division, feeds into this approach. Various microscopic techniques including confocal imaging and electron microscopy (Figure 3) are used to decipher the consequences of mutations on epidermal structure and function.

The collaboration with Human Genetics also extends to studying connective tissue disease. Another line of research explores the role of nuclear hormone receptors (PPAR, LXR) in regulating inflammation and epidermal differentiation. Recently, we discovered Pregnane X receptor (PXR), a transcription factor mainly known to be expressed in liver and intestine to be activated by xenobiotic chemicals in skin, to protect from DNA damage and to modulate the cutaneous immune system.

Cutaneous Autoimmunity

Barbara Böckle, Gudrun Ratzinger

This group has established registries of autoimmune skin disorders. Thoroughly recorded clinical and immune parameters were integrated with information about response to therapy and thus provided a rich scientific resource with which to address questions of

both disease mechanisms and therapeutic strategies. Recent work has demonstrated serologic markers of malignancy in patients with autoimmune disease.

Infectious Diseases of the Skin

Robert Zangerle, Mario Sarcletti, Martin Gisinger, Maria Kitchen-Hosp, Reinhard Höpfl

This research program addresses questions of HIV epidemiology and response to therapy using the large national OEHIVKOS cohort that was initiated, and is led by researchers from the Innsbruck Department of Dermatology. The cohort is increasingly linked to European and international collaborative efforts, e.g. the Antiretroviral Therapy Cohort Collaboration (ART-CC), the Collaboration of Observational HIV Epidemiological Research Europe (COHERE) in EuroCoord, the CASCADE Collaboration in EuroCoord, and EuroSIDA in EuroCoord. Additional research addressed sexually transmitted infections (STI) and skin disorders caused by viruses (HPV), as well as by various parasites and fungi.

Photomedicine

Gudrun Ratzinger

This research program addresses the effects of UV-irradiation as a causative factor of photodermatoses, as well as the therapeutic effects of UV-irradiation on common inflammatory skin diseases and skin cancer. Ongoing trials investigate the effects of phototherapy on the autoimmune skin disorder scleroderma and on cutaneous T-cell lymphoma. Additionally, the group participates in the Austrian Psoriasis Registry (PsoRA) to gain clinical and epidemiologic data.

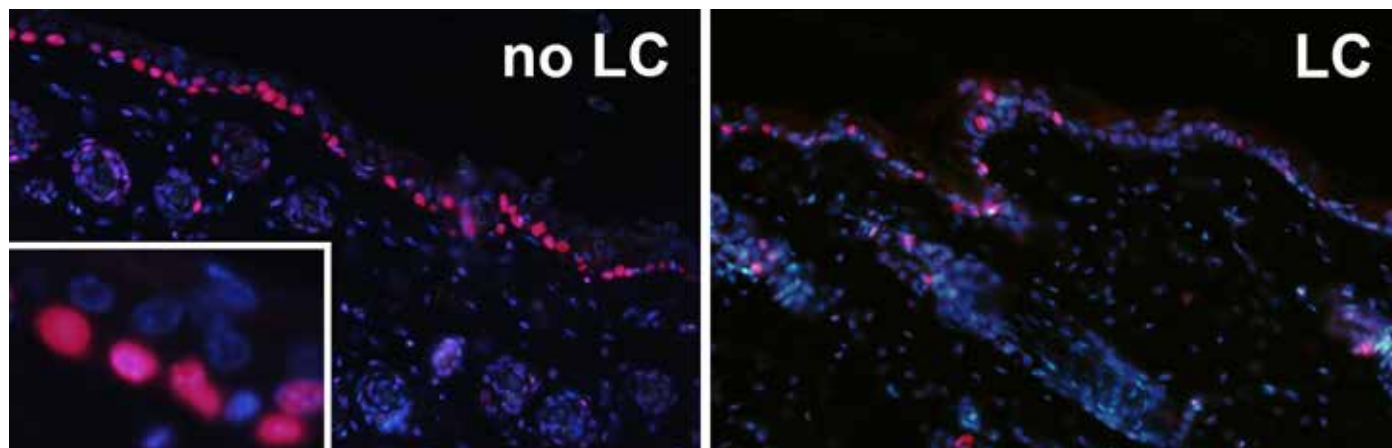

Fig. 2: Mouse skin treated with a cancerogenic substance and immunolabeled for visualization DNA damage (red fluorescence). Epidermis from mice, where Langerhans cells had been removed experimentally by means of the diphtheria toxin receptor approach („no LC“) have markedly more damaged cell nuclei. This illustrates a novel protective role of Langerhans cells (in collaboration with natural killer cells) in skin cancer. Ortner et al., Oncoimmunology.

Dermatohistopathology

Bernhard Zelger

Dermatohistopathology research in Innsbruck is renowned for innovative concepts describing a variety of morphologic discoveries in many skin disorders (Figure 4), with special emphasis on soft tissue tumors and cutaneous vasculitis. Collaborative research projects included studies characterizing inflammation and rejection in limb transplantation.

Clinical Trials

Norbert Reider, Gudrun Ratzinger, Robert Zangerle, Van Anh Nguyen, Georg Weinlich, Matthias Schmuth

The Department's clinical trial unit carried out numerous phase I-III clinical trials on chronic inflammatory skin disease (psoriasis), allergies, skin cancer (foremost melanoma), HIV and genetic skin diseases. Although most of our current trials are pharma-initiated, the Department also encouraged and supported the planning and implementation of investigator-initiated trials. The unit works in close collaboration with the Coordination Center for Clinical Trials (KKS) and the Comprehensive Cancer Center.

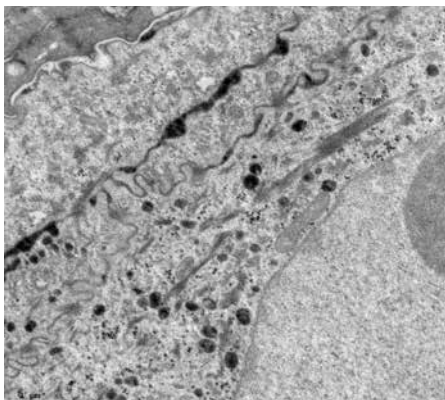

Fig. 3: Electron microscopic visualisation of lamellar bodies and secreted lipid contents in the intercellular space at the stratum granulosum - stratum corneum junction in the outer epidermis.

Selected Publications

Allergenic Can f 1 and its human homologue Lcn-1 direct dendritic cells to induce divergent immune responses
 Posch, Beate, Irsara, Christian, Gamper, Fabian S., Hermann, Martin, Bindreither, Daniel, Fuchs, Dietmar, Reider, Norbert, Redl, Bernhard, Heufler, Christine,
 JOURNAL OF CELLULAR AND MOLECULAR MEDICINE: 2015; 19: S. 2375-2384

Impaired gp100-Specific CD8(+) T-Cell Responses in the Presence of Myeloid-Derived Suppressor Cells in a Spontaneous Mouse Melanoma Model
 Mairhofer, David G., Ortner, Daniela, Tripp, Christoph H., Schaffenrath, Sandra, Fleming, Viktor, Heger, Lukas, Komenda, Kerstin, Reider, Daniela, Dudziak, Diana, Chen, Suzie, Becker, Juergen C., Flacher, Vincent, Stoitzner, Patrizia,
 JOURNAL OF INVESTIGATIVE DERMATOLOGY: 2015; 135: S. 2785-2793

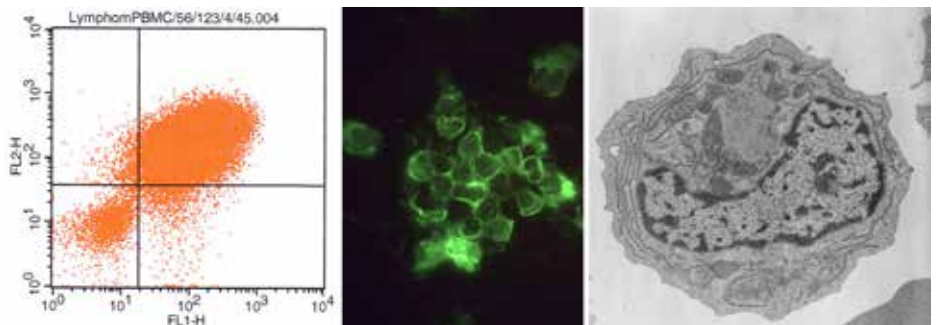

Fig. 4: Malignant cells in the blood of a patient with a plasmacytoid dendritic cell lymphoma, a very rare entity. This illustrates clinical research, bridging methodology from basic research, such as flow cytometry (left), immunofluorescence (middle) and electronmicroscopy (right) and diagnostic dermatohistopathology.

The Late Endosomal Adaptor Molecule p14 (LAMTOR2) Regulates TGFβ1-Mediated Homeostasis of Langerhans Cells

Sparber, Florian, Tripp, Christoph H., Komenda, Kerstin, Scheffler, Julia M., Clausen, Bjoern E., Huber, Lukas A., Romani, Nikolaus, Stoitzner, Patrizia,
 JOURNAL OF INVESTIGATIVE DERMATOLOGY: 2015; 135: S. 119-129

Still Alive and Kicking: In-Vitro-Generated GM-CSF Dendritic Cells!

Lutz, Manfred B., Inaba, Kayo, Schuler, Gerold, Romani, Nikolaus,
 IMMUNITY: 2016; 44: S. 1-2

Atopic dermatitis induces the expansion of thymus-derived regulatory T cells exhibiting a Th2-like phenotype in mice

Moosbrugger-Martinz, Verena, Tripp, Christoph H., Clausen, Bjoern E., Schmuth, Matthias, Dubrac, Sandrine,
 JOURNAL OF CELLULAR AND MOLECULAR MEDICINE: 2016; 20: S. 930-938

Skin response to a carcinogen involves the xenobiotic receptor pregnane X receptor

Elentner, Andreas, Ortner, Daniela, Clausen, Bjoern E., Gonzalez, Frank J., Fernandez-Salguero, Pedro M., Schmuth, Matthias, Dubrac, Sandrine,
 EXPERIMENTAL DERMATOLOGY: 2015; 24: S. 835-840

Epidermal barrier abnormalities in exfoliative ichthyosis with a novel homozygous loss-of-function mutation in CSTA

Moosbrugger-Martinz, V., Jalili, A., Schossig, A. S., Jahn-Bassler, K., Zschocke, J., Schmuth, M., Stingl, G., Eckl, K. M., Hennies, H. C., Gruber, R.,
 BRITISH JOURNAL OF DERMATOLOGY: 2015; 172: S. 1628-1632

Smoking is highly associated with discoid lupus erythematosus and lupus erythematosus tumidus: analysis of 405 patients

Boeckle, B. C., Sepp, N. T.,
 LUPUS: 2015; 24: S. 669-674

Evidence Of In Vivo Existence Of Borrelia Biofilm In Borreliolymphocytomas

Sapi, E., Balasubramanian, K., Poruri, A., Maghsoudlou, J. S., Socarras, K. M., Timmaraju, A. V., Filush, K. R., Gupta, K., Shaikh, S., Theophilus, P. A. S., Luecke, D. F., MacDonald, A., Zelger, B.,
 EUROPEAN JOURNAL OF MICROBIOLOGY & IMMUNOLOGY: 2016; 6: S. 9-24

Survival and Effectiveness of Tumour Necrosis Factor-alpha Inhibitors in the Treatment of Plaque Psoriasis under Daily Life Conditions: Report from the Psoriasis Registry Austria

Inzinger, Martin, Wippel-Slupetzky, Katharina, Weger, Wolfgang, Richter, Leo, Mylnek, Alexander, Fleischhanderl, Barbara, Schurecker, Christine, Sandor, Nicolaus, Mairhofer, Daniela, Sator, Paul G., Moser-Oberthaler, Sabine, Haering, Nina, Viznerova, Petra, Painsi, Clemens, Ianew, Adrian, Ponholzer, Peter, Tatarski, Rafaella, Brenner, Wilhelm, Stingl, Georg, Salmhofer, Wolfgang, Rappersberger, Klemens, Klein, Georg, Saxinger, Werner, Auboock, Josef, Koellli, Claudia, Trautinger, Franz, Steiner, Andreas, Ratzinger, Gudrun, Strohal, Robert, Riedl, Elisabeth, Lange-Asschenfeldt, Bernhard, Pehamberger, Hubert, Volz-Platzer, Beatrix, Selhofer, Sylvia, Legat, Franz J., Muellegger, Robert, Reider, Norbert, Schmuth, Matthias, Hintner, Helmut, Hofer, Angelika, Gruber-wackernagel, Alexandra, Aberer, Werner, Quehenberger, Franz, Wolf, Peter,
 ACTA DERMATO-VENEREOLOGICA: 2016; 96: S. 207-212

A Single Quantifiable Viral Load Is Predictive of Virological Failure in Human Immunodeficiency Virus (HIV)-Infected Patients on Combination Antiretroviral Therapy: The Austrian HIV Cohort Study

Leierer, Gisela, Grabmeier-Pfistershammer, Katharina, Steuer, Andrea, Sarcletti, Mario, Geit, Maria, Haas, Bernhard, Taylor, Ninon, Kanatschnig, Manfred, Rappold, Michaela, Ledergerber, Bruno, Zangerle, Robert, Austrian HIV Cohort Study Grp,
 OPEN FORUM INFECTIOUS DISEASES: 2016; 3: S.

Impact of low-level viremia on clinical and virological outcomes in treated HIV-1-infected patients

Vandenhende, Marie-Anne, Ingle, Suzanne, May, Margaret, Chene, Genevieve, Zangerle, Robert, et al. and Antiretroviral Therapy Cohort,
 AIDS: 2015; 29: S. 373-383

Mortality According to CD4 Count at Start of Combination Antiretroviral Therapy Among HIV-infected Patients Followed for up to 15 Years After Start of Treatment: Collaborative Cohort Study

May, Margaret T., Vehreschild, Jorg-Janne, Trickey, Adam, Obel, Niels, Reiss, Peter, Bonnet, Fabrice, Mary-Krause, Murielle, Samji, Hasina, Cavassini, Matthias, Gill, Michael John, Shepherd, Leah C., Crane, Heidi M., Monforte, Antonella d'Arminio, Burkholder, Greer A., Johnson, Margaret M., Sobrino-Vegas, Paz, Domingo, Pere, Zangerle, Robert, Justice, Amy C., Sterling, Timothy R., Miro, Jose M., Sterne, Jonathan A. C., Antiretroviral Therapy Cohort,
 CLINICAL INFECTIOUS DISEASES: 2016; 62: S. 1571-1577

Selected Funding

- **Control of epidermal eicosanoid metabolism and barrier function by PPARs.**
 Sandrine Dubrac, FWF P28039, 2015-2018, € 268.000.
- **Effects of allergenic lipocalins on dendritic cells.**
 Christine Heufler, FWF P27543, 2015-2018, € 348.000.
- **Langerhans cells and Natural Killer cells in the immune surveillance of cancer.**
 Daniela Ortner-Tobider, FWF T737 Hertha-Firnberg, 2015-2018, € 224.000.
- **EU Training Network for the Immunotherapy of Cancer: Dendritic cell-based immunotherapy: antibody-mediated targeting of dendritic cells in vivo through the skin.**
 Patrizia Stoitzner, EU IMMUTRAIN, 2016-2019, € 256.000.

Collaborations

- Universitäts Hautklinik, Wien (Profs. Georg Stingl, Adelheid Elbe-Bürger, Erwin Tschachler)
- Universitäts Hautklinik, Erlangen (Prof. Gerold Schuler)
- Laboratory of Cellular Physiology & Immunology, The Rockefeller University, NY (Prof. Michel Nussenzweig)
- Stanford University (Assoc. Prof. Juliana Idoyaga)
- The Malaghan Institute for Medical Research, Wellington, NZ (Prof. Franca Ronchese)
- Johannes Gutenberg Universität Mainz (Prof. Björn Clausen)
- University of California at San Francisco (Profs. Peter Elias, Ken Feingold)
- Université de Strasbourg, Frankreich (Dr. Vincent Flacher)
- Universität Zürich, Schweiz (Prof. Christian Münz)
- Max Planck Institute of Colloids and Interfaces, Potsdam (Dr. Christoph Rademacher)

Ophthalmology and Optometry



Director:
Univ.-Prof. Dr. Dr.h.c. Nikolaos Bechrakis

Contact:
Anichstraße 35
6020 Innsbruck

Nikolaos.Bechrakis@i-med.ac.at
Phone: +43 512 504 23720
Fax: +43 512 504 23722
<https://augenklinik.tirol-kliniken.at>

Research Branch (ÖSTAT Classification)

301101, 301103, 301107,
302055, 302080

Keywords

Ophthalmic oncology, vitreoretinal surgery, retinal diseases, cornea, conjunctiva, neovascularization, age-related macular degeneration, glaucoma

Research Focus

Major research topics include diagnosis and management of tumors of the eye, development of novel vitreoretinal surgical techniques as well as vitrectomy fluidics research, basic angiogenesis research and its suppression in an animal model, clinical research of retinal, corneal and eye surface pathology as well as glaucoma research. Special emphasis is given to development of new diagnostic methods in various aspects of epi- and intraocular diseases.

General Facts

Both basic as well as clinically-oriented research is performed at the Department of Ophthalmology/Medical University of Innsbruck. There are several clinically-oriented research projects described below, for basic research a laboratory is available which is appropriately equipped to perform science of high quality. Two medical technicians are employed, one responsible for the cornea bank, and the other for performance of the methods of the research groups. Both *in vitro* as well as *in vivo* methods are established in the laboratory; the *in vitro* methods include special migration and pro-

liferation assays for certain cells. We work with different cell-lines: (1) *cryo*-preserved retinal pigment epithelial cells to study the significance of the pathogenesis of proliferative vitreoretinopathy using migration and proliferation assays; (2) *choroidal* endothelial cells have been isolated and cultured from pig eyes, migration and proliferation assays serve to obtain a better understanding of the pathogenesis of wet age-related macular degeneration; (3) retinal endothelial cells are cultured, the performance of these assays is important for understanding the pathogenesis of proliferative diabetic retinopathy. For the *in vivo* experiments, a PhD student has been employed by means of an accepted grant proposal from the "Fonds zur Förderung der wissenschaftlichen Forschung" (FWF) (principle investigator: Prof. NE Bechrakis; title: VEGF and neuropeptides in experimental choroidal neovascularization; P 26356-B23). The aim of the Head of this research unit is to always create an additional position for the laboratory of this research institution, either a PhD student or a PostDoc. There are both international as well as national scientific cooperations present to improve the quality of this research unit. Collaborations exist with Prof. Peng Loh (Bethesda, USA), Prof. D. Weber (PSI, Villigen, CH), Prof. S. Kaye (Liverpool, UK), Dr. O. Gramlich (Dept. of Ophthalmology and Visual Sciences, Iowa City, USA), Prof. Christian Humpel, Prof. Reiner Fischer-Colbrie and Prof. Rudolf Kirchmair (from the Medical University of Innsbruck).

Research

Quality Assurance in Ophthalmology

The Department of Ophthalmology at the

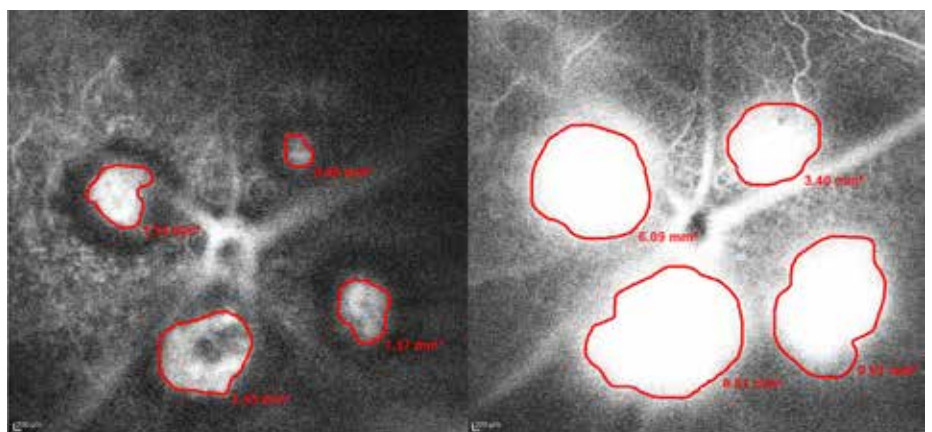

Fig. 1: *In vivo* fluorescein angiography of the posterior pole of the mouse retina after laser induction of choroidal neovascularization. Early phase (left) and late phase leakage (right). The leakage areas are measured and quantified. Cumulative leakage is documented in the late fluorescein stages.

Medical University of Innsbruck is committed to quality management programs based explicitly on continuous quality improvement and continuous quality control. Since 2013 a risk management system has been implemented in the Department. Two have recently been added additionally:

- **Macular Pucker Registry**

Kralinger, Bechrakis

Austrian Multi Centre quality management project in the surgical management of Macular pucker where more than 300 cases were analyzed.

- **Retinal Detachment Registry**

Zehetner, Bechrakis

Implementation of a Retina detachment Register Innsbruck to analyze and evaluate outcomes in retinal detachment surgery. This project is integrated in the implementation of electronic patient files both for out- (established in 2015) as well as for inpatient records (established in 2016).

Vitreotomy Fluidics

Zehetner, Bechrakis

The goal of all vitreous surgery is to perform the desired intraoperative intervention with minimum collateral damage in the most efficient way possible. An understanding of the principles of fluidics is of pivotal scientific importance. Fluidic stability is a main principle of vitrectomy within a closed system. The flow rate of a Newtonian fluid through a vitrectomy probe can be described by Poiseuille's law, but the flow of the aspirated material during vitrectomy is more complex to characterize. Viscous material increases the resistance of flow through the vitrectomy probe and due to the constantly changing outflow the inflow of balanced salt solution (BSS) must be continuously adjusted. The objectives of our study group are *in-vitro* analyses of physical parameters related to vitreous surgery utilizing high-speed cutting 23-, 25- and 27-gauge (G) vitrectomy probes. These results provide information to surgeons about how small gauge probe size and new double-cutting vitrectome designs may affect the efficiency of bulk core vitreous removal as well as safety during shaving of the vitreous base. These laboratory parameters influence the choice of vitrectomy instrumentation and the intraoperative safety of the respective surgical techniques.

Anti-VEGF Therapy in AMD and DR

Zehetner, Bechrakis

Neovascular age-related macular degen-

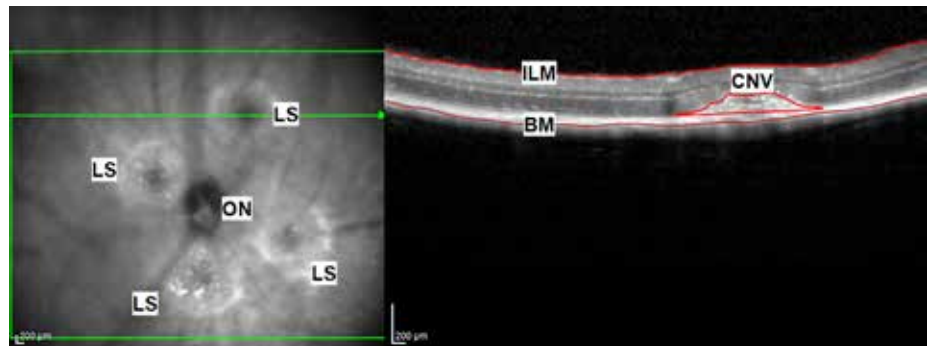

Fig. 2: In vivo examination of laser induced choroidal neovascularization in the mouse model. The left figure shows an infrared en face image of the posterior pole of the mouse retina and the right image shows the in vivo optical coherence tomography (OCT) of one choroidal neovascularization spot.

eration (AMD) and diabetic retinopathy (DR) are the leading causes of visual loss in ageing western populations. The current standard of care involves intravitreal administration of monoclonal antibody-based therapies directed against VEGF (Vascular Endothelial Growth Factor). VEGF is a multifunctional cytokine that regulates antiapoptotic pathways of endothelial cells in adult vasculature. Systemic VEGF acts as a vascular protective factor and is essential for maintaining the integrity and the anti-thrombogenic as well as anti-inflammatory properties of the endothelium. Our study group could demonstrate that intraocular application of VEGF inhibitors can induce a significant reduction of systemic VEGF. Our study results are of translational relevance in regards to clinical safety. Sustained reduction of systemic VEGF in general circulation is an inadvertent off-target effect that might increase the incidence of cardiovascular anti-VEGF class effects. The selective therapeutic interference with factors of the proangiogenic signalling circuit for the treatment of pathologic neovascularization is likely to result in compensatory increases of other factors involved in this process. This could induce converse regulatory effects that might weaken the therapeutic efficacy of antiangiogenic drugs. Our study group found a significant systemic upregulation of the proangiogenic cytokine PIGF (Placental Growth Factor) after intravitreal administration of VEGF inhibitors. Secondary alterations of proangiogenic factors could potentially promote an escape from angiogenesis inhibition and may be responsible for the decreased therapeutic efficacy or persistence of the neovascular tissue in patients undergoing intravitreal antiangiogenic therapy. Identification of factors that confer antiangiogenic drug resistance would enable development of the

next generation of drugs for more effective treatment of ocular vasculopathies. PD Dr. Zehetner was awarded two prizes for his excellent scientific work.

Diagnostics in Ophthalmology

Blatsios, Bechrakis

There are four projects in progress on this topic. Firstly, a descriptive evaluation of the characteristics of choroidal melanomas pre- and post-irradiation therapy using the laser imaging system OPTOMAP® is performed. Secondly, we aim to explore the clinical assessment and ultrasound biomicroscopic evaluation of sclera fixated intraocular lenses. Next, a clinical assessment and ultrasound biomicroscopic evaluation of sclera fixated toric intraocular lens will also be performed, and finally, there is a joint project with the Department of Physics and Institute of Theoretical and Computational Physics at the University of Crete, where the fundamental principle of using quantum biometrics in retinal perception for subject identification should be described.

N-Chlorotaurin Treatment and XEN 45 Gel Stent Implantation

Teuchner

PD Dr. Teuchner works on two topics: On the one hand, the efficacy of N-Chlorotaurin against candida albicans was investigated in an *ex vivo* corneal infection model which provided evidence of a strong microbicidal effect; this could enable clinical use of this agent in infectious keratitis. On the other hand, explorations on XEN 45 Gel Stent implantations were performed. The XEN 45 Gel Stent is an FDA approved device which is implanted through an ab interno approach and reduces the intraocular pressure (IOP) by creating a drainage channel between the anterior chamber and the subconjunctival space. It is considered

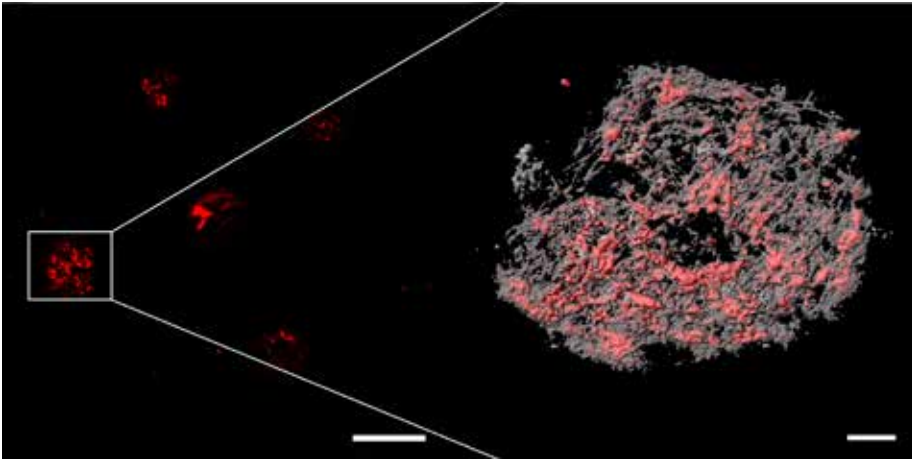

Fig. 3: Confocal image of a sclerochoroidal flatmount (*ex vivo*) with four choroidal neovascularization spots visible (left line corresponds to 200 µm). The right Figure shows an enlarged image of one of the four choroidal neovascular membranes with capillaries depicted in red (left line corresponds to 50 µm).

a minimal invasive glaucoma surgery procedure as the collagen stent is placed with an injector through a 2mm small clear cornea incision into the angle of the anterior chamber. As a result, the Stent showed an up to 50% drop of IOP in the early post-operative phase and no severe intra or post-operative complications; the long term results are under investigation.

Ocular Surface Imaging Group

Steger, Palme, Seifarth

The “Ocular Surface Imaging Group” is focusing on innovative diagnostic methods to quantitatively and qualitatively assess the corneal and conjunctival inflammatory response. Several articles were published in 2016 including a) the use of anterior segment optical coherence tomography (AS-OCT) to describe anterior stromal scarring associated with pterygium; b) the use of ocular surface fluorescence angiography to quantify corneal neovascularization (CoNV), to describe the architecture and origin of CoNV, to guide the selective arteriolar fine needle diathermy of CoNV, and to assess conjunctival inflammation in atopic keratoconjunctivitis; c) the use of *in vivo* confocal microscopy to describe a novel inherited corneal dystrophy and to assess corneal stromal postoperative tissue remodelling after femtosecond laser anterior lamellar keratectomy for the treatment of corneal stromal dystrophies; d) the use of optical coherence tomography to aid in lamellar keratoplasty.

While finishing these projects, the described imaging techniques are currently applied in

a clinical study to describe vascular and *in-vivo* confocal microscopic changes in ocular surface neoplastic lesions (OSN) including squamous cell carcinoma, conjunctival naevi, and malignant melanoma, with the aim to identify characteristics with high diagnostic sensitivity and specificity to improve non-invasive diagnostic assessment of OSN.

Diagnosis and Treatment of Intraocular Tumors

Haas, Blatsios, Zehetner, Bechrakis

We are the only Department of Ophthalmology in Austria which has established proton beam irradiation for intraocular tumors. This treatment modality is performed in collaboration with the Paul-Scherer Institute (PSI) in Villigen/CH.

The treatment is prospectively monitored for metastatic incidence, eye and visual acuity preservation, as well as radiation induced side-effects. Typical features of choroidal melanomas after proton therapy using the OPTOMAP® imaging system are evaluated (see also above). Secondly, tumour specimens are processed for analysis with various stains of melanocytic markers (HMB-45, Melan-A) to identify the type, histological tumour location and biological characteristics. Furthermore, cytogenetic aberrations are analysed in cooperation with the Department of Human Genetics (Medical University of Innsbruck) including immunohistochemical BAP-1 (tumour suppressor gene) mutation detection, which should allow conclusions on prognosis and estimation of survival (established in the

Ophthalmic Pathology Lab of the Department of Ophthalmology). Finally, treatment outcomes of various therapeutic modalities of intraocular tumors are analysed, especially in uveal melanoma. In cooperation with the Department of Ophthalmology (Medical University of Graz), treatment with photodynamic therapy or intravitreal anti-VEGF therapy are compared in choroidal naevi with secondary choroidal neovascularization. Treatment outcomes are analysed as well in choroidal hemangiomas both by proton beam radiotherapy or by photodynamic therapy.

Neuropeptide Research

Nowosielski, Troger, Bechrakis

There is evidence that certain neuropeptides act in a proangiogenic manner and thus may contribute to abnormal neovascularizations in the eye. This might be the case for choroidal neovascularisations in wet age-related macular degeneration and also for retinal neovascularisations in proliferative diabetic retinopathy. As a first step, the involvement of the neuropeptides substance P, neuropeptide Y and secretoneurin are currently investigated in laser-induced choroidal neovascularization (funded by the FWF). The induction of choroidal neovascularizations due to laser treatment represents a well-established animal model and the formation of neovascular membranes is analysed by different methods. The involvement of these peptides is explored by the performance of experiments not only in certain knock out mice but also by intravitreal injections of receptor antagonists in mice. The results of these experiments will hopefully provide novel treatment strategies in wet age-related macular degeneration. In the future, the involvement of these peptides should be explored also in a mouse model of proliferative diabetic retinopathy. Another aim of this research group is to investigate the presence and distribution of granin-derived peptides in the rat eye, in particular of the serpinins, vasostatin and of secretolytin and pancreastatin. Furthermore, the source of these peptide-containing nerves must be explored, namely by determination of their sympathetic, parasympathetic or sensory origin.

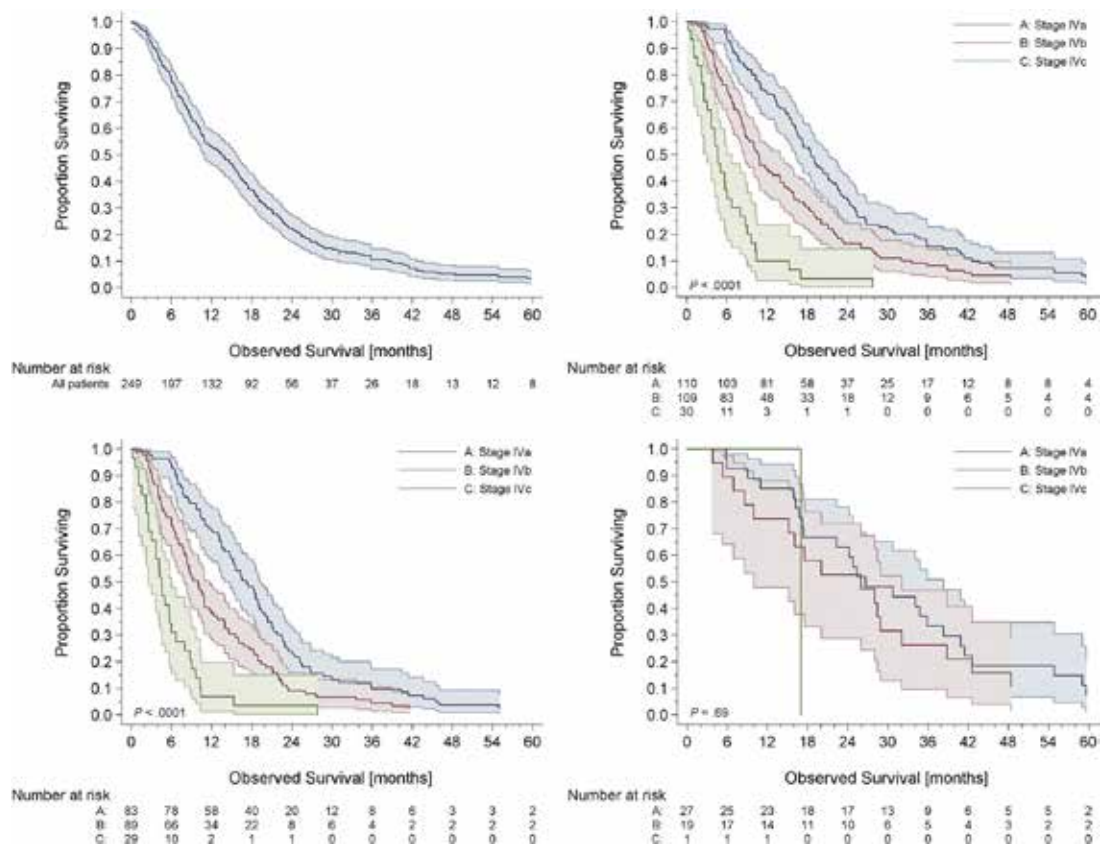

©American Journal of Ophthalmology, 2016

Fig. 4: Kaplan-Meier survival curves displaying overall survival after diagnosis of metastatic uveal melanoma in 249 patients in the entire validation dataset (Top left); according to the Helsinki University Hospital Working Formulation for all patients (Top right); and for patients managed without surgery (Bottom left) and with surgery (Bottom right). Numbers below graphs are patients at risk and shaded ranges are 95% confidence intervals. Note that the intervals completely overlap when surgery was part of the treatment of metastases.

Selected Publications

Neoadjuvant proton beam irradiation followed by transcleral resection of uveal melanoma in 106 cases
 Willerding, Gregor D., Cordini, Dino, Moser, Lutz, Krause, Lothar, Foerster, Michael H., Bechrakis, Nikolaos E.,
 BRITISH JOURNAL OF OPHTHALMOLOGY: 2016; 100: S. 463-467

Validation of a Prognostic Staging for Metastatic Uveal Melanoma: A Collaborative Study of the European Ophthalmic Oncology Group
 Kivela, Tero T., Piperno-Neumann, Sophie, Desjardins, Laurence, Schmittl, Alexander, Bechrakis, Nikolaos, Midea, Edoardo, Leyvraz, Serge, Zografos, Leonidas, Grange, Jean-Daniel, Ract-Madoux, Guillaume, Marshall, Ernest, Damato, Bertil, Eskelin, Sebastian,
 AMERICAN JOURNAL OF OPHTHALMOLOGY: 2016; 168: S. 217-226

Detection of tumour cells in the bloodstream of patients with uveal melanoma: influence of surgical manipulation on the dissemination of tumour cells in the bloodstream
 Charitoudis, Georgios, Schuster, Ronny, Jousen, Antonia M., Keilholz, Ulrich, Bechrakis, Nikolaos E.,
 BRITISH JOURNAL OF OPHTHALMOLOGY: 2016; 100: S. 468-472

Sequential Bilateral Corneal Transplantation and Graft Survival
 Steger, Bernhard, Curnow, Elinor, Cheeseman, Robert, Romano, Vito, Kaye, Abigail, Jones, Mark, Kaye, Stephen, Natl Hlth Serv Blood, Transplant Ocular Tissue Advisory, Contributing Ophthalmologists OTAG,
 AMERICAN JOURNAL OF OPHTHALMOLOGY: 2016; 170: S. 50-57

Systemic Counterregulatory Response of Placental Growth Factor Levels to Intravitreal Aflibercept Therapy
 Zehetner, Claus, Bechrakis, Nikolaos E., Stattin, Martin, Kirchmair, Rudolf, Ulmer, Hanno, Kralinger, Martina T., Kieselbach, Gerhard F.,
 INVESTIGATIVE OPHTHALMOLOGY & VISUAL SCIENCE: 2015; 56: S. 3279-3286

Systemic levels of vascular endothelial growth factor before and after intravitreal injection of aflibercept or ranibizumab in patients with age-related macular degeneration: a randomised, prospective trial
 Zehetner, Claus, Kralinger, Martina T., Modi, Yasha S., Walli, Inga, Ulmer, Hanno, Kirchmair, Rudolf, Bechrakis, Nikolaos E., Kieselbach, Gerhard F.,
 ACTA OPHTHALMOLOGICA: 2015; 93: S. E154-E159

Selected Funding

VEGF and neuropeptides in experimental choroidal neovascularization; P 26356-B23, FWF-Grant, Prof. Dr. Dr.h.c. NE Bechrakis

Collaborations

- Section of Cellular Neurobiology, Bethesda, USA
- Dept. of Ophthalmology and Visual Sciences, Iowa City, USA
- Paul Scherer Institute (PSI) Villigen, CH
- Department of Ophthalmology, Medical University Graz, A
- St. Pauls Eye Unit, Liverpool, UK

Women's Health Center



Director:
Univ.-Prof.ⁱⁿ Dr.ⁱⁿ
Margarethe Hochleitner

Contact:
Innrain 66 / 1st floor
6020 Innsbruck

Margarethe.Hochleitner@i-med.ac.at
Phone: +43 512 504 25710
Fax: +43 512 504 25719
<http://fgz.i-med.ac.at/>

Research Branch (ÖSTAT Classification)

305902, 504013, 504014

Keywords

Gender medicine, women's health, lifelong learning, prevention, affirmative action for women, work-life-balance

Research Focus

- How to get Gender Medicine into the Medical Curricula?
- How to get Gender Medicine into the Clinic?
- Gender Medicine and Prevention, Cardiology
- Women's Empowerment, Women's Careers, Work-Life-Balance
- Diversity, Migration
- How to deal with Sex and Violence in a Medical Setting?

General Facts

The Gender Medicine Unit includes a Women's Health Outpatient Clinic focussing on all Women's Health issues. It is a routing station within the University Hospitals. There is a special focus on migrant women. The Women's Health Clinic consists of an outpatient clinic, but there is also a lot of activity outside the hospital, like awareness campaigns and talks for women's organisations.

Beside the Women's Health Outpatient Clinic there is a research institute. This research institute focuses on research on Gender Medicine and related topics. One main topic is the implementation of Gender Medicine into the curricula of all health professions.

At the Medical University of Innsbruck we provide courses on Gender Medicine in human medicine, dental medicine and molecular medicine, and in addition we also teach at the Fachhochschule Gesundheit (for midwives and all technical-medical professions) and the school of nurses (AZW).

Our research work focuses also on migration. We carry out numerous surveys with our migrant medical students, mainly the Turkish ones, and also with our Turkish patients. Recently we also conducted studies on German medical students studying at the Medical University of Innsbruck.

Another focus is on sex and violence. We developed a history-taking questionnaire including aspects of sex and violence, approved by the Ethical Commission for our patients at the Women's Health Clinic and the midwives. The aim is to implement our paper into everyday clinical practice.

We work on numerous Women's issues and are very pleased to have implemented Gender aspects in research topics, from basic to clinical science.



Ring Lecture Series Gender Medicine



Ring Lecture Series Gender Medicine

Research

Implementation of Gender Medicine into the Curricula

After completion of the EuGiM project on Lifelong Learning which developed Gender Medicine curricula for implementation into master studies and summer schools there is now a follow-up project EuGenMed "Roadmap for a gender-sensitive approach to health care research and practice in Europe". The "Innsbruck Model" of integration of sex and gender in the different curricula was cited as example of best practice. Additionally, various talks were held, e.g. at the Claudiana, Bozen/South Tyrol, to inform about possibilities of implementing Gender Medicine in the curricula.

Migration

We launched numerous questionnaires with Austrian, German and Turkish medical students. The questionnaire asks for their study situation, problems and barriers, but also for their perception of sex and gender. Additionally, focus groups with Austrian and Turkish medical students were conducted to get in-depth knowledge on specific barriers and resources of medical students. We also analyse sex and gender differences within these groups. A PhD-student and a post-doc are working on this topic.

Sex and Violence

We developed a questionnaire for patients on sex and violence and started working with it at our Women's Health Outpatient Clinic. Now we work with the midwives and their patients. Additionally we initiated a project including questions to men about sexuality and violence, aiming to include their experiences and needs in this topic. Our aim is to develop a questionnaire for all patients at all clinics that is accepted not only by patients but also by the providers, i.e. doctors. Furthermore, projects with midwifery students (Master level) are planned to facilitate inclusion and implementation of this topic in everyday practice. Additionally we started to investigate experiences of discrimination, mistreatment and violence among employees and students. Two medical students also included this topic in their diploma theses.

There is also a PhD-student and a post-doc working on the topic of sexuality and violence.

Selected Publications

Support for Female Physicians at a University Hospital: What Do Differences Between Female and Male Physicians Tell Us?

Siller, Heidi, Bader, Angelika, Hochleitner, Margarethe
In Roxane L. Gervais & M. Prudence M. Millea (Eds.), Exploring Resources, Life-Balance and Well-Being of Women Who Work in a Global Context Cham: Springer International Publishing. 2016, S. 109-123.

Drafting intersections in the career of female medical doctors.

Siller, Heidi, Hochleitner, Margarethe
In: Tsouroufli Maria, editor. Gender, Careers and Inequalities in Medicine and Medical Education: International perspectives. UK: Emerald Group Publishing Limited; 2015: S. 99-125

Turkish Migrant Women with Recurrent Depression: Results from Community-based Self-help Groups

Siller, Heidi, Renner, Walter, Juen, Barbara.
BEHAVIORAL MEDICINE, 0., 2015; doi: 10.1080/08964289.2015.1111858

Dichotomien in der interpersonellen Gewalt unter Berücksichtigung einer Genderperspektive

Siller, Heidi, Hochleitner, Margarethe
JURIDIKUM, 4, 2015: S. 505-515.

Collaborations

- Univ.-Prof.in Dr.in Vera Regitz-Zagrosek, Charité, GiM, Berlin/Germany
- Univ.-Prof.in Dr.in Karin Schenck-Gustafsson, Karolinska, Stockholm/Sweden
- Univ.-Prof. in Dr. in Bettina Pfeleiderer, Universität Münster
- Assoc.-Prof.in Dr.in Petra Verdonk, Amsterdam Medical Centre, Amsterdam/Netherlands
- Univ.-Prof.in Dr.in Ineke Klinge, Maastricht University, Maastricht/Netherlands
- Univ.-Prof.in Dr.in Alexandra Kautzky-Willer, MUW, Internal Medicine, Vienna/Austria
- Univ.-Ass.in Dr.in Caroline Voithofer, Leopold Franzens Universität, Zivilrecht, Innsbruck/Austria
- Priv.-Doz.in Dr.in Susanne Perkhofer, FH gesundheit, Innsbruck/Austria
- Dr.in Waltraud Buchberger MSc, AZW, Innsbruck/Austria
- ao. Univ.-Prof.in Dr.in Barbara Juen, Leopold Franzens Universität, Institute for Psychology, Innsbruck/Austria
- Prof.in Dr.in Patricia Davidson, Johns Hopkins University, Dean of the School of Nursing, Baltimore/USA
- FH Gesundheit - Zentrum für Gesundheitsberufe Tirol GmbH
- AZW-Ausbildungszentrum West Gesundheitsberufe der Tirol Kliniken GmbH

Neuroscience



Director:
Univ.-Prof. Dr. Georg Dechant

Contact:
Innrain 66/G3
6020 Innsbruck

Georg.Dechant@i-med.ac.at
Phone: +43 512 504 27297
Fax: +43 512 504 27390
www.i-med.ac.at/neuroscience

Research Branch (ÖSTAT Classification)
301402, 301114, 304003, 304007

Keywords

Neuronal plasticity, neurotrophic factors, cell signalling, transgenic animal models, induced pluripotent stem cells, neuronal differentiation, human models of neurological diseases

Research Focus

Our laboratory studies how nerve cells can be programmed and re-programmed depending on neural activity and neurotrophic growth factors. In transgenic mouse models we investigate activity-dependent mechanisms of learning and memory that depend on plastic chromatin reorganisation in the cell nucleus. Another focus is to generate neurons from stem cells. We are developing protocols to differentiate human stem cells obtained with the "induced pluripotent stem cell" (iPSC) technology into specific neuronal populations. Based on these protocols we have established cellular models of human neurological diseases.

General Facts

The Institute for Neuroscience is located on the third floor of the building at Innrain 66 in close vicinity to laboratories of Psychiatry, Neurology and Neurosurgery. Members of the Institute participate in the FWF-funded networks SFB-F44 and DK 106 SPIN. The Institute offers modern infrastructure and state-of-the-art research equipment. Laboratories include a stem cell laboratory licensed for biosafety level 2 work dedicated to generation and differentiation of human iPSCs. Procedures have been implemented to generate, stably maintain and differentiate human iPSC-derived cell lines. Separate laboratory rooms are dedicated to work with nucleic acids and proteins. In addition, the Institute supports a primary cell culture and animal transplantation laboratory. Rooms are fully-equipped with stereomicroscopes, epifluorescence and confocal microscopes and a specialised room is dedicated to histology, sectioning and immunostaining.

Research

Neuronal Plasticity Group

Dr. Galina Apostolova

Modulation of Higher-Order Chromatin Architecture - Implications for Neuronal Plasticity

Complex behaviours such as learning and memory depend on changes in gene expression and subsequent long-lasting adaptations in synaptic strength and structure. Our current research interests are focused on the mechanisms of neuronal plasticity, with a special emphasis on the role of chromatin conformation regulation in adaptive gene transcription.

A classic example of neuronal plasticity is the switch from noradrenergic to cholinergic

neurotransmission, which occurs in differentiated postganglionic sympathetic neurons under the influence of target-derived signals. We identified the genome organiser Special AT-rich sequence binding protein 2 (Satb2) as an acutely up-regulated target gene of neurokinine/p38 MAPK signalling in sympathetic neurons undergoing trans-differentiation. Our gain-and loss-of-function studies revealed that Satb2 is both necessary and sufficient to trigger the sympathetic neurotransmitter switch. We reasoned that modulation of Satb2 and consequently chromatin architecture by neurotrophic factors might serve as a novel pathway involved in the long-term adaptive processes underlying higher brain functions.

In support of this hypothesis, recent results in our laboratory showed that Satb2 is induced by plasticity-mediating extracellular signals such as BDNF or Ca²⁺-influx through L-type voltage-gated calcium channels in CNS neurons. The analysis of a conditional mutant lacking Satb2 in the adult forebrain (generated by our group), demonstrated that Satb2 is required for synaptic plasticity and long-term memory formation. In addition, we found that Satb2 interacts with genome organising proteins of the inner nuclear membrane and regulates the geometry of neuronal nuclei in the hippocampus *in vivo*. Our findings give us grounds to hypothesise that a Satb2-containing DNA-protein complex determines both the nuclear shape and chromosomal conformations in neurons downstream of L-VGCC and BDNF signalling, thereby integrating plasticity-mediating extracellular signals into changes in the transcriptome. Our future goals are to provide evidence that Satb2-dependent rearrangements of the nuclear architecture and/or changes in the epigenetic profiles are necessary for

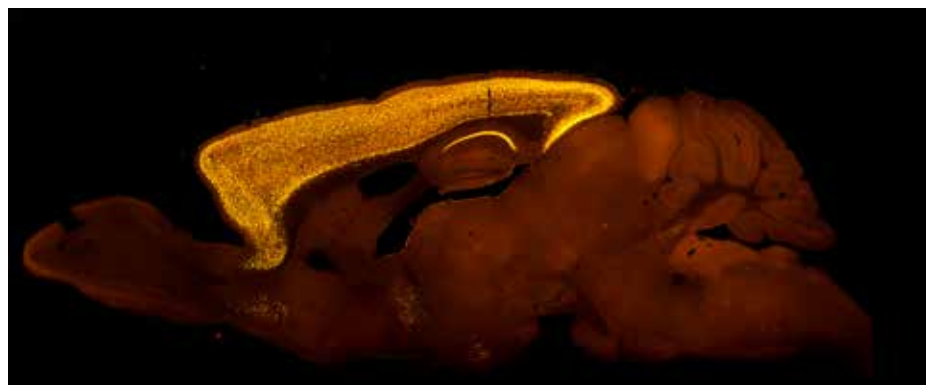

Fig. 1: Immunostaining for Satb2 in sagittal mouse brain sections reveals strong Satb2 expression in the cortex and CA1 area of the hippocampus.

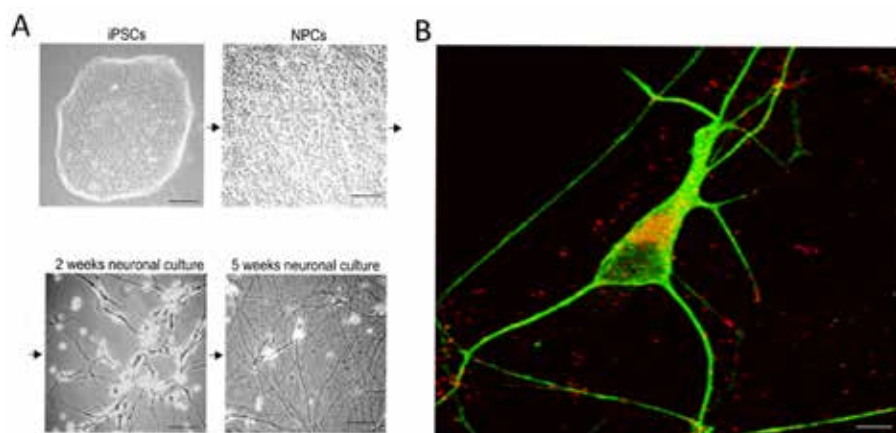

Fig. 2: (A) Neurons from Spinocerebellar Ataxia type 6 (SCA6) patients are generated via differentiation of induced pluripotent stem cells (iPSCs) and neural progenitor cells (NPCs) (phase-contrast microscopy, scale bars: 75 μ m). (B) human neuron expresses CaV2.1 channel protein (red) and MAP2 (green). Immunocytochemistry after 5 weeks of neuronal culture (confocal microscopy, scale bar: 10 μ m).

higher cognitive functions and that dysfunction of these mechanisms leads to learning and memory deficits. We also aim to study whether cognitive deficits inherent to normal ageing and neuropsychiatric diseases are caused by alterations in *Satb2* expression or function.

Stem Cells and Neural Differentiation Group

PD Dr. Roxana Nat

The availability of human-induced pluripotent stem cells (iPSCs) and human embryonic stem cells (hESCs) provides a unique opportunity to investigate the mechanisms of human nervous system development and its disorders. There are currently two major areas of interest:

- 1) To explore the molecular mechanisms that regulate PSC conversion into specific neural progenitor populations, their neuronal subtype specification and functional maturation. To this end, develop and apply protocols for neural induction, patterning and specification to human PSCs based on knowledge of nervous system development.
- 2) To model human neurological disorders with iPSC derivatives in order to understand the molecular pathomechanisms. We reprogram patient-derived somatic cells into iPSC lines, which are then differentiated into disease-relevant neurons. Currently, our efforts are focussed on two monogenic neurological diseases.

Friedreich Ataxia

Friedreich Ataxia (FRDA) is an autosomal recessive neurodegenerative disease caused by an elongated intronic GAA repeat in the gene encoding the mitochondrial protein frataxin. Peripheral sensory neurons are the most susceptible cells for FRDA pathophysiology. Animal models of FRDA reproduced GAA repeat expansion, frataxin deficiency, mitochondrial alterations and neurodegeneration observed for the human disease, but the central questions concerning FRDA pathophysiology remained elusive: why are specific neuronal populations particularly susceptible to FRDA and when during ontogeny does the pathology manifest in susceptible neurons? To address these questions, we have generated patient iPSC lines and differentiated them to peripheral sensory neurons (Eigentler et al 2013). Mitochondrial functions and cell death are compared during *in vitro* maturation of control and FRDA iPSC-derived sensory neurons. Furthermore, we analyse whether the frataxin deficit affects the peripheral sensory neurons after their transplantation in chicken embryos.

Spinocerebellar Ataxia Type 6

Spinocerebellar Ataxia type 6 (SCA6) is an autosomal dominant neurodegenerative disease associated with the *CACNA1A* gene, coding for the $\alpha 1A$ subunit of P/Q type voltage-gated calcium channel CaV2.1. SCA6 mutation consists of CAG repeats leading to a short expansion of a polyglutamine stretch located in the cytoplasmic C-terminal tail of the channel protein. Currently, the pathogenic mechanisms

remain elusive, and no therapy is known. We generated iPSC lines from SCA6 patients and differentiated them in neurons. We are currently investigating the subcellular localisation of CaV2.1 channel protein and neuronal excitability, calcium currents and synaptic transmission in SCA6 neurons.

Selected Publications

Satb2 determines miRNA expression and long-term memory in the adult central nervous system
Jaitner, Clemens, Reddy, Chethan, Abentung, Andreas, Whittle, Nigel, Rieder, Dietmar, Delekate, Andrea, Korte, Martin, Jain, Gaurav, Fischer, Andre, Sananbenesi, Farahnaz, Cera, Isabella, Singewald, Nicolas, Dechant, Georg, Apostolova, Galina, ELIFE: 2016; 5: S. e17361

Reduced Anxiety-Like Behavior and Altered Hippocampal Morphology in Female *p75NTR(exon) IV^{-/-}* Mice
Puschban, Zoe, Sah, Anupam, Grutsch, Isabella, Singewald, Nicolas, Dechant, Georg, FRONTIERS IN BEHAVIORAL NEUROSCIENCE: 2016; 10: S. 103

Alternative Generation of CNS Neural Stem Cells and PNS Derivatives from Neural Crest-Derived Peripheral Stem Cells
Weber, Marlen, Apostolova, Galina, Widera, Darius, Mittelbronn, Michel, Dechant, Georg, Kaltschmidt, Barbara, Rohrer, Hermann, STEM CELLS: 2015; 33: S. 574-588

Selected Funding

- 2013-2016 FWF DK W1206 "Signal Processing in Neurons" Dechant
- 2013-2016 FWF Stand-alone project P25014-B24 "Role of genome organizer *Satb2* in adult brain function" Apostolova
- 2015-2019 FWF SFB-F44 "Cell Signaling in Chronic CNS Disorders" Apostolova, Dechant
- 2014-2016 FWF Standalone Project Nr P 26886-B19, "Modeling Friedreich Ataxia with patient iPSC-derived neurons", Nat

Collaborations

- Roland Foisner, Medical University Vienna; Vienna, Austria
- Marin Korte; TU Braunschweig, Braunschweig; Germany
- Nicolas Singewald; Innsbruck University, Innsbruck; Austria
- Andre Fischer, German Center for Neurodegenerative Diseases, Göttingen Germany



FWF-funded Programmes

Doctoral Programmes (DK):

DK Molecular Cell Biology and Oncology – MCBO

DK Host Response in Opportunistic Infections – HOROS

DK Signal Processing in Neurons – SPIN

Special Research Programmes (SFB):

SFB-F44: Cell signaling in chronic CNS disorders

Molecular Cell Biology and Oncology



Speaker:
ao. Univ.-Prof. Dr.
Bernhard E. Flucher



Contact:

Biocenter, Innrain 80-82
6020 Innsbruck

mcbo@i-med.ac.at
Phone: +43 512 9003 70818
Fax: +43 512 9003 73836
www.mcbo.at

Research Branch (ÖSTAT Classification)

301110, 301114, 301206,
301902, 301904

Keywords

Doctoral research training, molecular cell biology, Austrian Science Fund (FWF) W1101

Research Focus

Research Training

- State-of-the-art PhD training in molecular cell biology and oncology
- Benchmark training standards: competitive recruitment, training opportunities, international exchange

FWF DK Program

The DK-Program by the Austrian Science Fund supports structured PhD programs at centers of excellence at Austrian universities. Programs are initiated by consortia of leading scientists and selected through a stringent international evaluation process. Programs are regularly reviewed and can be extended up to a total of 12 years.

General Facts

Molecular Cell Biology and Oncology (MCBO) is an excellence PhD program at the Medical University of Innsbruck funded by the FWF (Austrian Science Fund), with

participation from the University of Innsbruck. The goal of the MCBO doctoral program is to equip young researchers with the knowledge, skills and attitudes necessary to excel in an independent scientific career in basic and applied bio-medical sciences.

Training

Research training within MCBO is designed to prepare students for solving basic research questions and to teach in-depth knowledge of cell biology with the ultimate goal of creating the basis for the development of novel treatments to fight prevalent human diseases. To achieve this goal, MCBO is dedicated to providing its students with a multitude of state-of-the-art methodological skills, important basic knowledge in the field of cancer cell biology and tumor immunology, as well as with a set of complementary and transferrable skills required to perform front-line research. It is the main goal of MCBO to teach its students strategies that allow them to efficiently and successfully study features of a particular molecule or a specific signalling process at the subcellular or single-cell level, as well as in the context of an entire organism.

MCBO offers a comprehensive system of lectures and laboratory courses. Peer-reviewed research projects, dedicated supervision by three-member thesis committees and a lively seminar program create a stimulating research environment, conducive to the successful completion of the PhD.

Research Training

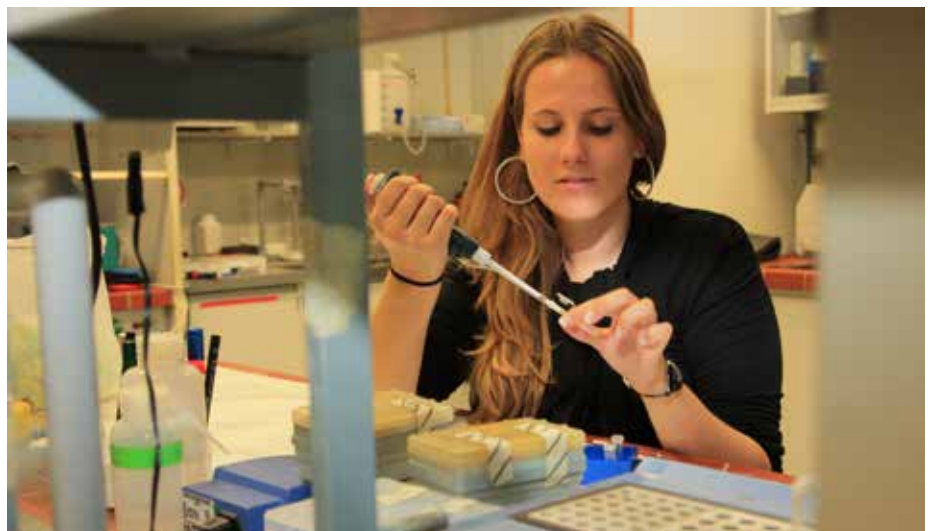



MCBO Team at mid-term retreat

Research

- Established in 2005
- 34 students enrolled
- 56 students graduated
- Students from 21 nations and 3 continents
- More than 180 publications
- Competitive recruitment
- Courses and lectures in English
- Three to four years thesis research
- International symposia and meetings
- Six-month stays abroad at prestigious universities like the University of California (San Francisco), John Hopkins University (Baltimore), Karolinska-Institut (Stockholm) and many more.

Funding

Austrian Science Fund (FWF):
 € 10.037.000
Medical University Innsbruck:
 € 3.365.000
University Innsbruck (LFU):
 € 250.000
Total:
 € 13.652.000



MCBO Students

HOROS - doctoral programme of excellence



Speaker:
ao. Univ.-Prof. DDr.
Reinhard Würzner

Contact:
Schöpfstrasse 41
6020 Innsbruck

Reinhard.Wuerzner@i-med.ac.at
Phone: +43 512 9003 70707
Fax: +43 512 9003 73700
www.horos.at

Research Branch (ÖSTAT Classification)

106023, 106024, 301902,
302020, 303020

Keywords

Host response, opportunistic infections, immunity, transplantation, biogerontology

Research Focus

Scientists and physicians of the Innsbruck campus working in the related fields of infection, immunity, transplantation and/or biogerontology decided to join forces and created a structured and multidisciplinary research and training programme of excellence (DK). Their intention is to investigate genetic and environmental parameters, which destroy immune homeostasis during host-pathogen interaction, thus leading to opportunistic infections. Such infections seldomly develop in healthy individuals but quite often in immuno-compromised subjects. The consortium originally consisted of 7 members (Prof. Kotsch has taken up a professorship in Berlin). Five of the remaining 6 members work at the Medical Uni-

versity of Innsbruck (MUI), one is heading the Institute of Biomedical Aging Research (IBA), now part of University of Innsbruck / Leopold Franzens University (LFU). It is envisaged to strengthen the cooperation between both local universities in the coming periods. Four members of the consortium are medical doctors - one works at bedside and 3 mainly preclinically - two are natural scientists. All 6 contribute to various aspects of host-pathogen interaction, comprising inherited and acquired immunity. On the infection side fungal, bacteriological or virological models are in use.

General Facts

From Basic Research to Clinical imentation

HOROS is carried out by scientists and physicians working in clinical departments or "pre-clinical" research institutes of both universities, thus providing an important translational link between basic research and clinical application. MUI is very interested to have a broad and excellent DK on "Infection, Immunity & Transplantation", one of its major officially stated research topics. A strong liaison with industrial partners has been established for supplementary funding. HOROS fosters even closer collaborations between research groups, the strategic added values lie in an attractive educational curriculum, more coherent and practical than previously. HOROS provides a perfect means to finance research stays of PhD students in collaborators' laboratories and a "HOROS annual retreat". Thus, HOROS strengthens the scientific environment of the research campus Innsbruck that attracts not only the best students, but also distinguished scientists to the campus.

Research

At present, 16 PhD students study in connection with HOROS. HOROS has organised a scientific retreat together with PhD students from Univ. of Copenhagen and has participated in the MUI Life Science Day, both in spring 2016. In 2017 HOROS is applying for a second and thus final four-year-period, which would start in March 2018. The projects of the HOROS faculty members are:

Identification of factor H binding complement evasion molecules in fungi

Ao.Univ.-Prof.DDr.Reinhard Würzner
(HOROS-Speaker, MUI)

Reinhard Würzner is an expert in complement evasion strategies, in particular of

bacteria and fungi, but also of complement related kidney diseases. He is the coordinating speaker of all MUI doctoral programmes and also head the related doctoral programme "Infectious Diseases".

The Role of the human Bone marrow in the regulation of immune responses in old age

Univ.-Prof.Dr.med.Beatrix Grubeck-Loebenstein (Deputy-Speaker, LFU)

Beatrix Grubeck-Loebenstein direct the Institute for Biomedical Aging Research (IBA) which is now part of LFU. She is a leading scientist in biogerontology and in particular in the immunology of old age and has inaugurated the related doctoral programme "Aging". Her contribution to HOROS will bridge the medical and science faculties of both universities.

Siderophore-mediated diagnosis of fungal infections

Ao.Univ.-Prof.Mag.Dr.rer.nat.Hubertus Haas (MUI)

Hubertus Haas is working at the Biocenter. He is a basic scientist involved in fungal diseases and in particular is interested in the iron homeostasis of the fungus and the role of iron as a virulence factor. One of his targets is siderophores which allow the fungus to acquire iron in hostile environments.



HOROS retreat in Obergurgl with PhD students from Univ. of Copenhagen and lecturers from Copenhagen, Erlangen, Helsinki, Oslo and Oxford, March 2016



HOROS work group

Establishment of a human lung tissue model to study fungal infections

Univ.-Prof.Dr.med.Cornelia Lass-Flörl (MUI)
Cornelia Lass-Flörl directs the Division of Hygiene and Medical Microbiology. Her research focuses on fungal infections with a special emphasis on the diagnosis, prevention and therapy of invasive infections and antifungal drug resistance.

Influence of donor and recipient age on the outcome in SOT (Solid Organ Transplantation)

Univ.-Prof.Dr.rer.nat. Katja Kotsch
Katja Kotsch was working at the Dept. of Visceral, Transplantation- and Thoracic Surgery and has recently taken up a professorship in Berlin. Her PhD student moved with her and will soon finish her PhD in Berlin, as the university has recognized all her achievements under the wings of HOROS.

Mechanisms for the specific acquisition of complement regulatory proteins by HCV (Hepatitis C Viruses)

Ao.Univ.-Prof.Dr.rer.nat. Heribert Stoiber (MUI):
Heribert Stoiber is specialized in medical microbiology and virology; he is deputy head of the Division for Virology. His research focuses on the interplay of viruses with the complement system, in particular with evasion mechanisms that viruses apply in order to circumvent the lytic action of the human complement system.

Role of NRAMP-1 (Natural resistance-associated macrophage protein 1) in the control of host resistance against infection with intracellular bacteria

Univ.-Prof.Dr.med. Günter Weiss (MUI)
Günter Weiss is professor of clinical immunology and infectious diseases at the Dept. of Internal Medicine. His research interest focuses on disorders of iron homeostasis and host-pathogen interaction with a special emphasis on regulatory interactions between iron homeostasis, natural resistance genes and immune function in various infections. He is the coordinator of CIIT at MUI.



Horos or Horus, Egyptian god of protection from disease, patron for doctoral programme of excellence HOROS

Selected Publications

- <https://www.i-med.ac.at/mypoint/news/678834.html>
- <https://www.i-med.ac.at/mypoint/news/685914.html>
- <https://www.i-med.ac.at/mypoint/thema/689516.html>
- <https://www.i-med.ac.at/mypoint/news/698948.html>

Selected Funding

- HOROS - doctoral programme of excellence, FWF DK W1253-B24, € 2.380.000

Collaborations

- Peter Zipfel, Univ. Jena, Germany
- Peter Garred, Univ. Copenhagen, Denmark
- David Denning, Univ. Manchester, Great Britain
- Beate Kehrel, Univ. Münster, Germany
- Jürgen Löffler, Univ. Würzburg, Germany
- Axel Brakhage, Univ. Jena, Germany
- Ioav Cabantchik, Univ. Jerusalem, Israel
- Ferric Fang, Univ. Washington/Seattle, USA
- Andreas Radbruch, DRFZ Berlin, Germany
- Giuseppe del Giudice, Novartis, Siena
- Stefan G. Tullius, Univ. Boston, USA
- Ondrej Viklicky, Univ. Prague, Czech Republic
- Thomas Pietschmann, Univ. Hannover, Germany
- Alexandra Trkola, Univ. Zurich, Switzerland

Signal Processing in Neurons – DK SPIN



Speaker:
Univ.-Prof. Dr.
Francesco Ferraguti

Contact:
Department of Pharmacology
Peter Mayr Str. 1a
6020 Innsbruck

SPIN@i-med.ac.at
Phone: +43 512/9003-71204
www.neurospin.at

What is SPIN?

SPIN is a joint doctoral program at the Medical University of Innsbruck (MUI) and the University of Innsbruck (LFUI). It was established in September 2007 with the support of the Austrian Science Fund (FWF) and offers interdisciplinary postgraduate training in translational Neuroscience for excellent Austrian and international students. It combines the expertise in Neurosciences across departments, making it currently the only FWF-funded doctoral college in Austria with an exclusive focus on Neuroscience.

Research

SPIN focuses on inter- and intraneuronal signalling mechanisms in both health and disease and concentrates on the role that fundamental molecules involved in neural signalling may have in neurodegenerative diseases, neuroinflammation and plasticity. The network thus strongly focuses on the development and characterisation of novel cellular and animal models. In order to investigate the neural mechanisms by which the brain produces adaptive and maladaptive behaviours, the SPIN network uses an integrative, crossover approach. SPIN steers towards stronger interactions between students and faculty members in or-

der to reach a new level of understanding of the fundamental integrative processes that govern the signalling within and between nerve cells under normal and pathological conditions. To that end, the network has initiated a variety of integrated PhD projects.

The SPIN program has identified three broader areas of research:

- molecular/cellular neuroscience
- neuronal physiology and pathophysiology
- behavioural neuroscience

Training in SPIN

The field of Neuroscience has changed considerably in the past few years, increasing the demand for highly-trained Neuroscientists. The main goal of SPIN is to equip its students with the practical and theoretical knowledge they need in order to contribute substantially to future scientific advances in Neuroscience. In order to obtain a PhD at our institution, students must carry out an experimental study and complete the courses in the PhD curriculum. SPIN students work under the tutelage of a supervising professor and a board of advisors, the “Thesis Steering Committee” (TSC). In addition to the supervisor, the TSC consists of two experienced researchers that guide the student. Throughout the process of

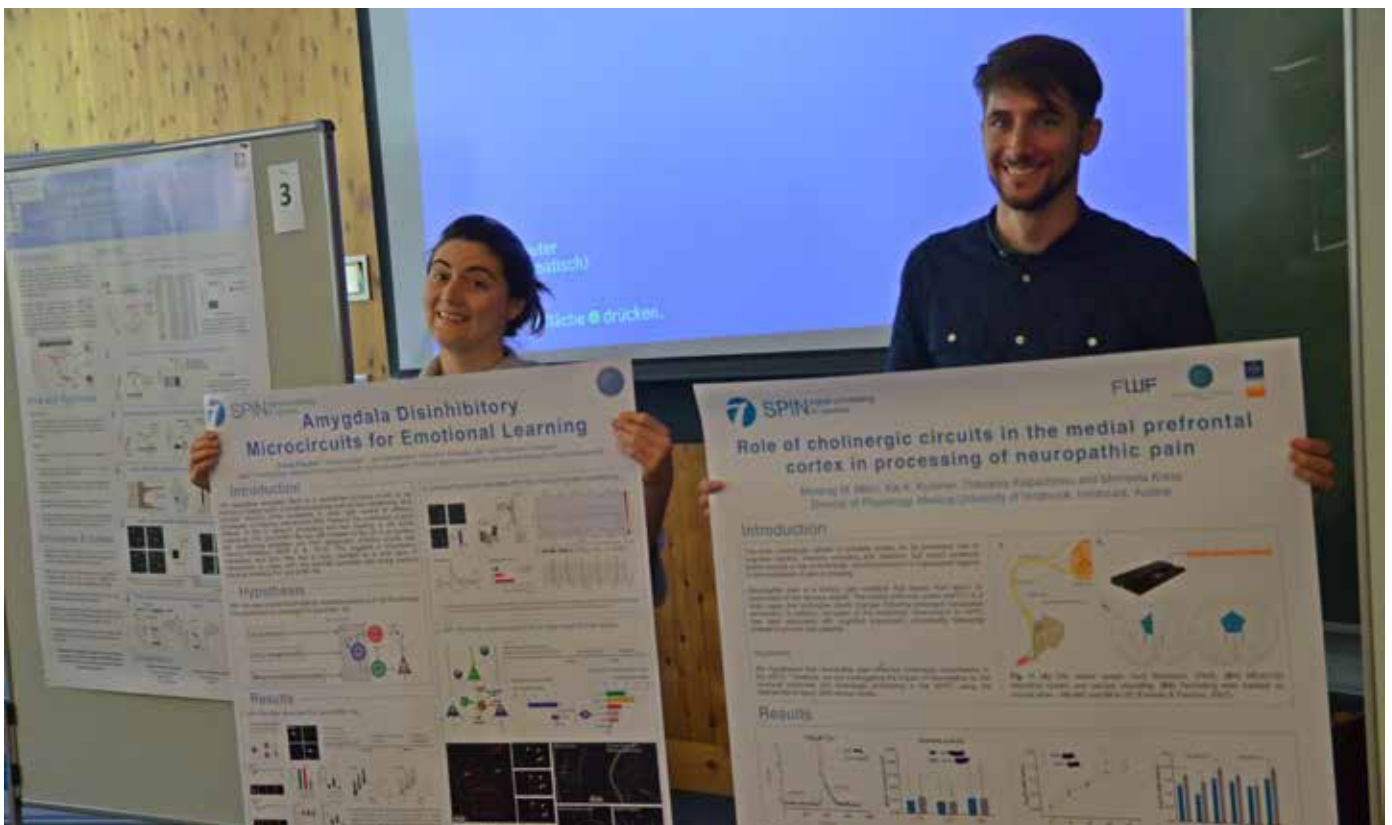

preparing the thesis, the steering committee evaluates and supervises the progress of the PhD work in regular and structured meetings with the student.

Spin Activities

The SPIN network meets on a bi-weekly basis for the progress reports. At the progress reports, two students present the progress of their research to other students and faculty members and the members have the opportunity to discuss various matters. SPIN students also benefit from the many extra activities that the network offers. These include a lecture series, to which students get to invite senior scientists of their choice, as well as career development activities and annual retreats.

SPIN in numbers

PIs: 9
Departments: 8
Current students: 18 (10 female, 8 male)
Alumni: 29 (17 female, 12 male)
Nationalities: 15
Student Publications: 97

Funding

FWF: 6.904619,50 € (until the end of 2019)
MUI: 2.613743,50 € (until the end of 2016)

SPIN Faculty

Univ.-Prof. Dr. Christine Bandtlow
Division of Neurobiochemistry

Univ.-Prof. Dr. Georg Dechant
Institute for Neuroscience

Univ.-Prof. Dr. Francesco Ferraguti
Department of Pharmacology

Univ.-Prof. Dr. Frank Edenhofer
Department of Genomics, Stem Cell Biology & Regenerative Medicine (LFUI)

Univ.-Prof. Dr. med. Michaela Kress
Department of Physiology and Biomedical Physics

ao. Univ.-Prof. Dr. Christoph Schwarzer
Department of Pharmacology

ao. Univ.-Prof. Dr. Nicolas Singewald
Department of Pharmacology and Toxicology (LFUI)



SPIN Faculty Members and students

ao. Univ.-Prof. Dr. Nadia Stefanova
Department of Neurology, Division of Neurobiology

ao. Univ.-Prof. Dr. med. Gerald Zernig
Experimental Psychiatry Unit

Associated Members

Univ. Prof. Dr. med. Lars Klimaschewski
Department of Anatomy, Histology and Embryology

Univ. Prof. Dr. Hans-Günther Knaus
Department of Molecular Pharmacology

Assoz. Prof. Dr. Alexandra Koschak
Department of Pharmacology and Toxicology (LFUI)

Ao. Univ.-Prof. Dr. Markus Reindl
Department of Neurology

Univ.-Prof. Dr. Alois Saria
Experimental Psychiatry Unit

Univ.-Prof. Dr. Gregor Wenning
Department of Neurology, Division of Neurobiology

SFB-F44 – Cell Signaling in Chronic CNS Disorders



Coordinator :
Univ.-Prof. Dr. Jörg Striessnig (LFU)

Contact:
Department of Pharmacology and Toxicology - Institute of Pharmacy, Innrain 80-82, Innsbruck University of Innsbruck (LFU)

sfb-f44@uibk.ac.at
Phone: +43 512 507 58801
Fax: +43 512 507 58899
www.uibk.ac.at/pharmazie/pharmakologie/sfb-f44/

General Facts

As outlined in previous reports, the major research goal of the SFB-F44 is to improve our understanding of molecular mechanisms relevant for normal brain function and their dysfunction in human central nervous system (CNS) disorders. A better understanding of disease-relevant processes is particularly important in neuropsychiatric and neurodegenerative disorders, which would ultimately lead to improvement of currently drug therapies, which are often unsatisfactory. The development of novel and improved therapeutic strategies requires the identification of innovative targets for therapeutic intervention. Therefore, competent laboratories at the two Innsbruck universities joined their complementary expertise to comprehensively study signalling pathways that bear such potential. The major research focus is on L-type calcium channels (LTCCs) and epigenetic modulators, including histone deacetylases (HDACs) and non-coding RNAs. These pathways participate in the aetiology of several neurological and neuropsychiatric disorders. Moreover, recent findings from our consortium show that they can be (patho-) physiologically

linked. Strong local expertise is bundled to study calcium-mediated, epigenetic and non-coding RNA (ncRNA)-mediated regulatory mechanisms to disclose the role of these pathways for the pathophysiology of Parkinsonian disorders (Parkinson's disease, Multiple System Atrophy), Alzheimer's disease and abnormal fear and anxiety and more recently autism spectrum disorders.

Members and Projects MUI

Gerald Obermair, Bernhard E. Flucher, Division of Physiology

Importance of Intra- and Extracellular Cav1.3 Modulators for Synapse Stability in Normal and Diseased Striatal Medium Spiny Neurons

In brain dendritic spines are small postsynaptic membrane protrusions on neuronal dendrites involved in excitatory synaptic transmission and synaptic plasticity. Neuronal L-type calcium channels are located in dendritic spines and contribute to the local concentration of the ubiquitous second messenger calcium. Thereby, calcium channels integrate synaptic signals, effect changes in spine morphology and the synaptic structure and contribute to basic neuronal functions including learning and memory formation. Neurological diseases are often accompanied by synaptic adaptations including altered form and function of dendritic spines. For example, a specific loss of dendritic spines of striatal neurons has previously been shown to be involved in the pathology of Parkinson's disease (PD). Interestingly, a loss of dendritic spines in the striatum may also underlie the development of L-DOPA-induced dyskinesia, the major debilitating side effect of the common treatment for PD. In publications during the first SFB funding period, we identified a specific role of a specific L-type calcium channel and its interaction with postsynaptic proteins in regulating the stability of dendritic spines. Building on this important result, we now test in the ongoing project whether and how this proposed mechanism contributes to the aetiology of PD and other neuronal diseases, such as autism. We are employing high- and super-resolution fluorescence microscopy and state-of-the-art electrophysiology. Our results will contribute to the understanding of synaptic adaptations during neurological disorders and probe the therapeutic potential of targeting the identified synaptic mechanisms.

Nadia Stefanova, Gregor Wenning, Department of Neurology

Alpha-synuclein – a Pathogenic Trigger and Interventional Target in Multiple System Atrophy
Multiple system atrophy (MSA) is a distinctive neurodegenerative disorder character-

ised by oligodendroglial cytoplasmic inclusions of fibrillary α -synuclein (α -syn) and associated with progressive multisystem neurodegeneration. Our group will provide detailed characterisation of the functional phenotype of a transgenic mouse model with targeted overexpression of α -syn in oligodendrocytes as an important readout for preclinical drug screening for MSA. To identify underlying pathogenic mechanisms and candidate targets for future therapies, we will focus on the putative bilateral interactions between epigenetic factors and α -syn aggregation and propagation in MSA models. The outcomes are likely to critically enhance our insights into the pathogenesis and progression of MSA. The results will have immediate relevance for interventional target discovery which in turn will promote future clinical trial activities in MSA patients.

Alexander Hüttenhofer, Division for Genomics and RNomics

Identification of Regulatory ncRNAs in Chronic CNS Disorders

This project aims to identify regulatory ncRNAs involved in neuronal development and chronic CNS disorders. Using special probes and techniques recently developed in this lab, ncRNAs that are regulated in disease and may therefore contribute to signalling pathways involved in neurodegeneration will be identified and characterised. Existing expertise will also be used to probe for regulatory ncRNAs participating in L-type calcium channel-mediated plasticity and nuclear signalling in various neurons.

Georg Dechant, Galina Apostolova, Institute for Neuroscience

Function of Special AT-rich Sequence-Binding Protein 2 (Satb2) in Aging and Neuronal Pathophysiology

Complex behaviours such as learning and memory depend on changes in gene expression and subsequent long-lasting adaptations in synaptic strength and structure. Current research interests of this group are focused on the mechanisms of neuronal plasticity, with special emphasis on the role of chromatin conformation regulation in adaptive gene transcription. A classic example of neuronal plasticity is the switch from noradrenergic to cholinergic neurotransmission, which occurs in differentiated postganglionic sympathetic neurons under the influence of target-derived signals. We identified the genome organiser Special AT-rich sequence binding protein 2 (Satb2) as an acutely up-regulated target gene of neurokinin/p38 MAPK signalling in sympathetic neurons undergoing trans-differentiation. Gain-and loss-of-function studies of this group revealed that Satb2 is both necessary

and sufficient to trigger the sympathetic neurotransmitter switch. Therefore, modulation of *Satb2* and consequently chromatin architecture by neurotrophic factors might serve as a novel pathway involved in the long-term adaptive processes underlying higher brain functions. In support of this hypothesis, a recent publication in our laboratory showed that *Satb2* is induced by plasticity-mediating extracellular signals such as BDNF or calcium-influx through L-type voltage-gated calcium channels in CNS neurons. The analysis of a conditional mutant lacking *Satb2* in the adult forebrain (generated by our group), demonstrated that *Satb2* is required for synaptic plasticity and long-term memory formation. In addition, we found that *Satb2* interacts with genome organising proteins of the inner nuclear membrane and regulates the geometry of neuronal nuclei in the hippocampus in vivo. Therefore *Satb2*-containing DNA-protein complex may determine both the nuclear shape and chromosomal conformations in neurons downstream of L-VGCC and BDNF signalling, thereby integrating plasticity-mediating extracellular signals into changes in the transcriptome. Future goals are to provide evidence that *Satb2*-dependent rearrangements of the nuclear architecture and/or changes in the epigenetic profiles are necessary for higher cognitive functions and that dysfunction of these mechanisms leads to learning and memory deficits. Another aim is to study whether cognitive deficits inherent to normal ageing and neuropsychiatric diseases are caused by alterations in *Satb2* expression or function.

Francesco Ferraguti, Institute of Pharmacology: Dopamine Regulation of Amygdala Inhibitory Circuits: Relevance for Pathological Fear Structures

Parkinson's disease (PD) is classically considered as a movement disorder resulting from the loss of dopaminergic (DAergic) neurons. However, a number of non-motor symptoms, including pathological fear and anxiety, predate the emergence of motor impairment. PD could then be seen as a multi-dimensional disease. Dopamine exerts a pivotal role in the regulation of fear responses most likely by affecting GABAergic transmission within the amygdaloid complex. We postulate that pathological fear in early PD results from altered associative plasticity in the basolateral amygdala (BLA) mostly dependent on the reduced function of DA on specific local interneurons. In addition, enhanced phasic DAergic transmission during fear extinction training may facilitate extinction learning and the concurrent plasticity. These hypotheses will be experimen-

tally addressed by means of a multidisciplinary approach combining optogenetics, viral monotransynaptic tracing and novel ultra-structural techniques. A mouse model for non-motor symptoms of early PD, lacking motor impairments, will also be established and characterised. Therefore, this project will complement other investigations within this SFB on aberrant signalling mechanisms leading to selective neurodegeneration (e.g. PD), altered neural plasticity and abnormal fear memory processing.

Members University of Innsbruck (LFU) Nicolas Singewald, Department of Pharmacology and Toxicology

Epigenetic Mechanisms in Aberrant Memory Regulation

Effective long-term treatment for fear and anxiety-related disorders is a continuing challenge. One emerging treatment strategy is to combine exposure-based cognitive behavioural therapy (CBT) with cognitive enhancers. Key results from the first SFB funding period (FP) support the utility of this approach for long-term fear inhibition. Specifically, we provide evidence that histone deacetylase (HDAC) inhibitors and facilitating dopaminergic signalling act as cognitive enhancing strategies to rescue aberrant fear extinction consolidation in S1 (129S1/SvlmJ) mice. Recently published evidence does indeed show that non-coding RNAs, including microRNAs (miRNAs), additional promising targets to exploit novel pro-cognitive properties supporting extinction memory formation. Building on results obtained in the 1st FP, we now aim to elucidate the how and where in the brain HDAC inhibition, enhancement of dopaminergic signalling, interference with non-coding RNAs- or Cav1.3 mediated-signalling can augment fear extinction to form a persistent and context-independent fear inhibitory memory. In addition, we aim to improve the tolerability of exposure-based therapy by combining the therapeutic actions of non-sedative anxiolytic drugs which do not impair extinction learning and appropriate cognitive enhancers. Finally, this project started to identify potential epigenetic biomarkers in blood cells that can be associated with the sensitivity to and the extent of the therapeutic effect of exposure therapy in anxiety disorder patients. Revealing mechanisms via which the rescue of impaired fear extinction can be achieved in a better tolerated, persistent and context-independent manner is expected to foster the rational development of novel cognitive enhancers which may be used as augmenting CBT adjuncts to treat anxiety disorders more effectively.

Jörg Striessnig, Department of Pharmacology and Toxicology
Role of Cav1.2 and Cav1.3 Calcium-Channels for Parkinson's Disease and Neuropsychiatric Disorders

L-type calcium channels (LTCCs) have recently emerged as novel drug targets for the treatment of Parkinson's disease (PD) with already licensed or new channel blockers. The concentrations of available drugs required for effective block, the LTCC channel isoforms involved in PD pathophysiology and the mechanisms of neuroprotection are still not known. This group recently also published evidence that human mutations causing an increase in the activity of brain LTCCs, in particular the so-called Cav1.3 subtype, because neuropsychiatric diseases such as autism spectrum disorders (ASD). This suggests a pathogenic and thus also potentially therapeutic role of brain LTCCs beyond PD. New tools and assays developed to determine if LTCCs in the brain are blocked as effectively as Cav1.2 channels in the cardiovascular system. This allows predictions if already licensed drugs can be used for neuroprotection in PD or the therapy of selected ASD patients with Cav1.3 mutations. Meanwhile, suitable mouse models were established that will allow studying the functional consequences of human ASD mutations in different tissues, in particular the brain. Finally, we ask the question if knockout of Cav1.3 channels or chronic inhibition of these channels leads to compensatory upregulation of other ion channels that could counteract their pharmacological action. These highly translational questions will be addressed in collaboration with other members of the consortium. Our work has immediate relevance for the better understanding of calcium-dependent human disease mechanisms and ongoing drug discovery in industry.

Members from other Universities

Birgit Liss, University of Ulm

Ludwig Aigner, Paracelsus Medical University Salzburg

Associated Members

Alexandra Koschak, Department of Pharmacology and Toxicology, University of Innsbruck
Klaus Liedl, Institute of General, Inorganic and Theoretical Chemistry, University of Innsbruck;

Alexandra Lusser, Division of Molecular Biology, Medical University Innsbruck;

Eduard Stefan, Institute of Biochemistry, University of Innsbruck;

Publications

See: <https://www.uibk.ac.at/pharmazie/pharmakologie/sfb-f44/publications/>



Core Facilities

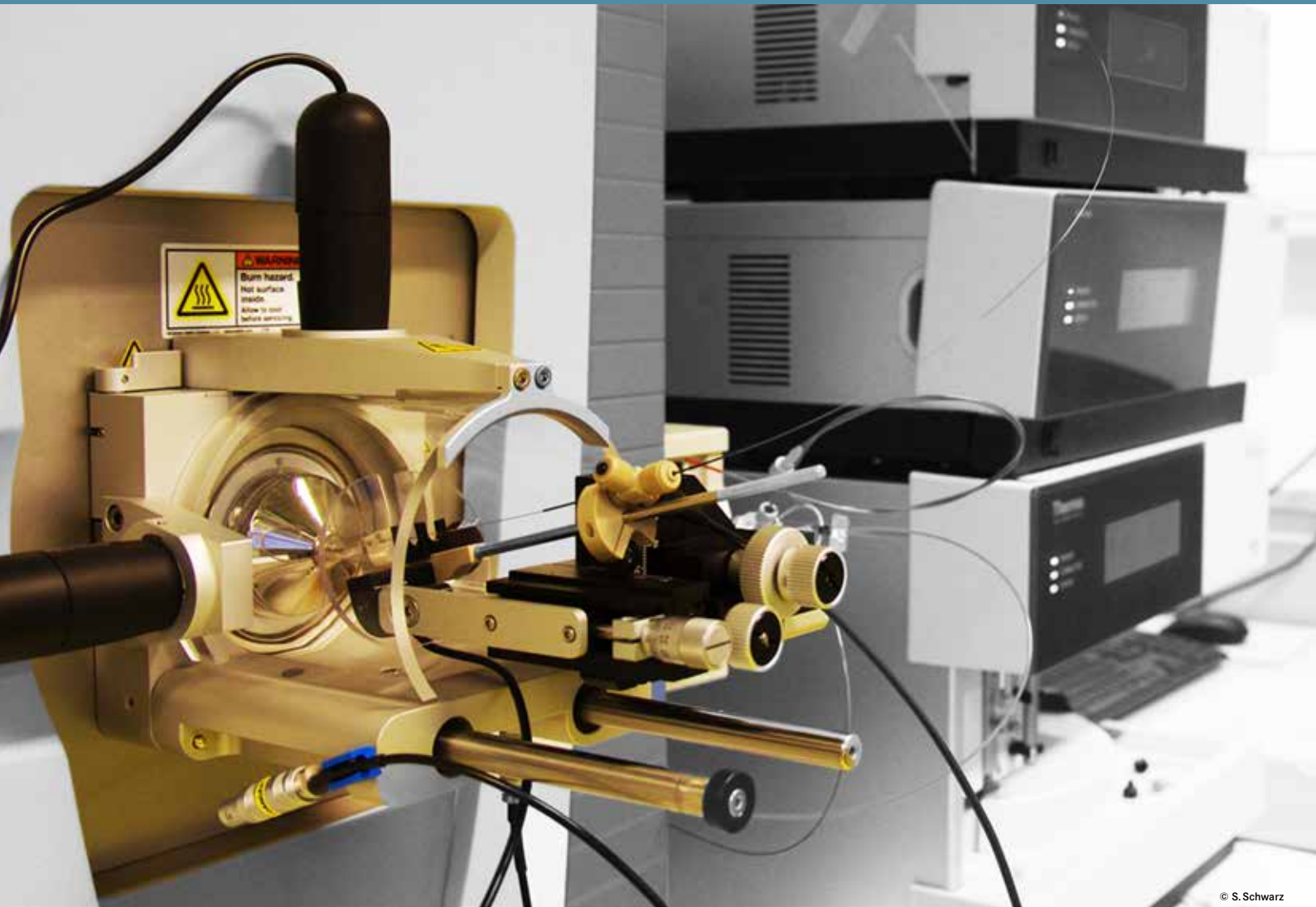

© S. Schwarz



© S. Schwarz

Core Facilities

Protein Micro Analysis

The protein facility established at Innsbruck Medical University is dedicated to provide investigators with equipment, expertise and custom services for the detection, characterization and quantification of proteins and peptides on a recharge basis. The facility maintains a suite of state of the art instrumentation including different mass spectrometers (e.g. QExactive HF and LTQ Orbitrap XL from ThermoScientific) coupled to nano-LC gradient systems and capillary electrophoresis. Also trace element analysis is provided using a Solaar M6 Dual Zeeman spectrometer (ThermoScientific). Services include comprehensive protein identification of simple and complex protein digests, quantitative proteomics using isotope labeling strategies (e.g., SILAC, iTRAQ, TMT), localization and quantification of post-translational modifications (phosphorylation, acetylation, methylation, etc.).

Contact:

ao. Univ.-Prof. Dr. Herbert Lindner
Herbert.Lindner@i-med.ac.at
Phone: +43 512 9003 70310

Metabolomics

The mission of the Core Facility Metabolomics is to serve as an enabling resource for research and development programs. We aim to provide expertise and state-of-the-art technologies for the qualitative and quantitative analysis of small bioorganic molecules. Common targets are drugs, pharmaceuticals, endogenous compounds, and metabolites thereof included in all kinds of biological samples (e.g. biofluids, cells, tissues). The analytical method of choice is mass spectrometry (MS). Usually MS is hyphenated to chromatographic Methods (liquid chromatography or gas chromatography).

Contact:

o. Univ.-Prof. Dr. Richard Scheithauer
Richard.Scheithauer@i-med.ac.at
Phone: +43 512 9003 70601
Assoz. Prof. Dr. Herbert Oberacher
Herbert.Oberacher@i-med.ac.at
Phone: +43 512 9003 70639

Sequencing and Genotyping

The Sequencing & Genotyping Core Facility was founded in 2004 and focuses on high throughput DNA sample processing, SNP genotyping, real-time PCR, Sanger sequencing and analysis of mitochondrial DNA using both Sanger and next-generation sequencing.

Contact:

Univ.-Prof. Dr. Florian Kronenberg
Florian.Kronenberg@i-med.ac.at
Phone: +43 512 9003 70560
Dr. Stefan Coassin
Stefan.Coassin@i-med.ac.at
Phone: +43 512 9003 70576

Biooptics/Light microscopy

The Biooptics/microscopy facility of MUI, located at the new CCB (room 01.370), aims at providing university wide access to advanced equipment, such as automated widefield fluorescence microscopes, confocal microscopes (LSM and spinning disk) and a gSTED superresolution microscope (Nobelprize 2014 to Hell and colleagues) which is offered in cooperation with the LFU Innsbruck, training, education and expertise in light microscopy. The facility currently offers assisted access to research microscopes and image processing software. Moreover a number of courses are offered within the different PhD training programmes at MUI.

Contact:

PD Dr. Martin Offterdinger
Martin.Offterdinger@i-med.ac.at
Phone: +43 512 9003 70284

FACS Sort Core Facility

The Innsbruck Flow Cytometry Unit provides access to state of the art analytical and sorting flow cytometry instrumentation and technology and offers professional cell sorting service to the research community in Innsbruck. The facility also provides training in flow cytometer use and data analysis for students, researchers and staff, and supports investigators in experimental design of flow cytometric applications. In addition, educational courses on recent advancements in flow cytometry are regularly organized.

Contact:

PD Mag. Dr. Sieghart Sopper
Sieghart.Sopper@i-med.ac.at
Phone: +43 512 504 26332

Deep Sequencing

The Genome-Seq Core is an integral part of the Innsbruck Medical University Biocenter, providing large-scale sequencing to the local and international research community. We aim to provide the highest level of service, confidentiality, and support, working with the researchers to reach their goals.

Contact:

Univ.-Prof. Dr. Alexander Huettenhofer
Alexander.Huettenhofer@i-med.ac.at
Phone: +43 512 9003 70250
Anne-Margrethe Krogsdam Christensen,
MSc PhD
Anne.Krogsdam@i-med.ac.at

Micro CT

High-resolution cross-sectional imaging examinations and non-destructive 2D and 3D structural analyses in μm scale based on x-rays. Support and implementation of advanced image analysis and image processing and visualization methods with high-performance programmes, as well as Finite Element (FE) analyses. Implementa-

tion of 3D model prints of the objects and substances examined under high resolution down to μm scale. Where applicable information is passed on to competent partners.

Contact:

PD Dr. Wolfgang Recheis
Wolfgang.Recheis@i-med.ac.at
Phone: +43 512 504 24216

High Resolution Ultrasound

With the beginning of 2016 a high-resolution ultrasound device (VisualSonics Vevo 1100) will be on hand at the Cardiac Surgery Research Laboratory. The new ultrasound device facilitates non-invasive, functional, and image-based analyses of different organ systems in mouse, rat, and (with limitations) rabbit. The technology allows for a time-resolved analysis in individual animals, which results in increased data quality with a simultaneous reduction in the number of experimental animals. The system facilitates high resolution, time-resolved, and functional in vivo imaging of moving structures e.g. heart.

Contact:

PD Dr. Johannes Holfeld
Johannes.Holfeld@i-med.ac.at
Phone: +43 512 504 80800

Neuroimaging Research

The main modality of this CF is the BMFWF-funded 3 Tesla-MRI-system, which establishes a core facility for MR-based neuroimaging research at the MUI. The 3T MRI started work exclusively for research use in 2012. The CF-NIR is centrally administered by the Head of the Department of Neuroradiology, who leads an interdisciplinary Steering Board. The technical equipment is supported by one physicist and an assistant radiographer. The Team "Neuroradiology" provides support to all associated scientists in technical and post-processing questions. Furthermore, the core facility develops and introduces new MR sequences and technical equipment. Above all, the Neuroimaging platform offers opportunities to bring different groups together and to transfer knowledge, and it provides a setting for communication and cooperation in neuroimaging. A recently acquired BMFWF grand (Neuroimage WING) is an excellent example of this interdisciplinary and inter-university orientation.

Contact:

Univ.-Prof.ⁱⁿ Dr.ⁱⁿ Elke Ruth Gizewski MHBA
Elke.Gizewski@i-med.ac.at
Phone: +43 512 504 24202

Imprint

Research Report 2016 of the Medical University of Innsbruck



ClimatePartner^o
climate neutral

Print | ID 10170-1707-4283

A publication of the Medical University of Innsbruck; editors and layout: Pamela Schech, Johannes Ghetta, BSc, Damla Celikel; Servicecenter Forschung, Schöpfstraße 45, A-6020 Innsbruck
Language editors: a. Univ.-Prof. Dr. Paul Debbage, Mag. Gudrun Thurner, PhD, Mary Creighton, Dr. Agnes Balog
Images: Medical University of Innsbruck, Florian Lechner, Christof Lackner; ao.Univ.-Prof. Dr. Siegfried Schwarz
Pictures of buildings: MUI/Christof Lackner, MUI/Franz Oss, Siegfried Schwarz, MUI/Kinderklinik, MUI/Romed Hörmann
Cover layout: Servicecenter Forschung; cover photos: MUI/Lechner, MUI/Dr. Martin Hermann & ao.Univ.-Prof. Dr. Cornelia Speth, MUI/Lackner
Printed by: Onlineprinters GmbH, certificated by FSC and PEFC; produced climate neutrally; electronic version: KULTIG Werbeagentur
The head of the research unit is responsible for the content and pictures of the relevant contribution. Typing and printing errors reserved.





